



Xe-50M & Xe-70M Fixed Speed Control Systems

Technician's Guide

CONTENTS

TOPIC	PAGE
Xe-50M Controller Introduction	1
Controller I/O Summary	1
Controller Interface / Operation	2
Interface Layout	2
Icons/Display Layout	2
Operation and Configuration Menu Charts	3
Timer Descriptions	4
Alarm and Shutdown Events	5
Alarm (Warning) Codes	5
Shutdown (Trip) Codes	6
Wiring Schematics	6
<hr/>	
Xe-70m Controller Introduction	9
Component Review	10
Controller I/O Summary	24
Controller Interface / Operation	25
Interface Layout	26
Menu Navigation Map	27
Icons/Display Layout	28
Home Folder	36
System Overview	36
Counters	38
Analog Inputs & Compressor Information	39
Operator Settings Folder	41
Operator Settings	41
Operator Options	44
Sensor Calibration	48
Events Folder	50
Event History	50
Warning Events List	52
Trip Events List	56

TOPIC	PAGE
Start Inhibit List	58
Trip History	59
Maintenance Folder	60
Filter Status	60
Maintenance Configuration	61
General Settings	62
Language and Units Selection	62
Time & Date Settings	63
Backlight Settings	64
Serial Port Address Settings	65
Ethernet Settings (ECO Module Only)	66
Integral Sequencing Folder	67
Setup	69
Tuning	70
Priority	71
Rotation	72
Status Folder	73
Analog Inputs	73
Compressor Data	74
Digital Inputs	75
Digital Outputs	76
Analog Outputs	78
CT Inputs	78
Factory Settings Folder	79
Password	79
Factory Setpoint	80
Software Version	84
Connection to the MODBUS Network	85
RS-485 Network	85
MODBUS Address Selection	86
MODBUS Master Settings	87
Supplemental Material	88

XE-50M CONTROLLER INTRODUCTION

The Xe-50M is standard on 5-15HP fixed speed units and is powered through a stepped down 24 Vac power supply. A stepped down voltage of 110 Vac is fed and switched by internal relays to control the opening and closing of the contactors and solenoid valves. The exception to this is R1 output, which provides a 24 Vac output. Discharge pressure is monitored by a 4-20mA transducer (4APT). The pressure transducers are NOT interchangeable with the pressure transducers on the Xe-70M/90M/145M. Aired discharge temperature is monitored by a PTC type RTD (2ATT), where $0^{\circ}\text{C} = 100\Omega$. The resistance value changes by 0.385Ω per degree Celsius.

Xe-50M Controller I/O Summary

Analog Inputs

- X02-A1 Package Discharge Pressure Transducer 4APT
- X02-A2 Aired Discharge Temperature Thermistor 2ATT

Digital Inputs

- X03-C2 Main and Blower Motor Overload QF4/FA1
- X03-C3 Remote Start/Stop
- X03-C4 Dryer Temperature Switch Alarm
- X03-C5 Dryer Pressure Switch
- X03-C6 Not used (0;Anc) or
Remote load/unload (4:rLu) or
Sep Element Delta P (1:Anc)
- X04-RC1 E-Stop (24 Vac Only)

Digital Outputs

- X04-R1 Load/Unload Solenoid/Relay (24Vac)
- X04-R2 Main Contactor Coil (KM1)
Delta Contactor Coil (KM2)
Blower Contactor Coil (KM4)
Electronic Drain Valve (EDV)
- X04-R3 Star Contactor Coil (KM3)

X04-R4 Dryer Run Output (optional)
X06 RS485 Communication

Xe-50M Controller Interface and Operation

The standard user interface configuration of the controller consists of the membrane and the LCD display. The membrane consists of three command keys (Start, Stop, and Reset), two navigation keys (Up and Down), and an Edit mode selection key (Enter). These keys, in conjunction with the display, make up the user interface to the compressor.

Xe-50M Interface Layout

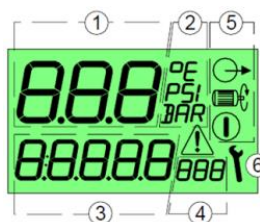
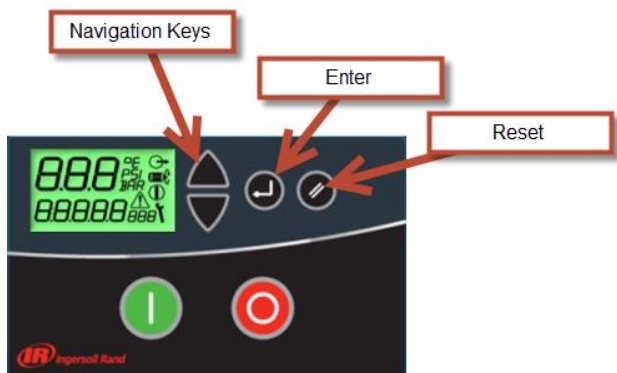

- 1: Main Display Value
- 2: Main Display Value Units
- 3: User Menu Item Display Value
- 4: User Menu Item Display Units
- 5: Status Symbols Started, Running, Loaded
- 6: Service/Fault Symbols Service, Fault: Alarm/Warning/Trip

① Started, ② Running, ③ Loaded
⚠ Service, ⚠ Fault: Warning/Trip

To enter the following menus, press the Up and Down arrows simultaneously and enter the corresponding access code using the Up and Down arrows:

E06 Operational Menu (Access Code 0009)			
Item	Description	Default	
		Unit	Value
1.Pu	Upper Pressure Setpoint	Bar	7.2
1.PL	Lower Pressure Setpoint	Bar	6.5
1.Sd	Motor Star/Delta Time	Sec	5
1.P-	Pressure Display Unit	Bar	Bar
1.t-	Temperature Display Units	°C	°C
1.LS	Load Source	-	0=local
1.SS	Start Source	-	0=local

E06 Configuration Menu (Access Code 0121)			
Item	Description	Default	
		Unit	Value
2.Sh	Service Interval Hours	Hours	2000
2.rt	Run-on Time	Sec	360
2.bt	Blowdown Time	Sec	10
2.St	Stop Time	Sec	5
2.Ad	RS485 Network Address	-	1
2.PA	High Pressure Alarm Level	Bar	7.3
2.PF	High Pressure Trip Level	Bar	7.5
2.tA	High Temp Alarm Level	°C	105
2.tF	High Temp Trip Level	°C	109
2.d2	Digital Input 'C2' Config	-	3:Enc
2.d3	Digital Input 'C3' Config	-	0:Ano
2.d4	Digital Input 'C4' Config	-	0:Ano
2.d5	Digital Input 'C5' Config	-	0:Ano
2.d6	Digital Input 'C6' Config	-	0:Ano
2.Po	Pressure Sensor 'Offset' Cal	Bar	0
2.Pr	Pressure Sensor 'Range' Cal	Bar	16
2.tL	Low Temp Load Inhibit	°C	2
2.tr	Low Temp Run Inhibit	°C	2

Service Due Countdown Timer

If the service due countdown timer reaches 0 (Zero) hours the Service and Alarm symbols will flash and the service Alarm (Warning) code will be displayed. The Alarm code can be reset but the service symbol will remain on the display until the service due timer is reset; the service hours will continue to decrement in negative hours. The service countdown timer can be reset, using the menu routine, when the required service has been carried out. Set to any value greater than 0 (Zero) hours before reset.

Blowdown Timer

When the main motor stops the compressor will allow a period of blowdown (the Blowdown Time) before a motor start can be re-initiated. A motor re-start is inhibited during this time period. This time is intended to allow internal pressure (or sump pressure) to be vented before a motor start sequence is permitted. Set to 0 (zero) seconds if not required.

Stop Time

When the Stop button is pressed the compressor will unload and the main motor will continue to run for the set Stop Time. This time is intended to allow internal pressure (or sump pressure) to reduce before the compression element is stopped; preventing potential oil blow-back through the compression element and air filter. The stop time is initiated from the moment the compressor is unloaded. If the compressor has been offload for a period of time prior to a stop command the time is automatically reduced accordingly. If the compressor is stopped after the compressor has been running offload for the stop time, or longer, the compressor is stopped immediately; no stop time is applied. Set to 0 (zero) seconds if not required.

Xe-50M Fault Codes

If a Fault condition occurs the Fault triangle symbol will switch ON steady (Warning) or flash (Trip). The user menu display item will show a 'Fault Code' dependent on the fault.

Fault codes are separated into two categories:

Alarm (Warning) Codes - A: Warning symbol illuminated on steady, the compressor will continue to operate.

Code	Description
A:0060	High Sep Element Delta P (If installed)
A:2040	Freeze Warning (TAS only) (DI - C4)
A:2050	Dryer High Pressure (TAS only) (DI - C5)
A:2118	High pressure: alarm limit exceeded
A:2128	High Temperature: alarm limit exceeded
A:2816	Power Failure Detected
A:3123	Run Inhibited - Temperature is below set low temperature run inhibit limit (will self-reset when temperature increase above the set temperature limit; cannot be manually reset)
A:3129	Airend Discharge Temperature is above than 103°C
A:3423	Load Inhibited - temperature is below set low temperature load inhibit limit (will self-reset when temperature increases above the set temperature limit; cannot be manually reset)
A:4804	Service Due - service interval hours counter has reduced to zero

Shutdown (Trip) Codes - E: Trip symbol will flash, the compressor will stop.

Code	Description
E:0010	Emergency Stop – 24 Vac in not detected on terminal R1C
E:0020	Main or blower Motor Overload DI - C2
E:0030	Remote Start Failure DI - C3
E:0040	High Discharge Pressure DI - C4
E:0050	N/A DI - C5
E:0060	N/A DI - C6
E:0115	Pressure Sensor Fault: 4-20mA signal out-of-range (<3.8mA or >20.8mA)
E:0119	Excess Pressure: shutdown limit exceeded
E:0125	Temperature Sensor Fault: signal out-of-range (<-50°C or >250°C)
E:0129	Excess Temperature: shutdown limit exceeded
E:0821	Power Supply Analog Inputs Low
E:0866	Power Supply 24V DC low

Wiring Schematics

The following wiring schematics are provided for reference and example purposes only. Some terminations may not be shown or may be incorrect for your application. Always refer to the wiring schematics and drawings specific to your compressor for the most accurate information.

List of Schematics and Drawings:

R5.5-11kW Fixed Speed - Direct Online (24437675 Rev F)

R5.5-11kW Fixed Speed - Star Delta (24153595 Rev G)

RS15-22kW Fixed Speed - Star Delta (47554348 Rev E)

R5.5-11kW Fixed Speed - Direct Online (24437675 Rev F)

REV. HISTORY		
REV. NO.	DATE	REVISIONS
1	17.04.2018	ORIGINAL RELEASE
2	17.04.2018	ORIGINAL RELEASE
3	17.04.2018	PAN MOTOR WIRING CONNECTION CHANGED FOR 11kW/11.5kW
4	17.04.2018	PAN MOTOR WIRING CONNECTION CHANGED FOR 11kW/11.5kW
5	17.04.2018	PAN MOTOR WIRING CONNECTION CHANGED FOR 11kW/11.5kW
6	17.04.2018	PAN MOTOR WIRING CONNECTION CHANGED FOR 11kW/11.5kW
7	17.04.2018	REVISED SIGNALS
8	17.04.2018	REVISED SIGNALS
9	17.04.2018	REVISED SIGNALS
10	17.04.2018	REVISED SIGNALS
11	17.04.2018	REVISED SIGNALS
12	17.04.2018	REVISED SIGNALS

- NOTE:
- APPROVED FUSED DISCONNECT OR CIRCUIT BREAKER PER LOCAL CODES MUST BE PROVIDED BY CUSTOMER
 - SEE PAGE 2 FOR 1PH REGION CONNECTIONS
 - SEE PAGE 2 FOR 3PH REGION CONNECTIONS
 - PAN MOTOR ALTERNATIVE CONNECTION FOR 575V POWER SUPPLY (PAN MOTOR CONNECTED IN DELTA)
 - SEE PAGE 2 FOR 3PH DELTA INTERNAL WIRING (ONLY INFORMATIVE, OTHER MANUAL NEEDS TO BE USED)
 - SEE PAGE 2 FOR 3PH DELTA EXTERNAL WIRING (ONLY INFORMATIVE, OTHER MANUAL NEEDS TO BE USED)
 - ENTER IN EUROPEAN VERSION POWERED SEPARATELY (NO APPROXIMATE TO VICES OPS AND PHASES PAU)
 - REMOTE START/STOP AND REMOTE LOAD/UNLOAD FUNCTIONS ARE MUTUALLY EXCLUSIVE
 - REMOTE FUNCTION SELECTION DEPENDS ON CONTROLLER PARAMETER SETTING

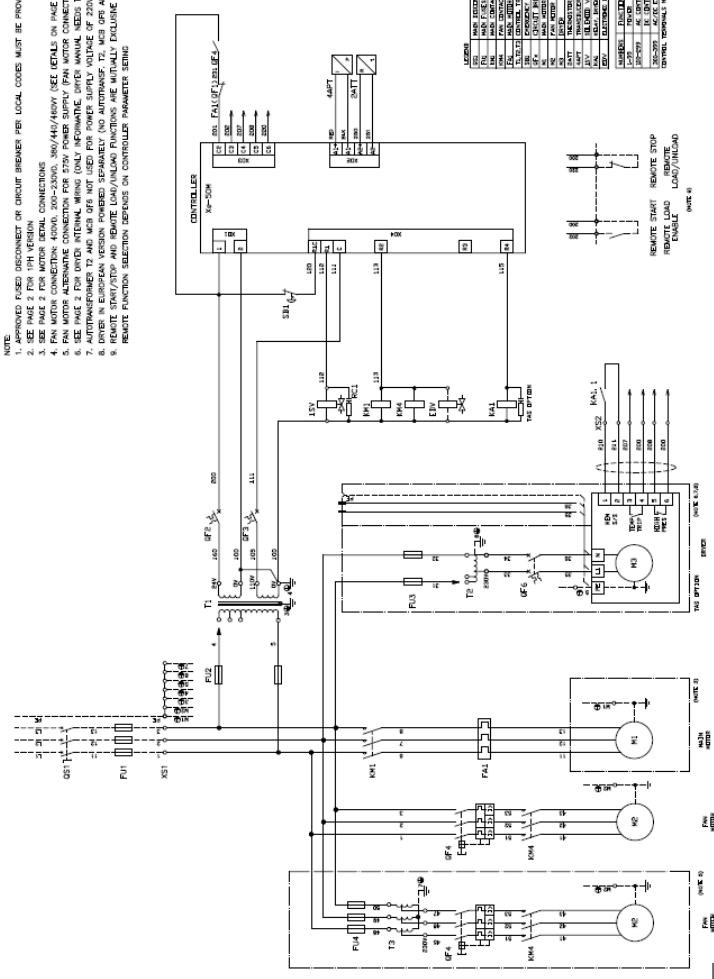

TERMINAL	FUNCTION
A	PHASE 1 (L1)
B	PHASE 2 (L2)
C	PHASE 3 (L3)
D	NEUTRAL (N)
E	GROUND (PE)
F	STOP (STOP)
G	START (START)
H	STOP (STOP)
I	START (START)
J	STOP (STOP)
K	START (START)
L	STOP (STOP)
M	START (START)
N	STOP (STOP)
O	START (START)
P	STOP (STOP)
Q	START (START)
R	STOP (STOP)
S	START (START)
T	STOP (STOP)
U	START (START)
V	STOP (STOP)
W	START (START)
X	STOP (STOP)
Y	START (START)
Z	STOP (STOP)

DECAL ELECTRICAL
WIRING, I/O, Xe-50M

Part No. **24437675**

REV. NO.	DATE	REVISIONS	DESCRIPTION
1	17.04.2018	ORIGINAL RELEASE	
2	17.04.2018	ORIGINAL RELEASE	
3	17.04.2018	PAN MOTOR WIRING CONNECTION CHANGED FOR 11kW/11.5kW	
4	17.04.2018	PAN MOTOR WIRING CONNECTION CHANGED FOR 11kW/11.5kW	
5	17.04.2018	PAN MOTOR WIRING CONNECTION CHANGED FOR 11kW/11.5kW	
6	17.04.2018	PAN MOTOR WIRING CONNECTION CHANGED FOR 11kW/11.5kW	
7	17.04.2018	REVISED SIGNALS	
8	17.04.2018	REVISED SIGNALS	
9	17.04.2018	REVISED SIGNALS	
10	17.04.2018	REVISED SIGNALS	
11	17.04.2018	REVISED SIGNALS	
12	17.04.2018	REVISED SIGNALS	

IR
Ingersoll Rand
DECAL ELECTRICAL
WIRING, I/O, Xe-50M
Part No. 24437675

XE-70M CONTROLLER INTRODUCTION

The Xe-70M control system is provides efficient and reliable compressor operation. The controller supports thirty languages, independently configurable units of measure as well as enhanced network and communication capabilities.

This microprocessor-based controller uses a finger touch membrane for operation of the compressor and setting control parameters.

Information about the programming and operating status is available on a Liquid Crystal Display (LCD) from a system of Folders and Pages.

The Xe-70M monitors compressor health and should any pre-programmed limit be exceeded the controller automatically displays a warning or issues a trip to shut the compressor down.

The major components of the control system include the controller, voltage transformer, and solenoid valves to control compressor operation.

A series of pressure sensors, temperature sensors, relays, and switches make up the instrumentation that provides feedback to the controller.

Operating and navigating the controller is easy and intuitive through a series of folders and pages within the controller user interface (GUI). The following explanation introduces and describes the major components that make up the Xe-70M control system. Always refer to the drawings and schematics for your specific compressor or application.

COMPONENT REVIEW

FU1 - Main Fuse Protection

FU1 is the schematic designation of the Main Fuse Protection and is the customer's responsibility to correctly size and install.

FU1 protects the machine should an overcurrent condition occur. These fuses should be time delay fuses, in order to accommodate the inrush current at machine startup. For an instant, the inrush current drawn by the machine can be several times greater than the full-load rating.

See the Engineering Data sheets in Sales Library for fuse and cable size recommendations.

FU2 and FU3 - Transformer Primary Protection

FU2 and FU3 (sometimes designated as FB1) are the schematic designations of the primary protection devices for the control transformer. FU2 and FU3 protect the control transformer should a short develop in the primary winding.

These are time-delay, current limiting type fuses. Current limiting is defined as being able to cut off a short-circuit current in less than one-half cycle (0.008 second, 60Hz).

The current rating of the fuses depends on the size of the control voltage transformer applied to the starter of the compressor.

T1 - Control Transformer

T1 is the schematic designation of the control transformer. A step-down transformer (T1) reduces the incoming line voltage to levels suitable for use with the Xe-70M control system. The reduced voltage sources are called

secondary circuits. There are two of these secondary circuits in the control system.

The first secondary circuit is rated at 110 Vac, 1 phase, 60Hz and is used to energize solenoid valves and starter coils. The “hot” connection is X1 and the neutral connection, X3, is grounded to the starter chassis.

The second secondary circuit is rated at 24 Vac, 1 phase, 60Hz and is used to power the Xe-70M controller and is also converted to a rectified 5 Vdc and 24 Vdc excitation voltage for machine sensors.



110 Vac Circuit - Transformer (T1) to Xe-70M

The Xe-70M controller receives 110 Vac from T1.

Depending on operating conditions, the controller sends the voltage onward to specific areas at specific times.

Examples: energizing a starter coil at start-up or energizing a solenoid valve when the compressor loads.

The circuit begins at X1 and connects to the Xe-70M in the following sequence:

QF3 - Circuit Breaker

QF3 (sometimes referred to as MCB3) is a circuit breaker on the 110 Vac secondary side of the control voltage transformer circuit to provide a degree of protection for the Xe-70M controller.

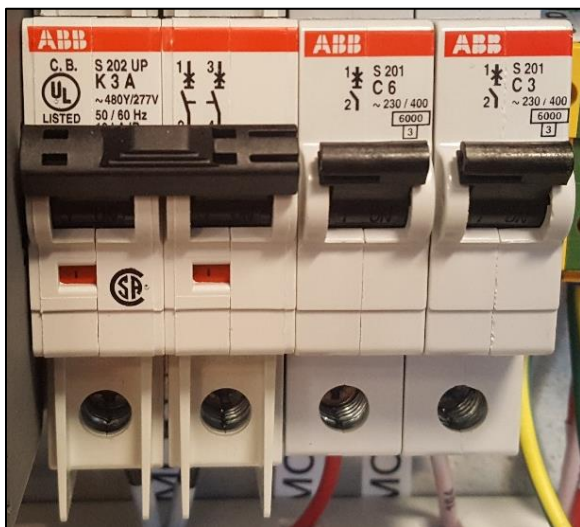

SB1 - Emergency Stop Button

SB1 (sometimes referred to as ES) is located next to the Xe-70M controller in the starter panel and is intended to stop the compressor in an emergency.

The switch has two sets of normally closed contacts that open when the red E-Stop button is pressed. Refer to the electrical schematics for the correct terminal location.

SB1.1 (ES-1) contact is located just after QF3 (MCB3) in the 110 Vac circuit and SB1.3 (ES-2) contact is located in the 24 Vdc logic circuit at X02 terminal DI1.

These contacts act in parallel to ensure power is removed from the starter coils, solenoids and logic system to cause the compressor to stop immediately. The switch will remain in the open position until manually reset by pulling the red E-Stop button forward.

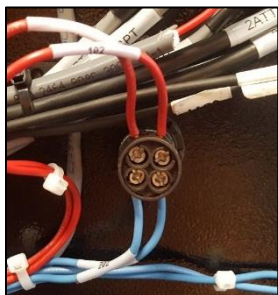

X01 - X13 Quick Connect Terminal Plug Strips

A group of different sized terminal plugs is used to connect control and instrument wires to the Xe-70M controller.

These connectors are female Phoenix type (5.08mm spacing) and plug into matching male receptacles on the Xe-70M controller. Devices and instrumentation connected through each plug are dependent on machine configuration as defined in the electrical schematic and label on the back of the Xe-70M controller cover. Caution should be used to ensure each plug is properly inserted into the correct receptacle.

Always refer to the electrical schematic that came with the compressor. These plugs are designed to be inserted in one direction only. The wiring schematic identifies the proper terminal plug for each device or instrument connected.

As an example, the 110 Vac circuit passes through a circuit breaker and Emergency Stop switch with the “hot” wire 111 connected to X09-1 and neutral wire 113 connected to X09-2.



X01 Analog Outputs

Terminal plug strip X01 is dedicated to providing a 4-20mA control signal the blower drive of premium efficiency machines.

X02 Digital Inputs

Terminal plug strip X02 is dedicated to digital inputs that provide remote control and feedback from various switches installed on the package.

DI2 - Main Motor Overload Relay (FA1 R-Series Only)

Connected to the bottom of KM1, the main motor overload relay provides protection in the event of an overcurrent condition in the motor windings. It is adjustable per the nominal current and service factor values found on the motor data tag.

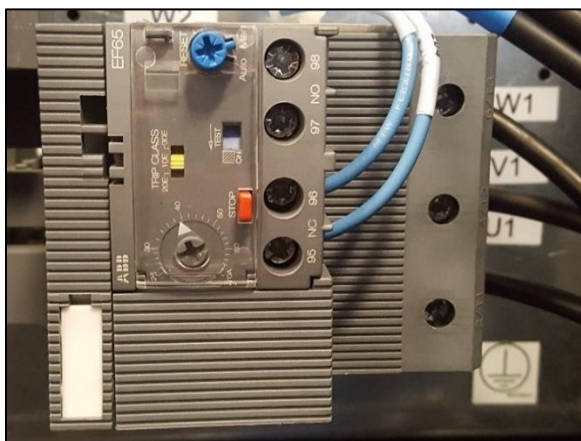

X03 Analog Pressure Sensor Inputs

Pressure transducers are used to convert air pressure signals to a voltage signal between 0.5 and 4.5 Volts DC.

The transducer contains a metal diaphragm connected to a small piece of steel called the beam which in turn has a strain gauge attached. As pressure pushes the diaphragm, the beam flexes and bends the beam and the strain gauge.

A continuous voltage is applied to the strain gauge assembly. As the strain gauge bends due to the changing pressure on the diaphragm, the resistance value through the strain gauge changes a corresponding amount; the result is a variable output signal that ranges from 0.5-4.5 volts.

The output signal is processed by an analog to digital converter within the controller. Depending on the voltage level, the controller may decide to cause a change in the pressure reading displayed, unload the compressor or possibly shut the compressor down if conditions dictate.

If a pressure sensor is replaced, it is important to calibrate the new sensor. Basically, calibration allows the controller to read the sensor's output signal with the diaphragm in a totally relaxed state and then correct for any minor deviations from .5 Vdc. Calibration directions are included in the Operator's Manual. There are no adjustments to the pressure sensors themselves.

3APT - Sump Pressure

Connected to X03-1 & 2, 3APT has a range of 0 to 232 psi. Power is provided to the transducer at X03-1 and return signal at X03-2. The output signal is 4mA at 0 psi and 20mA at 232 psi.

Sump pressure is monitored for several reasons including comparison to package discharge pressure during a separator element differential check and to provide logic for the controller to position the inlet valve during unloaded operation.

The normal unloaded sump pressure is maintained within a range of 18 to 24 psi to ensure adequate coolant flow and allow the unloaded compressor to operate at a low horsepower condition.

4APT - Package Discharge Pressure

Connected to X03-3 & 4, 4APT has a range of 0 to 232 psi. Power is provided to the transducer at X03-3 and return signal at X03-4. The output signal is 4mA at 0 psi and 20mA at 232 psi.

The controller monitors package discharge pressure in order to load or unload the compressor and is compared with the sump pressure during the separator element differential check.

X03 Analog Temperature Sensor Inputs

Temperature sensitive resistors called thermistors are used to monitor temperature changes at various points within the compressor package. They operate on a 5 volt DC circuit.

As the temperature of the sensor changes, either higher or lower, the resistance through the sensor changes a corresponding amount. As the output voltage varies due to the temperature changes, the voltage strength is processed by an analog to digital converter within the controller. Depending on the voltage level from the various sensors, the controller may decide to cause a change in the value displayed, delay a differential pressure reading until the compressor warms up or reposition the inlet valve slightly during cold unloaded operation. The controller may also provide a Warning about rising temperature or could possibly shut the compressor down with a Trip if operating conditions dictate.

2ATT - Airend Discharge Temperature Sensor

The controller uses 2ATT to monitor the temperature of the air/coolant mixture as it leaves the airend discharge port. Mounted at the discharge of the airend and connected to X03-5 & 6, 2ATT has a range between -10°F and 250°F. The signal is connected at X03-5 and ground

at X03-6. The output resistance is 10kOhms at 77°F and 413.9Ohms at 239°F.

Should 2ATT observe the temperature rise exceeding 228°F (109°C), the controller shuts the compressor down on a Trip. The display will show the word Tripped and the Trip Log will display High Airend Discharge Temperature.

X04, X05 RS485 Communication

The Xe-70M has one RS485 serial port located at terminal plug strip X04. Care should be taken to ensure proper wire polarity for communicating with integral sequencers, remote monitoring and compressor control through an Ingersoll Rand or other external system controller.

X07 Relay Outputs

Terminal plug strip X07 is dedicated to outputs that provide dry contacts for remote trip notification and the PORO alarm. These outputs are dry contacts rated for 110/110 Vac, 5 amp service.

PORO - Power Outage Restart Option (PORO Option Only)

Connected to X07-2, the controller provides power to the PORO horn. The PORO horn provides audible notice of a pending automatic machine start. This feature is only used on units with the PORO option. The use of the scheduled start/stop requires the PORO option to be enabled and a PORO horn to be installed for safety reasons.



CTO - Common Trip Outputs

N.O. output connected to X07-3 & 4

X08, X09 Triac Outputs

Terminal plug strips X08 and X09 are dedicated outputs that provide control of solenoid valves and starter contactors. These outputs are powered by 110 Vac located at X09-CR.

R1 - Main Motor Start Contacts (KM1, KM2)

Connected to X09-2, the controller provides power to KM1 and KM2 main motor starter coils.

Auxiliary contacts KM1-1, KM3-1 and KM3-2 provide full control of the Star/Delta starting circuit.

R2 - Main Motor Start Contact

Connected to X09-3, the controller provides power to KM3 main motor starter coil.

Auxiliary contact KM2-1 provides full control of the Star/Wye Delta starting circuit.

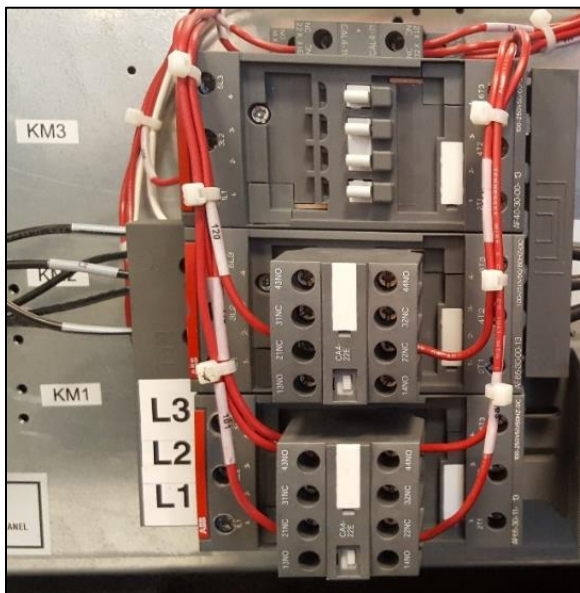

R3 - Fan Motor Start Contacts (KM4) R-Series Only

Connected to X9-4, the controller provides power to KM4 fan motor starter coil. KM4 provides control of the cooling fan motor starting circuit.



R4 - NC Load Solenoid Valve (1SV)

Connected to X08-2, the controller provides power to the 1SV load solenoid valve. When energized, 1SV opens and applies pressure to the inlet valve to allow the compressor to load.

R4 - NO Blowdown Solenoid Valve (3SV UP6S/RS Only)

Connected to X08-2, in parallel with 1SV, the controller provides power to the 3SV solenoid valve. When de-energized as the machine unloads or shuts down, 3SV opens to vent sump pressure to atmosphere.

R5 - Modulation Solenoid Valves (5SV and 6SV)

Connected in parallel to X08-3, 5SV and 6SV are used to control modulation (6SV only used in UP6S).

When the package discharge pressure is between the online and offline setpoints the compressor will adjust the inlet valve in order to achieve a stable output pressure. The output pressure target needs to be set by a technician at the inlet valve in order to provide effective modulation control.

Modulation can only work when the package discharge pressure is above 60 psi. Modulation is an option and must be enabled in the factory settings tab.

R5 - Dryer/Blower Drive Relay (KA1 TAS Option Only)

Connected to X08-4, the controller provides power to the KA1 (sometimes referred to as K1) dryer/blower drive control relay. KA1 provides control of the integrated dryer or blower drive relay circuit (optional components).



X10, X11 Current Transformer Analog Inputs

Current transformers (CTs), if equipped, provide real-time motor current input to the controller for motor protection. If CTs are equipped, the machine will not have a traditional main motor overload relay (FA1) and Motor Protection must be enabled in the controller's factory settings.

X13 24 Vac Power Supply Input

The controller operation is powered by a 24 Vac output from the secondary side of the T1 control transformer.

Xe-70M Controller I/O Summary

Digital Inputs

- X02-2 Emergency Stop ES-2
- X02-3 Fan Motor Protection FMP-1
- X02-4 Remote Load Enable RLE
- X02-5 Remote Load/Unload RLU
- X02-6 Remote Start RST
- X02-7 Remote Stop RSP
- X02-8 Dryer High Temperature Trip (TAS Option)
- X02-9 Dryer High Pressure Trip (TAS Option)

Analog Inputs

- X03-1 & 2 Sump Pressure Transducer 3APT
- X03-3 & 4 Package Discharge Pressure Transducer 4APT
- X03-5 & 6 Airend Discharge Temperature Thermistor 2ATT

Digital Outputs

- X07-2 PORO Horn (Option)
- X07-3 Common Trip Output CTO
- X07-4 Common Trip Output CTO
- X08-2 Load Solenoid Valve 1SV
Blowdown Solenoid Valve 3SV
- X08-3 Modulation Solenoid Valve 5SV
Modulation Solenoid Valve 6SV
Dryer Control Relay K1 (Option)
- X08-4 Low Ambient Control Relay K5 (Option)
- X09-2 Main Motor Starter Coil KM1
Main Motor Starter Coil KM2
- X09-3 Main Motor Starter Coil KM3

Xe-70M Controller Interface and Operation

The standard user interface configuration of the controller consists of the membrane and the LCD display. The membrane consists of five command keys (Start, Stop, Load, Unload, and Reset), four navigation keys (Up, Right, Left and Down), and an Edit mode selection key (Enter). These keys, in conjunction with the graphics display and LED icons, make up the user interface to the compressor.

Xe-70M Interface Layout

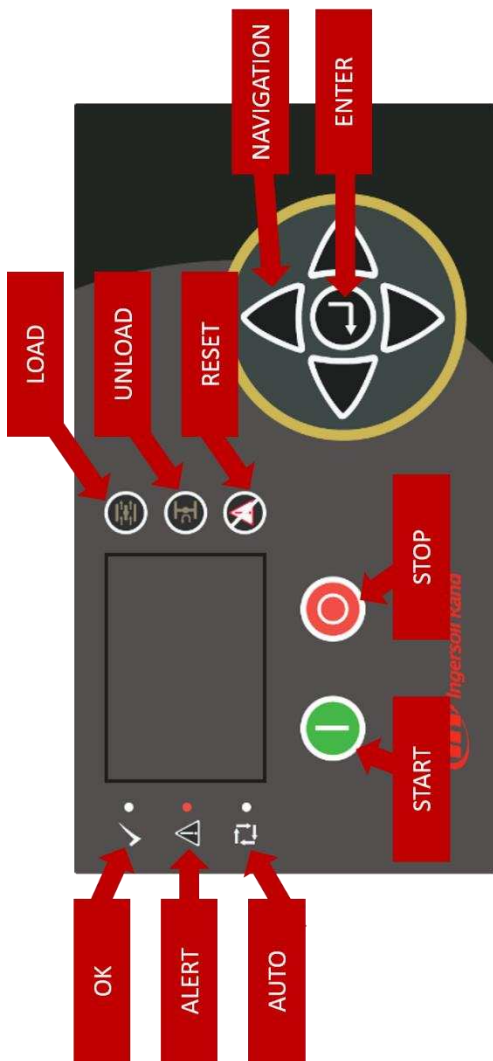

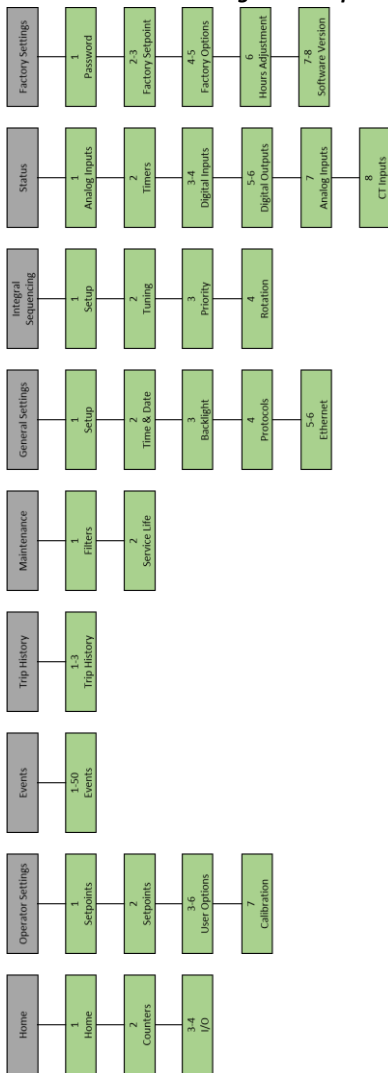

Xe-70M Menu Navigation Map









LED Status Icons

Three LED icons are used to indicate the current status of the control system from a distance and are located on the upper left side of the user interface.

Icon	Name	Function
	OK	Green Indicator, Illuminates when no Warnings or Trips are sensed, (can be in a Ready or Not Ready state). This icon will flash when the machine is Running Unloaded.
	Alert	Red Indicator, Illuminates when a Warning (flashes) or Trip (constant on) is sensed. Can be in a Ready (Warning) or Tripped state.
	Auto	Blue Indicator Illuminates when the compressor stops in auto restart.

Command Keys

These keys command the controller to perform actions as specified in the following table. When any of these keys are pressed the action below will be initiated and logged in the event log.

Icon	Name	Function
	Load	Places the compressor into the selected mode of operation. Unit will load if the pressure conditions are right.
	Unload	Places the compressor into an unloaded state. Unit will run unloaded indefinitely.
	Reset	Clears Warnings and Trips once the condition has been corrected.
	Start	Starts the compressor.
	Stop	Stops the compressor. This button should be pressed instead of the Emergency Stop for normal stopping operation.
	Enter	Toggles the display between the Navigation mode and the Edit mode.

Navigation Keys

There are four navigation keys (UP, RIGHT, DOWN and LEFT) that move a cursor throughout the folders and pages in the display. While the ENTER key is not considered a navigation key, it is used in conjunction with the navigation keys to make or confirm a selection.



Xe-70M's Navigation Keys

The navigation keys roll over. Pressing one of the navigation keys will lead the user down a navigation path. Each time the key is pressed, another step in the path is taken. Once the end of a navigation path is reached, pressing the key one more time will bring the user back to the beginning of the path. Pressing the opposite key will move the user through the navigation path in the opposite direction. Once the beginning is reached, pressing the opposite key will take the user to the end of the path.

Display Layout

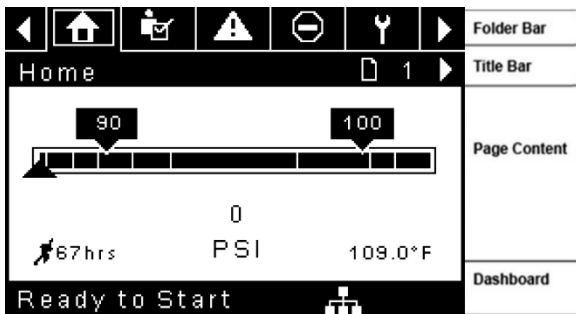

Xe-70M Display Layout

Folder Bar: Uses tabs to graphically identify each folder.



Title Bar: Identifies current folder and page.





Page Content: Content of the current page.

Dashboard: Displays system status.

Folder Navigation & Icons



To move among the tabbed folders shown on the LCD display, press the RIGHT and LEFT keys. The navigation rolls over from the last to the first folder and vice-versa.

Folder Name	Icon	Description
Home		System performance and status main information. The first page of this folder is the default page at power up.
Operator Settings		System options and configuration settings.

Folder Name	Icon	Description
Events		System events log.
Trip History		Details on the most recent trips.
Maintenance		Status and notification setup for compressor maintenance items.
General Settings		General settings such as Language, Time, and Units of Measure.

Page Navigation

Once the desired folder is selected, press the DOWN key to move to the page selection area and then use the RIGHT and LEFT keys to select the desired page. Use the UP key to get back to the folder tabs.

Icon	Description
	Start of the page selection area.
	Indicates that there are more pages available by navigating right.
	Indicates that there are more pages available by navigating left.

Accessing Parameters

After the desired page is selected, the page's parameters can be selected by using the DOWN key. The cursor will move to the next parameter each time the DOWN key is pressed. Use the UP key to go back to the previous one.

The cursor rolls over, so once the last parameter is selected, pressing the DOWN key will navigate the cursor to the Folder Bar. If the first parameter is selected, pressing the UP key will move the cursor to the page selection area.

Once selected, access parameters by pressing the ENTER key. Make changes using the UP and DOWN NAVIGATION keys and then enter the setting by pressing the ENTER key again. After a parameter is accessed, pressing the ENTER key will enter the current setting into the control program and navigate the cursor back to the selected parameter on the page.

When the cursor is on a parameter that has an enabled/disabled box, pressing the ENTER key will cause the setting to toggle.







This icon appears on numeric entry windows (see Figure below). Placing the cursor on it and then pressing the ENTER key will cancel the entry and any changes that were made.

Online Pressure	
Current value	90
New value	90
	<input type="button" value="X"/>

Numeric Entry Window

Dashboard Icons

The dashboard is intended to be a quick at-a-glance view of system status. The following table lists standard dashboard icons and their definition.

Name	Icon	Description
Remote Control		Integral Sequencing communication status and configuration.
Service Required		Notification that one or more maintenance items are due for service.
Unloaded or Loaded	 	Compressor is in the unloaded state. Compressor is in the loaded state.

Dashboard Status Messages

The dashboard also displays the current operating state of the compressor. The following states may be encountered during machine operation:

- **Ready to Start** - The compressor currently has no trip or start inhibit conditions present. The machine can be started by pressing the start button at any time.
- **Starting** - A start command has been given to the compressor and the start sequence is being performed. The time period for this state can vary depending on the starter type of the machine.
- **Load Delay** - The compressor is waiting for a small period of time after starting before allowing the machine to load. This ensures the machine is at operating conditions before loading

- **Running Loaded** - The compressor is operating and producing air. The inlet valve is open and the blowdown valve is closed.
- **Running Unloaded** - The compressor is operating, but not producing air. The inlet valve is closed to the unloaded position and the blowdown valve is open.
- **Reload Delay** - This is a brief period of time after the compressor has unloaded before it is allowed to load again. This allows the inlet and blowdown valves time to reach their proper positions.
- **Auto-Restart** - The compressor has stopped due to pressure rising above the offline or auto-stop settings and auto-restart is enabled. The compressor will automatically restart when pressure falls to the online or target pressure setpoint.
- **Stopping** - The compressor has received a stop command and the stop sequence is being performed
- **Blowdown** - The compressor must wait for a brief period of time after stopping its motor before it is allowed to start again. The compressor will restart at the end of the blowdown period if a start command is received during blowdown.
- **Not Ready** - The compressor has detected a condition that will not allow the compressor to start. The condition must be corrected before a start is allowed, but does not need to be acknowledged or reset on the controller.
- **Tripped** - The compressor has detected an abnormal operational condition that has stopped the machine. The condition must be corrected and trip acknowledged by hitting the reset button before the compressor can start.
- **Processor Init** - The controller is being initialized.

Home Folder

Page 1: System Overview

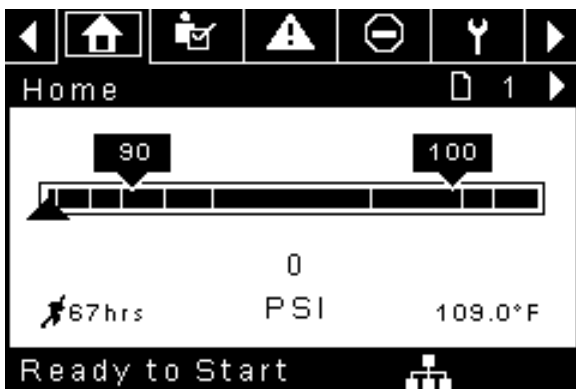

This is the factory default display after powering up the system.

- **Online Pressure Setpoint** - indicated in the black box and arrow, which is always left of center on the gauge. The compressor will load when package discharge pressure falls below this value.
- **Offline Pressure Setpoint** - indicated in the black box and arrow, which is always right of center on the gauge. The compressor will unload when package discharge pressure rises above this value.
- **Package Discharge Pressure** - indicated by the large numbers centered below the gauge and by the black arrow below the gauge. This is the air pressure that the compressor is supplying to the plant.
- **Pressure Unit of Measure** - indicated below the Package Discharge Pressure. This is selectable from the GENERAL SETTINGS folder.

- **Airend Discharge Temperature** - indicated by the numbers in the lower right of the display. This is the temperature of the air/oil mixture at the discharge of the compression module.
- **Temperature Unit of Measure** - indicated to the right of the Airend Discharge Temperature. This is selectable from the GENERAL SETTINGS folder.
- **Run Hours** - indicated by the numbers in the lower left of the display. The number of hours the compressor motor has been running.

NOTE: *The online and offline set points can be selected and modified on this page. All other information on this page is read only.*

Page 2: Counters

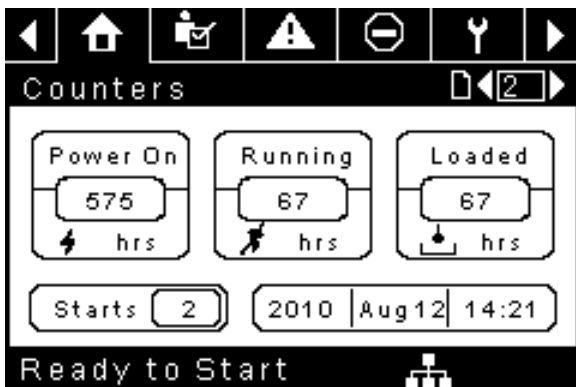

- **Hour Meters** - Indicates the hours that: the controller has been powered up, the compressor motor has been running, and the compressor has running loaded.
- **Starts** - Indicates the number of times a start is attempted on the compressor.
- **Date & Time** - Indicates the current date and time. This is adjustable and configurable in the GENERAL SETTINGS folder.

NOTE: All information on this page is read only.

Pages 3 & 4: Analog Inputs and Compressor Information

I/O	
Pack. Dis. Pres.	0 PSI
Sump Pressure	0 PSI
Airend Dis. Temp	109.0°F
Afterc. Dis Pres	0 PSI

Ready to Start

I/O	
Sep Pres Drop	3 PSI
Dryer Running	<input type="checkbox"/>
Time and date	14:24 12/08/2010

Ready to Start

Any sensor that is not installed or is reporting a failure will show a [- -] symbol.

NOTE: All information on these pages is read only.

The following analog inputs are displayed in this section.

- **Package Discharge Pressure** - The pressure the compressor is delivering to the plant
- **Sump Pressure** - The compressor's internal pressure at the sump tank.
- **Airend Discharge Temperature** - The temperature of the air/oil mixture at the discharge of the compression module.
- **Aftercooler Discharge Temperature** - The temperature of the air after passing through the Aftercooler. *Note - Only shown when the Low Ambient option is purchased and installed.*
- **Aftercooler Discharge Pressure** - Pressure the compressor is delivering before the dryer. *Note - Only shown when the TAS option is purchased and installed.*
- **Separator Pressure Drop** - The pressure drop across the separator element
- **Dryer Run Status (Integrated dryer units only)** - Checkbox that shows whether the dryer is currently running (checked) or not (blank)
- **Time and Date**
- **Main Motor Current** - Current flowing through the main motor

Operator Settings Folder

Pages 1 & 2: Operator Settings

Setpoints	
Online Pressure	90 PSI
Offline Pressure	100 PSI
Lead/Lag Select	<input checked="" type="checkbox"/>
Lag Offset	2 PSI
Ready to Start	

Options	
Operation Mode	Online/Off
Unload stop time	10 SEC
Starter Time	10 SEC
Ready to Start	

The below values are all setpoints:

Online Pressure - The compressor will load when the package discharge pressure falls below this value Range (in PSI): 65 to Offline Pressure - 10

Offline Pressure - The compressor will unload when package discharge pressure rises above this value. Range (in PSI): 75 to Rated Pressure + 10

Lead/Lag - When this box is checked the compressor is operating as a lead machine. Unchecking the box causes the machine to run as a lag machine.

Lag Offset - If the machine is running as a lag compressor, the lag offset will be subtracted from the online and offline setpoints. *Range (in PSI): 0 - 45, depending on the online and offline setpoints. The Lag Offset will never allow you to exceed the minimum or maximum values of the online and offline setpoints.*

Mode of Operation - Selections are Online/Offline, Modulation/ACS, and Modulation only - determines how the compressor will try to maintain a specific pressure.

- **Online/Offline** - The compressor will load the machine by energizing a solenoid that opens the inlet valve and closes the blowdown valve when package discharge pressure falls below the online pressure setpoint. The compressor will unload the machine by de-energizing the solenoid when pressure rises above the offline pressure setpoint.
- **Modulation** - The compressor will still load and unload as in online/offline, but will energize a different solenoid valve for modulation. When the package discharge pressure is between the online and offline setpoints the compressor will adjust the inlet valve in order to achieve a stable output pressure. The output pressure target needs to be set by a technician at the inlet valve in order to provide effective modulation control. Modulation can only work when the package discharge pressure is above 60 psi. Modulation is an option and must be enabled in the factory settings tab.

- **Mod/ACS** - The compressor will initially start out in online offline mode. If the compressor goes through 3 load/unload cycles within 3 minutes, it will switch over into Modulation mode. It will remain in modulation until the stop button is pressed or 3 minutes pass between an unload and load command. Mod/ACS is an option and must be enabled in the factory settings tab.

Unloaded Stop Time - Time period that the machine must run unloaded before the motor is allowed to stop after a stop command is received. *Range (in seconds): 10 - 30*

Starter Time - Time period that the compressor needs in order to come up to operating speed after a start command before being able to produce air. *Range (in seconds): 5 - 30*

The parameters on these pages are adjustable any time.

NOTE: *Mode of Operation can only be adjusted if the modulation option has been purchased for the compressor and the Enable Modulation factory setpoint has been turned on.*

Pages 3 - 6: Operator Options

Options	
En. Auto Restart	<input type="checkbox"/>
Auto-R. Time	120 SEC
Auto-R. D. Time	0 SEC
Comm control	<input checked="" type="checkbox"/>
Ready to Start 	

Options	
Rem Start-Stop	<input type="checkbox"/>
Enable PORO	<input type="checkbox"/>
PORO Time	10 SEC
Low Amb. Temp.	35.0°F
Ready to Start 	

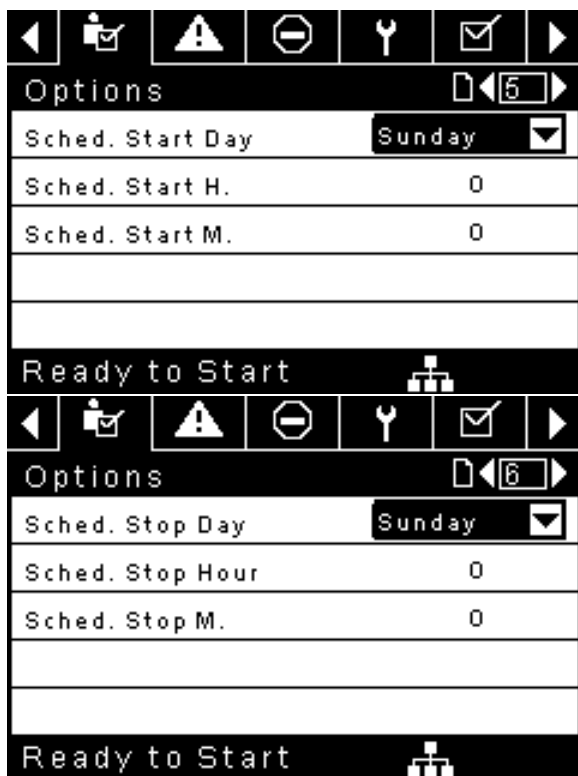

The below values are all setpoints:

Enable Auto-Restart - Enabling this will allow the compressor to stop if it has been running unloaded for a period of time, and the motor has exceeded its minimum running time (10 minute in most cases).

Auto-Restart Time - The time period the compressor must run unloaded before stopping in auto-restart. This time period begins the moment that package discharge

pressure rises above the offline setpoint. Both this time period and the minimum motor run timer (10 minutes) must be satisfied before the compressor will stop in auto restart. *Range (in seconds) 120 - 3600*

Auto-Restart Delay - The time period after the package discharge pressure has fallen below the online setpoint before the compressor can automatically restart. *Range (in seconds): 0 - 60*

COM Control - Enabling this setpoint allows the compressor to be controlled by a serial or Ethernet device, such as an X8I. This is equivalent to the “Sequencer” option on older Intellisys controllers.

Remote Start/Stop - Enabling this setpoint allows the compressor to be started and stopped using the digital inputs on the controller.

Enable PORO - Enabling this setpoint will allow the compressor to automatically restart after a power outage has been restored if the compressor was running loaded at the time of the outage. *PORO is an option and the option module must be purchased and installed before this feature can be turned on.*

PORO Time - Time after the controller power has been restored and controller has finished booting before the compressor will perform a PORO start. During this time the PORO Horn will sound. *Range (in seconds): 10 - 600*

Low Ambient Temp - Temperature below which the low ambient option will come into effect. *Range (in degF): 30 - 60*

Scheduled Start Day - Day (or days) of the week for which a scheduled start will be performed. The compressor will start when its onboard clock matches the

day, hour, and minute of the scheduled start setpoints. *Scheduled Start/Stop is an option and the option module must be purchased and installed before this feature can be turned on.*

Scheduled Start Hour - Hour of the day for which a scheduled start will be performed. *Scheduled Start/Stop is an option and the option module must be purchased and installed before this feature can be turned on.*

Scheduled Start Minute - Minute of the hour for which a scheduled start will be performed. *Scheduled Start/Stop is an option and the option module must be purchased and installed before this feature can be turned on.*

Scheduled Stop Day - Day (or days) of the week for which a scheduled stop will be performed. The compressor will stop when its onboard clock matches the day, hour, and minute of the scheduled stop setpoints. *Scheduled Start/Stop is an option and the option module must be purchased and installed before this feature can be turned on.*

Scheduled Stop Hour - Hour of the day for which a scheduled stop will be performed. *Scheduled Start/Stop is an option and the option module must be purchased and installed before this feature can be turned on.*

Scheduled Stop Minute - Minute of the hour for which a scheduled stop will be performed. *Scheduled Start/Stop is an option and the option module must be purchased and installed before this feature can be turned on.*

Note: *In order to disable Scheduled Start/Stop, the Scheduled Start and Stop days, hours, and minutes must match exactly.*

* The low ambient temperature is only adjustable if the low ambient factory set point is on.

** A value of 0 will disable the lead/lag cycle time feature.

Page 7: Sensor Calibration

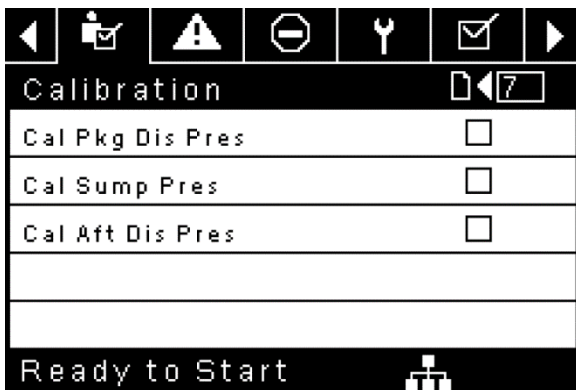

Sensor calibration can only take place when the machine is stopped and there is no pressure on the sensor. Calibration should only be performed after a sensor is replaced, the controller is replaced, the controller software is upgraded or the operator suspects the sensor reading is in error. Calibrate a sensor by selecting the checkbox beside the sensor name.

Each of the sensors listed below can be calibrated.

- Sump Pressure (3APT not included in R4-11kW machines)
- Package Discharge Pressure (4APT)
- Aftercooler Discharge Pressure (7APT) - *Only on units with integrated dryer*

Note: *If a sensor is currently reading a value that is +/- 10% of its range from zero, the sensor will not be able to be calibrated and a warning will be logged in the event log. Always make sure the sensor is exposed to atmosphere before attempting calibration.*

Events Folder

Pages 1 to a Max of 50: Event History



The pages in the Events folder document up to the last 250 events that the controller has experienced, with the time and date of the occurrence. The events are recorded in sequence, with number one being the newest and 250 being the oldest. When a new event occurs, it becomes number one and all others are shifted up in number.



The page numbers in the Title Bar are used to scroll through the events, with each page displaying up to five. Page one displays events one through five, page two displays six through ten, and so on.

The time and date of the event can be viewed by navigating to an event and pressing the right arrow navigation key. The time and date window can then be exited by pressing the enter key.



The following items will generate an event.

- Power On
- Power Off
- Press the Start Key
- Press the Stop Key
- Press the Load Key
- Press the Unload Key
- Starting the compressor remotely
- Stopping the compressor remotely
- Loading the compressor remotely
- Unloading the compressor remotely
- Warning
- Trip
- Start Inhibit

Active Warnings will show a flashing caution icon  while acknowledged Warnings will have a solid icon. Active Trips will show a flashing trip icon  while acknowledged Trips will have a solid icon.

Active Start Inhibits will be listed in the Event log, but not have an icon present. The display will indicate the compressor is not ready to start if a start inhibit is active.

Warning Events List

- **Sensor Failure - Xe-70M On-Screen Text: 7ATT Failure**

This will occur whenever sensor 7ATT is recognized as missing or broken. The sensor failure message shall follow the following format: 7ATT FAILURE. The 7ATT sensor failure will be shown only when the integrated dryer is installed (accessed in the factory settings menu). This condition must exist for 3 seconds before the warning is issued.

- **Change Separator Element - Xe-70M On-Screen Text: Chg Sep Elem**

Will occur if the unit is loaded, the package discharge pressure (4APT) is at least 90 psi and the separator pressure drop is greater than 12 psi. This condition must exist for 3 seconds before the warning is issued.

- **High Airend Discharge Temperature - Xe-70M On-Screen Text: High A/E Disch T**

Will occur if the unit is running and 2ATT is greater than 221°F (97% of 228°F) and the unit is running. This condition must exist for 3 seconds before the warning is issued.

- **High Sump Pressure - Xe-70M On-Screen Text: High Sump Pres**

If the unit is running loaded, has been loaded for at least 8 seconds and the sump pressure is more than 25 psi above the rated pressure for the compressor. If this warning occurs, the online and offline pressures will be reduced. For example, a rated pressure of 100 psi would have a maximum offline pressure of 110 psi. This

warning would occur if the sump pressure goes above 125 psi in this example. This condition must exist for 3 seconds before the warning is issued.

Service

Service warnings occur when the unit has operated a certain number of hours, based on the total hours. Service warnings can have multiple levels, depending on the service level selection. A service level selection of 0 disables service warnings.

- **Service Level 1** - *Xe-70M On-Screen Text: SVC Required*

If service level 1 has been selected for the unit, a “SERVICE REQUIRED” warning will be issued on hour intervals equal to the service time period set point. This warning can be reset the same as any other warning.

- **Service Level 2** - *Xe-70M On-Screen Text: 100 hours to Svc, SVC Required, Service Alarm*

If service level 2 has been selected for the unit, the service complete factory set point will be used to clear a level 2 service warning and reset the service time or date. The service complete can be reset before a service warning occurs.

The initial “SERVICE REQUIRED” warning will occur at total hour intervals equal to the service time period set point. However, 100 hours before this a “100 HOURS TO SERVICE” warning will occur. This warning can be reset the same as any other warning. One hundred hours later the “SERVICE REQUIRED” warning will occur. This warning can be reset the same as any other warning, however this warning will return in 24 hours if the service complete factory set point has not be set. If the service complete has not been set, 100 hours later, the “ALARM - SERVICE REQUIRED” warning will be issued. This warning can only be cleared by the service

complete factory set point. Once the service complete factory set point is set, indicating the service is completed, the time for the next "SERVICE REQUIRED" warning will be calculated by adding the service time period to the total hours value, with the "100 HOURS TO SERVICE" warning occurring 100 hours before and the "ALARM - SERVICE REQUIRED" warning occurring 100 hours after that time.

- **High Discharge Pressure - Xe-70M On-Screen Text: High Disch Pres**

Will occur if the unit is using a remote sensor or is under the control of an external device, such as an X8I, is loaded, and the discharge pressure (4APT) is greater than the maximum offline pressure. This condition must exist for 3 seconds before the warning is issued. If this condition occurs, the compressor will automatically unload. The unit will be available to reload once the discharge pressure falls to the rated pressure value.

- **Dryer Temp Warning - Xe-70M On-Screen Text: Dryer Temp**

This will occur if the dryer condenser or evaporator temperature switches close. The condenser switch is locking and must be manually reset before performing a reset on the controller. The evaporator switch does not latch and can be reset as soon as the signal opens. If this warning is reset while the conditions for running the dryer exist, the dryer can restart.

- **Dryer High Pressure - Xe-70M On-Screen Text: Dryer High Pres**

On units with the integrated dryer, this will occur if the dryer high pressure switch opens while the dryer is running. This is a dryer fault. If this happens, the compressor will continue to run, but the dryer will stop.

The contact must be open for at least 3 seconds before the warning will occur. However, this switch is a locking switch. The dryer high pressure switch must be reset (contact closed) before this warning can be reset. If this warning is reset while the conditions for running the dryer exist, the dryer can restart.

- **Change HE Filter** - *Xe-70M On-Screen Text: Change HE Filt*

The HE filter is located between the aftercooler discharge and the inlet to the dryer and is only on units with an integrated dryer. The drop across the HE filter is measured by subtracting the package discharge pressure from the aftercooler discharge pressure. If the compressor is running, the measured drop across the HE filter is at or above 14 psi (0.7 bar) and the package discharge pressure (4APT) is above 90 psi, this warning can occur. The condition must exist for at least 3 seconds before the warning will occur. This is not a dryer fault. If this happens, the warning will be displayed, but the dryer will continue to run.

- **Invalid Calibration** - *Xe-70M On-Screen Text: Invalid Cal*

Will occur if the sensor zero value is +/- 10% of its scale. See Sensor Calibration.

Trip Events List

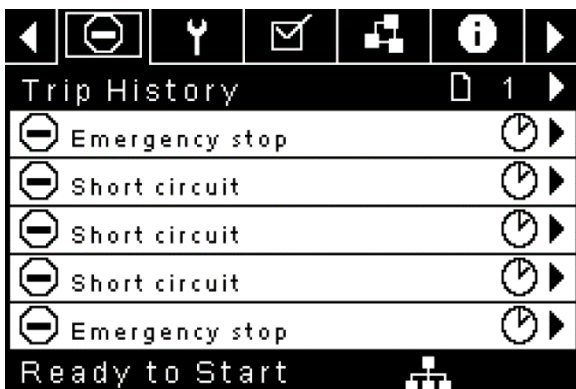

- **Low Sump Pressure** - *Xe-70M On-Screen Text: Low Sump Press*
Will occur if the unit is running unloaded or loaded and 3APT is less than 13 psi for 15 seconds.
- **High Airend Discharge Temperature** - *Xe-70M On-Screen Text: High A/E Disch T*
This will occur if 2ATT is greater than 228°F and the unit is running.
- **Check Motor Rotation** - *Xe-70M On-Screen Text: Ck Motor Rot*
This will occur if 3APT is less than 1 psi on a unit, 3 seconds after starting (6 seconds if the unit is equipped with a soft starter or airend discharge temperature is less than 50 degF). This condition can be caused by the motor running in reverse. Once correct motor rotation is established, this trip will not be checked again unless power is removed from the controller. However, if correct motor rotation is not established, this fault will be

checked after each start until correct motor rotation is established. Correct motor rotation is established when the controller reads a sump pressure of 1 psi or more within 3 seconds of starting.

- **Overload** - *Xe-70M On-Screen Text: Overload*
This will occur if the fan or motor overload relays opens. The contact must be open for at least 3 seconds before the trip will occur.
- **Remote Stop Failure** - *Xe-70M On-Screen Text: Rem Stop Fail*
Will occur if the remote start/stop option is enabled, the remote stop button remains open and either start button is pressed.
- **Remote Start Failure** - *Xe-70M On-Screen Text: Rem Start Fail*
Will occur if the remote start/stop option is enabled, the unit is started by the remote start button, and the button stays closed for 7 seconds after the unit starts.
- **Sensor Failure** - *Xe-70M On-Screen Text: 3APT Failure, 4APT Failure, 7APT Failure, 2ATT Failure, CT Failure*
This will occur when a sensor is recognized as missing or broken. The sensors affected by this trip are CT1, CT2, CT3, 3APT, 4APT, 7APT, and 2ATT. The sensor should be displayed along with the sensor failure message. The sensor failure message shall follow the following format: 3APT Failure.
- **Emergency Stop** - *Xe-70M On-Screen Text: Emergency Stop*
This will occur when the EMERGENCY STOP button is engaged.

- **High Sump Pressure** - *Xe-70M On-Screen Text: High Sump Pres*

This will occur if the compressor is running loaded for at least 8 seconds, and any one of the 3 following conditions exist. (1) The sump pressure is above the rated pressure by 35 psi. (2) The separator pressure drop is measured to be more than 25 psi and the package discharge pressure at least equal to the minimum online set point value. (3) The sump pressure is above 165 psi if the rated pressure is less than 190 psi or the sump pressure is above 220 if the rated pressure is 190 psi.

- **Unit Too Cold To Start** - *Xe-70M On-Screen Text: Unit Too Cold*

This will occur if the unit does not have the low ambient option, the airend discharge temperature (2ATT) is less than 35 deg F, and the operator attempts to start the compressor. This fault can only occur once a day. Once this fault occurs, the operator can reset it and start the compressor. This fault will be logged in the trip history to indicate that the unit is being started in low ambient conditions.

Start Inhibit List

- **High Airend Discharge Temperature** - *Xe-70M On-Screen Text: High A/E Disch T*

This will occur if 2ATT is greater than 95% of 228°F.

- **High Sump Pressure** - *Xe-70M On-Screen Text: High Sump Pres*

This will occur if the sump pressure (3APT) is 25 psi or higher than the rated pressure of the compressor.

Trip History

Pages 1 to a Max of 3: Trip History

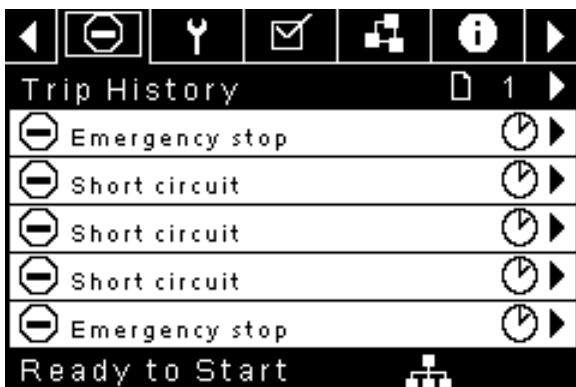

The pages in the Trips History folder document up to the last 15 trips that the controller has experienced and time stamps each. The trips are recorded in sequence, with number one being the newest and 15 being the oldest. When a new trip occurs, it becomes number one and all others are shifted up in number. The page numbers in the Title Bar are used to scroll through the events, with each page displaying up to seven. Page one displays events one through five, page two displays six through ten, and so on.

Active Trips will show a flashing trip icon  while acknowledged Trips will have a solid icon.

The trip history also records compressor data at the time of the trip to assist in diagnostics and troubleshooting. Navigating to the trip entry and hitting the right navigation button will bring up the trip history dialog box.



While the dialog box is active, press the left and right keys in order to scroll through the displayed data. The name of the trip will always be shown in the title bar of the dialog box. Press enter when finished viewing the data to return to the trip history screen.

Maintenance Folder

Page 1: Filter Status



This page displays the status of the filters. The filter status will either be “OK” or “Change” depending on the compressor’s diagnostic readings. If a filter reaches the “change” status, a warning will be issued and the service indicator will light up to notify the user. *Note that the compressor must be in a “Running Loaded” state to check these maintenance items.* If the compressor is not in a running state - the status will display “Load,” unless a maintenance indicator has been issued when the machine was running and has not yet been reset.

The following filters are displayed:

- Separator Element

Page 2: Maintenance Configuration

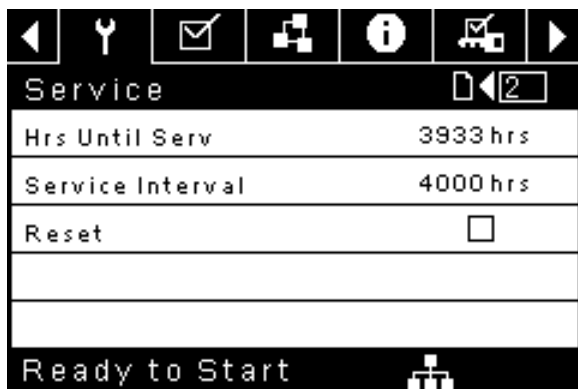

The screenshot shows a control panel interface with a top navigation bar containing icons for back, wrench, checkmark, separator, information, and forward. Below the navigation bar is a header area with the word "Service" and a numeric display showing "2". The main content area is a table with the following rows:

Hrs Until Serv	3933 hrs
Service Interval	4000 hrs
Reset	<input type="checkbox"/>

At the bottom of the screen, there is a status bar that reads "Ready to Start" and a separator icon.

This page allows the user to set the service interval and to reset the counter after the service has been performed. The service interval may be set to any value between 1000 and 8000 hours, but must be set in accordance with the factory maintenance schedule. After maintenance has been performed, the user can reset the counter by navigating to the Reset button and pressing the enter key.

Note: After changing the Service Interval a Reset must be performed to set the Hours Until Service to the proper value.

General Settings Folder

Page 1: Language and Units Selection

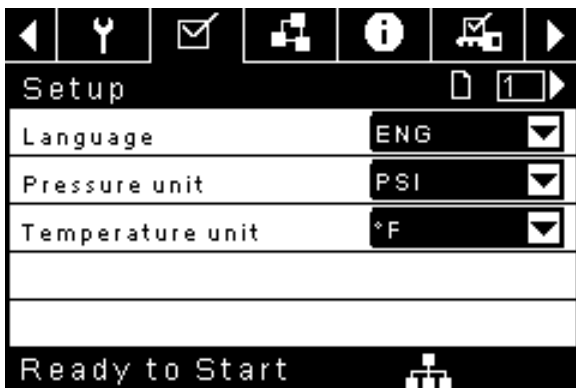

Language is selectable from the following 30 selections:

English (default)	Finnish	Latvian
Slovak	Bulgarian	French
Lithuanian	Slovenian	Chinese, simplified
German	Maltese	Spanish
Croatian	Greek	Norwegian
Swedish	Czech	Hungarian
Polish	Thai	Danish
Italian	Portuguese	Turkish
Dutch	Indonesian	Romanian
Estonian	Korean	Russian

The controller will display all screens in the selected language and only one language can be selected at a time.

Each language appears in its native translation.

Temperature is selectable between °F and °C.

Pressure is selectable between psi, kpa, bar, kg/cm².

Page 2: Time & Date Settings

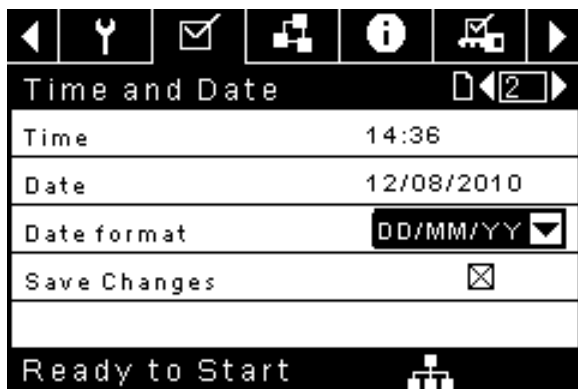

All items are adjustable.

Time allows the current time to be set in a 24 hour format.

Date allows the current month, day, and year to be set.

Date Format is selectable between dd/mm/yyyy (default), mm/dd/yyyy, and YYYY/MM/DD.

Confirm New Time and Date is used to verify that changes to selections are desired. An “x” must appear in the checkbox before any changes will take affect.

The controller will continue to display any changes, even when the selections have not been confirmed and the user exits the page, then returns. Cycling of the power returns all selections to their current settings.

Note: *The controller does not support Daylight Savings Time.*

Page 3: Backlight Settings



Backlight Brightness adjusts the brightness of the display.

Note: *The backlight will be switched on whenever any of the controller's keys are pressed.*

CAUTION: THE START, STOP, LOAD, UNLOAD, RESET, AND ACKNOWLEDGE KEYS ON THE CONTROLLER REMAIN FUNCTIONAL WHILE THE BACKLIGHT IS SWITCHED OFF. IT IS RECOMMENDED TO PRESS THE ENTER KEY OR ONE OF THE NAVIGATION KEYS IN ORDER TO SWITCH THE BACKLIGHT ON.

Page 4: Serial Port Address Settings

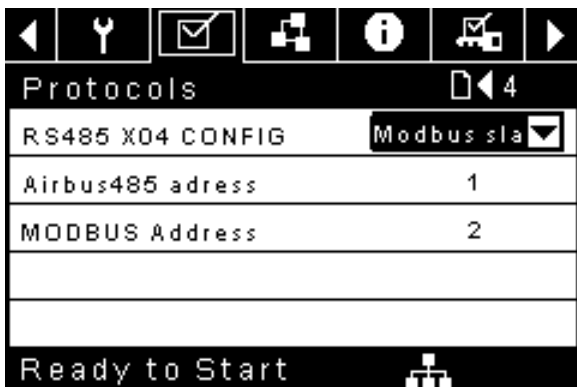

This page allows the user to set up the network addresses for the RS-485 networks the controller is capable of communicating with.

RS485 Protocol - Allows the serial port to be configured to Airbus (used for X-Series system controllers and integral sequencing) or Modbus protocols

MODBUS Address - Sets the modbus node ID for the controller to communicate with a Modbus capable device, this can be any value between 1 and 254.

Airbus Address - Sets the airbus address that allows the controller to communicate over Integral Sequencing or an X-Series system controller network.

Pages 5 - 7: Ethernet Settings (ECO Module Only)

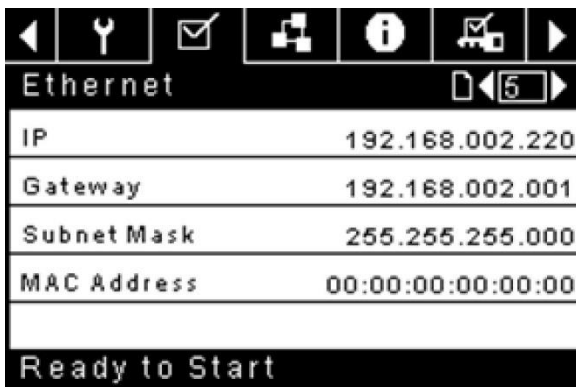

Ethernet	
IP	192.168.002.220
Gateway	192.168.002.001
Subnet Mask	255.255.255.000
MAC Address	00:00:00:00:00:00
Ready to Start	

IP Address Setting - When DHCP is not enabled, this setpoint sets the IP address of the controller.

IP Address Actual - This will match the IP address setting when DHCP is not enabled. If DHCP is enabled this will display the address assigned to the controller by the DHCP server.

Default Gateway Setting - Setpoint for the default gateway.

Default Gateway Actual - Current reading/setting for the default gateway.

Subnet Mask Setting - Setpoint for the subnet mask

Subnet Mask Actual - Current reading/setting for the subnet mask

MAC Address - This is the unique hardware MAC address for the controller. This can not be changed.

Enable DHCP - Allow the controller to automatically receive an IP address from the Local Area Network (LAN)

Apply - After editing the desired setpoint navigate to the accept setting and press enter in order for the values in the setting variables to be confirmed by the controller.

Cancel - Discard any changes made to the Ethernet settings.

Integral Sequencing Folder

Integral Sequencing allows the compressor to be networked with up to three other compressors (fixed or variable speed) to maintain a stable system pressure by loading and unloading compressors as needed. Integral sequencing requires no additional hardware other than a serial two wire connection daisy chained between all compressors in the system, connected to port X04 on the controller.

For a compressor to be a member of the integral sequencing system, the COM control setpoint in the operator settings tab must be enabled and the compressor must be started via the local start button. Additionally, it is recommended that the Auto-Restart function be enabled as the integral sequencing system will never start and stop machines, only load and unload them. Integral sequencing relies on Auto Restart to turn OFF the compressor motor when not needed.

Note: *The compressor's address in the integral sequencing system is defined by the RS-485 address that is set on the general settings folder. Also note that the pressure signal used to determine when to load or unload*

another compressor is based on the pressure reading from the compressor assigned as the integral sequencing master. Lastly, note that the Active Protocol on the general settings tab must be set to Airbus485 for integral sequencing to operate properly.

Certain functions may interfere with compressors loading and unloading:

- Verify that the Remote Load Enable switch is in the open position. Having this closed will allow the remote load/unload switch to define the load command.
- The master controller **MUST** be started and running in the sequence. Otherwise, compressors will revert to their local setpoints.
- If the master controller is telling a slave controller to load and the slave's local pressure is above its maximum offline setpoint, or its immediate stop setpoint, the slave will unload locally, and remain unloaded until pressure falls below online or target setpoints.

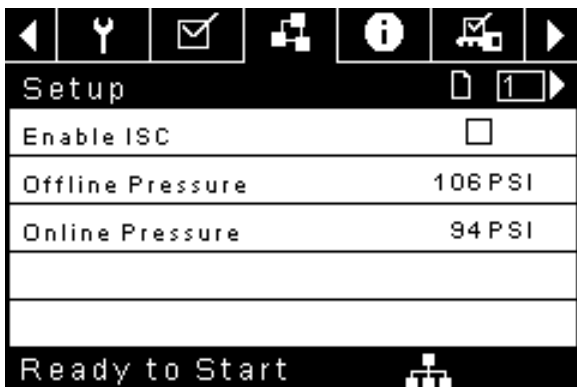

Integral Sequencing - Enabling Integral Sequencing chooses this compressor to be the sequence Master. The master's package discharge pressure sensor will be the pressure signal used for the system. The default is disabled. Make sure all compressors are set up for integral sequencing before enabling this function. It is important that only one compressor in the system have this setpoint enabled, otherwise system behavior could be impacted. This setpoint should also only be modified while the compressor is stopped. *Note that the Integral Sequencing master does not have to be the compressor assigned RS-485 address 1.*

Unload Pressure - Determines the pressure at which a compressor will be unloaded by the system. The system unload pressure should always be set lower than the local offline setpoint of compressors in the system. *Note that when under system control, the compressor will ignore the local pressure setpoints except for protective functions.*

Load Pressure - Determines the pressure at which a compressor will be loaded by the system. . The system

unload pressure should always be set lower than the local offline setpoint of compressors in the system. The system unload pressure should always be set lower than the local offline setpoint of compressors in the system. *Note that when under system control, the compressor will ignore the local pressure setpoints except for protective functions.*

Page 2: Tuning

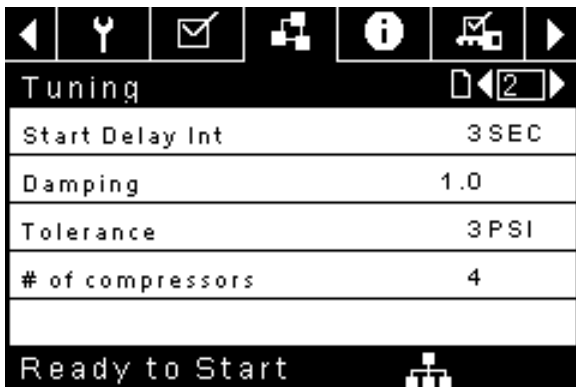

Tuning	
Start Delay Int	3 SEC
Damping	1.0
Tolerance	3 PSI
# of compressors	4

Ready to Start

Start Delay Interval - Determines the amount of time between loading compressors. This prevents all compressors from loading at once. This setpoint should be set to the longest starting time of any compressor in the system. In general, this will be equivalent to the star/delta transition time for a fixed speed machine, or ramp time for a VSD machine.

Damping - The pressure control “Damping” setting which is used to tune how quickly the system responds to pressure deviations. The default is 10 and should not normally be changed.

Tolerance - The pressure control “Tolerance” setting, which is used to tell the system how to respond to changes in pressure above and below the load/ unload pressures. The default is 3.0 psi and should not normally be changed.

Number of Compressors - Defines how many compressors are in the system. There is a maximum of 4.

Page 3: Priority

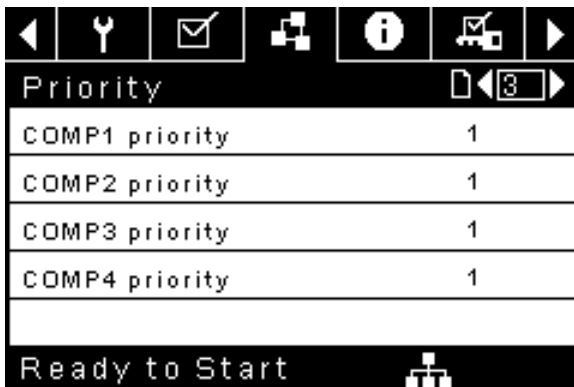

Priority	
COMP1 priority	1
COMP2 priority	1
COMP3 priority	1
COMP4 priority	1

Priority - Each compressor can be assigned a priority level. Setting a priority for a compressor affects how the rotation will occur. Compressors with priority 1 will always be in the lead position(s), followed by priority 2 compressors, and so on. Compressors will only rotate positions with other compressors of the same priority level.

Page 4: Rotation

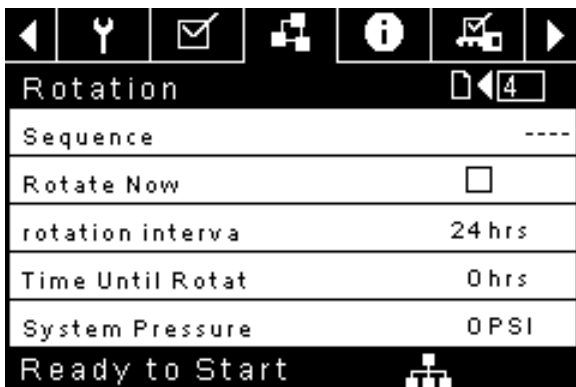

Sequence - Displays the current load/unload order of the system. Each compressor in the system is assigned a letter. The letter indicates whether the machine with the assigned Airbus address is a lead machine (loads first, unloads last) or one of the trim machines. Letter A is assigned to the lead machine, B to the next machine to load, C to the third machine to load, and D to the final machine to load. Machines will unload in the reverse order, such that A will be the last machine running. The first position in the - - - - sequence on Integral Sequencing tab, page 3 always refers to the compressor that is assigned Airbus Address 1. The second position to Airbus Address 2, and so on.

Note: *The letter sequence may change due to rotation. The sequence will only be displayed on the master controller.*

Rotate Now - Selecting this setpoint will cause the sequence to shift according to the priorities, regardless of the rotation interval setpoint.

Rotation Interval - Determines the time period between sequence rotations.

Time Left - Counts down the time until the sequence rotation will occur.

System Pressure - Shows the current pressure reading that the system is using for control. This will only be shown on the sequence Master controller.

Status Folder

***Note:** All information on these pages is read only. Some values may only be visible when the factory settings password is entered.*

Page 1: Analog Inputs

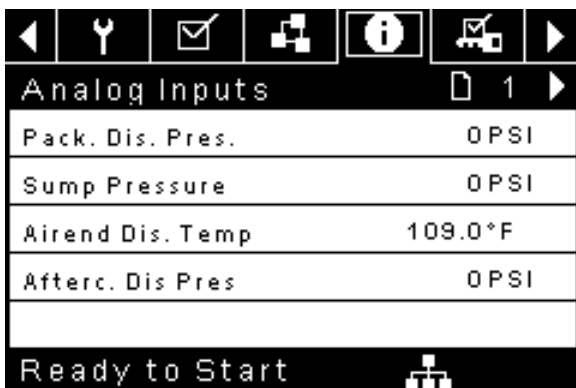

Analog Inputs	
Pack. Dis. Pres.	0 PSI
Sump Pressure	0 PSI
Airend Dis. Temp	109.0°F
Afterc. Dis Pres	0 PSI

Ready to Start

The following analog inputs are displayed in this section:

- **Package Discharge Pressure** - The pressure the compressor is delivering to the plant.
- **Sump Pressure** - The compressor's internal pressure at the sump tank.

- **Airend Discharge Temperature** - The temperature of the air/oil mixture at the discharge of the compression module.
- **Aftercooler Discharge Temperature** - The temperature of the air after passing through the Aftercooler. *Note that this will only be shown if the Low Ambient option has been purchased and installed.*
- **Aftercooler Discharge Pressure (integrated dryer units only)** - Pressure the compressor is delivering before the dryer.
- **Separator Pressure Drop** - The pressure drop across the separator element.

Page 2: Compressor Data

Timers	
Running	67 hrs
Loaded	67 hrs
Power On	575 hrs
Time	14:40
Ready to Start	

The following information is displayed in this section:

- **Power On Hours** - The number of hours the controller has been powered up

- **Running Hours** - The number of hours the compressor's motor has been running
- **Loaded Hours** - The number of hours the compressor has been producing air
- **Real Time Clock** - Current time of day

Pages 3 & 4: Digital Inputs

The image displays two screenshots of a control panel interface, showing digital input settings for pages 3 and 4.

Page 3: Digital Inputs

Emergency stop	Closed
Main/Fan M. Over	Closed
REM load enable	Open
REM load/unload	Open

Ready to Start

Page 4: Digital Inputs

Remote Start	Open
Remote Stop	Closed
DI Dryer freeze	Open
Dryer high press	Closed

Ready to Start

Each digital input will have an indication showing whether the input is in an “OPEN” or “CLOSED” state. This is the physical state of the input and may not necessarily line up with the logical condition. The normal state is shown in the table below.

The following digital inputs are displayed in this section:

- **Emergency Stop** - Normally Closed
- **Main/Fan Motor Overload** - Normally Closed
- **Remote Load Enable** - Normally Open
- **Remote Load/Unload** - Normally Open
- **Remote Start** - Normally Open
- **Remote Stop** - Normally Closed
- **Dryer Temperature Fault** - Normally Open
- **Dryer High Pressure** - Normally Closed

Pages 5 & 6: Digital Outputs

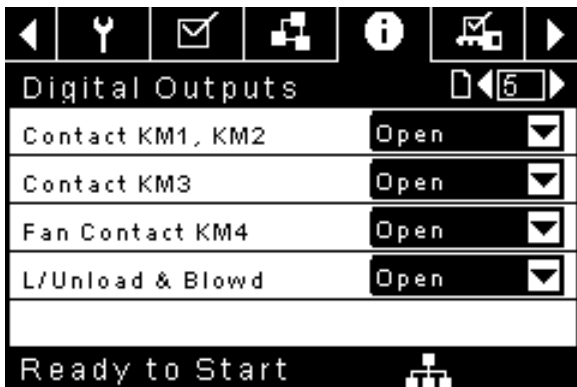

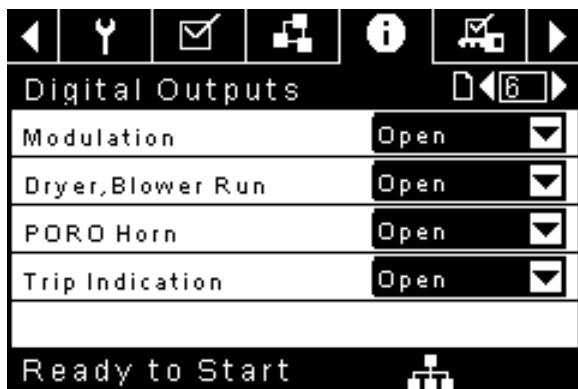

Each digital output will have an indication showing whether the output is in an “OPEN” or “CLOSED” state. This is the physical state of the input and may not necessarily line up with the logical condition.

The normal state is shown in the list below:

- **Starter Contact KM1, KM2** - Normally Open
- **Starter Contact KM3** - Normally Open
- **Fan Starter Contact KM4** - Normally Open
- **Load Solenoid 1SV** - Normally Open
- **Modulation Solenoid 3SV** - Normally Open
- **Dryer Run / Fan Run** - Normally Open
- **PORO Horn** - Normally Open
- **Trip Indication** - Normally Open

Page 7: Analog Outputs

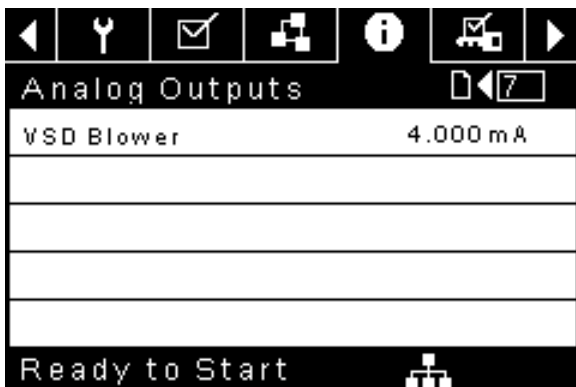

Analog Outputs	
VSD Blower	4.000 mA

Ready to Start

The value for the analog outputs will be in mA:

- **VSD Blower Output** - Current speed of the
- VSD blower (if installed)

Page 8: CT Inputs

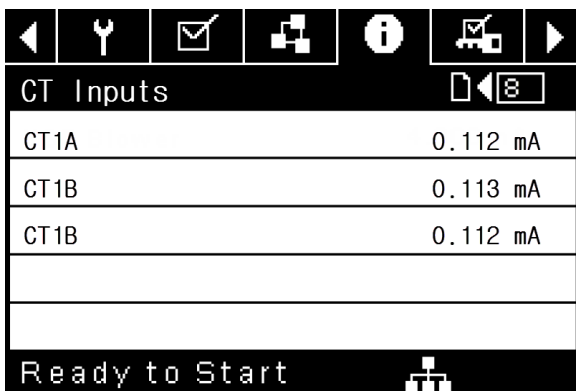

CT Inputs	
CT1A	0.112 mA
CT1B	0.113 mA
CT1B	0.112 mA

Ready to Start

Displays the mA value of the current transformers installed on each leg of the motor incoming power:

- CT1
- CT2
- CT3

Factory Settings Folder

This folder is for IR factory and service personnel. The password “2010” must be entered on page one in order to adjust values in this folder. This folder is used for setting parameters that are specific to that compressor and displaying software information for the controller.

Page 1: Password

Password	
Password	****
Password entered	<input checked="" type="checkbox"/>
Password Timeout	<input type="checkbox"/>
Pas. Timeout Del	10 SEC
Ready to Start	

Password - Provides access to enter a valid password to gain access to password protected parameters. The password is entered by scrolling down to the password value and pressing the return key.

Password entered - This checkbox will indicate a valid password has been entered. If this checkbox is blank, a

valid password has not been entered or it has timed out. This is read only.

Password timeout enable - Checking this box will enable the password time feature.

Password timeout - This timeout along with the password timeout enable allows the user to set an adjustable amount of time to require a valid password to be re-entered. Once this timeout is reached re-entry of a valid password is required. The timeout counter is reset after any button press.

Pages 2 - 6: Factory Setpoint

These pages are used for setting parameters that are specific to the compressor. All of the factory settings that are adjustable are listed below. All settings on these pages are password protected (2010).

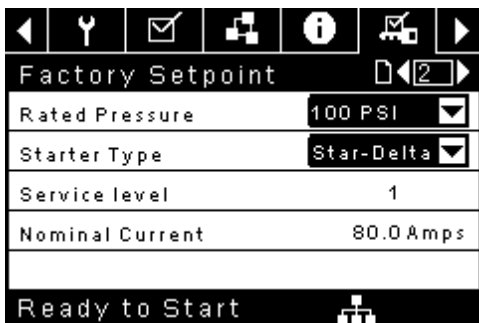

Factory Options						3
En. Modulation						<input type="checkbox"/>
Enable PAC						<input checked="" type="checkbox"/>
Enable Dryer						<input checked="" type="checkbox"/>
Const Run. Dryer						<input checked="" type="checkbox"/>
Ready to Start						
Factory Options						4
En. VSD Blower						<input type="checkbox"/>
Limit VSD Blower						<input checked="" type="checkbox"/>
Enable Low Amb.						<input type="checkbox"/>
Ready to Start						
Hours Adjustment						5
Running						67 hrs
Loaded						67 hrs
Power On						575 hrs
Ready to Start						

Rated Pressure (psi - 100, 115, 135, 190) - This is the nominal pressure that the compressor can provide.

Starter Type (Star-delta, Remote Starter, Soft Starter) -

Choose the starter type installed in the compressor. If this is not set correctly, the compressor may not start.

Service Level (0, 1, or 2) - Set the service level reminders for the compressor.

- **Service Level 0** - Disables all service reminders.
- **Service Level 1** - A service warning will be issued when the service time period has been expired. This warning can be reset by any user.
- **Service Level 2** - A service warning will be issued 100 hours prior to the service time period expiring. This 100 hour warning can be reset by any user. At the expiration of the service time interval the service warning will again occur. This warning can be reset by any user but will recur every 24 hours until the service complete factory setpoint has been set (Password Required).

Nominal Current - Used to set up the motor overload protection. This value must match the nameplate nominal current from the main motor.

Motor Protection - Used to enable current transformer based overload and locked rotor protection. This must be set to ON unless a thermal overload is installed in the compressor starter panel.

Main Motor CT Range - Must match the range of the installed current transformers. All current transformers must have the same range.

CT Windings - Must match the number of windings of the installed current transformers. All current transformers must have the same winding number.

Enable Modulation (On/Off) - This enables the modulation option in the controller, allowing Modulation or Mod/ACS modes of operations to be chosen from the operator settings. The modulation option must be installed on the compressor for this to work.

Enable PAC (On/Off) - Enables Progressive Adaptive Control - this will reduce operating pressure in the case of a Change HE Filter warning or High Sump Pressure warning in order to protect the compressor.

Enable Dryer (On/Off) - Enables dryer control from the controller. The dryer option must be installed in the compressor for this to work properly.

Constant Run Dryer (On/Off) - Enabling this function causes the dryer to run whenever the compressor is in a running state, including auto-restart. Disabling this will allow the dryer to stop if certain conditions are met, such as satisfying a minimum run timer. Certain dryer warnings will stop the dryer regardless of this setpoint. If the dryer stops for any reason it will not be allowed to restart for 90 seconds. When the compressor is being controlled by an external source, constant run dryer will be enabled regardless of this setpoint's state.

Enable VSD Blower (On/Off) - Enable this function if there is a VSD blower option installed in the compressor.

Limit Blower VSD (On/Off) - Enable this setpoint to limit the maximum speed of the blower to 39 Hz.

Enable Low Ambient (On/Off) - Enable this setpoint to activate low ambient control. Low ambient control uses temperature readings to determine the speed of the blower to allow the compressor to reach an optimal operating temperature. When low ambient is enabled, the compressor will always start, but will run unloaded until the airoend discharge temperature reaches the low ambient temperature set point.

Running Hours (adjustable) - Used to adjust the running hours counter on the compressor.

Loaded Hours (adjustable) - Used to adjust the loaded hours on the compressor.

Power On Hours (Read Only)

Pages 7 - 8: Software Version



The screenshot shows a control panel interface with a top navigation bar containing icons for back, wrench, checkmark, server rack, information, printer, and forward. Below this is a title bar for 'Software Version' with a page indicator '6'. The main content area is a table with four rows of software information. The bottom of the screen shows 'Ready to Start' and a server rack icon.

Software Version	
Software name	Q1MCMCIR
Software Rev	E13
Software name QL	QLCMCWA1
Software rev QL	E01

Ready to Start

These pages are used for displaying software information for the controller. All items are read only.

Connection to the MODBUS Network

The Xe-70M controller is designed to interface to any MODBUS RTU master capable device using Belden 9841 or equivalent RS-485 cable. In order to connect to the network, the cable must be connected to port X04 on the controller as shown below:

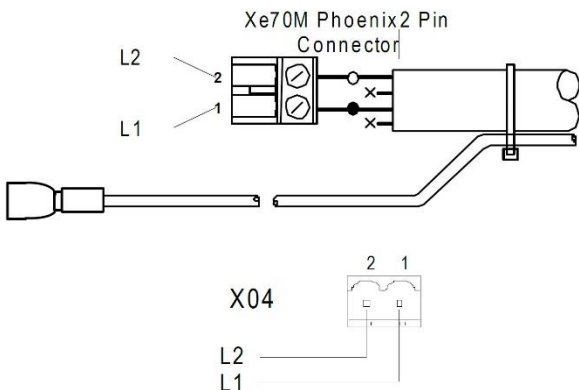

RS-485 Network

RS-485 data communications and other low voltage signals can be subject to electrical interference. This potential can result in intermittent malfunction or anomaly that is difficult to diagnose. To avoid this possibility always use earth shielded cables, securely bonded to a known good earth at one end. In addition, give careful consideration to cable routing during installation:

1. Never route an RS-485 data communications or low voltage signal cable alongside a high voltage 3- phase power supply cable. If it is necessary to cross the path of a power supply cable(s), always cross at a right angle.
2. If it is necessary to follow the route of power supply cables for a short distance (for example: from a compressor unit to a wall along a suspended cable tray)

attach the RS-485 or signal cable on the outside of an earthed cable tray such that the cable tray forms an earthed electrical interference shield.

3. Where possible, never route an RS-485 or signal cable near to equipment or devices that may be a source of electrical interference (for example: 3-phase power supply transformer, high voltage switchgear unit, frequency inverter drive module, radio communications antenna).

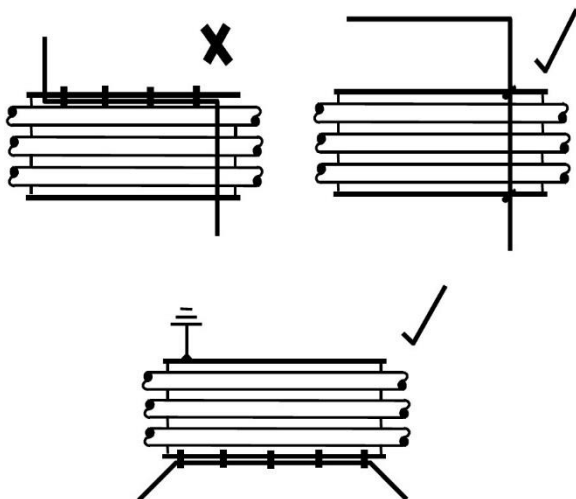

MODBUS Address Selection

Each compressor connected to the MODBUS network will have a unique assigned address, starting at compressor 1 increasing sequentially to the number of compressors connected to the MODBUS network.

The MODBUS address for each compressor is set on the General Settings Tab, Page 4. The controller's default MODBUS Address setting is 1.

Additionally, the active protocol must be set to MODBUS Slave.

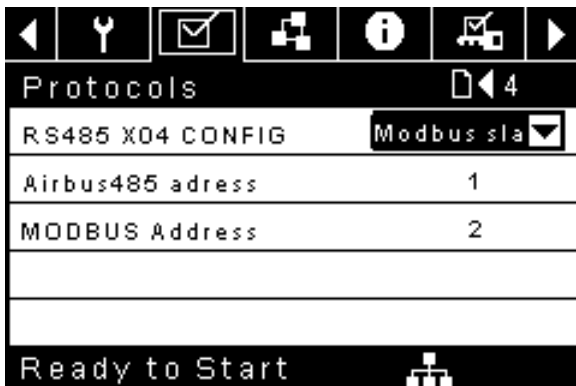

MODBUS Master Settings

In order to communicate properly with the Xe-70M controller, the MODBUS master must be set to communicate with the following configuration:

Baud Rate - 9600

Data Bits - 8

Stop Bits - 1

Parity - None

The following polling parameters are recommended for optimal system operation:

Polling Rate: Not less than 500 ms

Timeout: 500 ms

Retries: 2

SUPPLEMENTAL MATERIAL CONTENTS

TOPIC	PAGE
Wiring Schematics	83
UP6S 15-30HP / UP5S 11-22KW	84
Xe-70M Fixed Speed - Star Delta	
R5.5-11kW Fixed Speed - Star Delta	85
R30-37 Fixed Speed - Star Delta	86
RS30-37ie Fixed Speed - Star Delta	87
Tables	91
Table 8: R4-37kW Fixed Speed MODBUS Table	91
Table 9: Fixed Speed Register 01-Status/Control	92
Table 10: Fixed Speed Register Codes	92
Table 11: Fixed Speed Trip & Warning Codes	93
X-Series System Controls Connection	94
RS-485 Network	94
RS-485 Address Selection	96
Enabling System Control Capabilities	96

Wiring Schematics

The following wiring schematics are provided for reference and example purposes only. Some terminations may not be shown or may be incorrect for your application. Always refer to the wiring schematics and drawings specific to your compressor for the most accurate information.

List of Schematics and Drawings:

UP6S 15-30HP / UP5S 11-22KW Xe-70M Fixed Speed - Star Delta (48775233 Rev E)

R5.5-11kW Fixed Speed - Star Delta (24437683 Rev E)

RS30-37i Fixed Speed - Star Delta (24276602 Rev L)

RS30-37ie Fixed Speed - Star Delta (49107048 Rev E)

RS30-37ie Fixed Speed - Star Delta (49107048 Rev E) - Controller P1-P4

SCHEMATIC ELECTRICAL WINDING (S.E.W.)

 49107048

 SHEET 2 OF 5

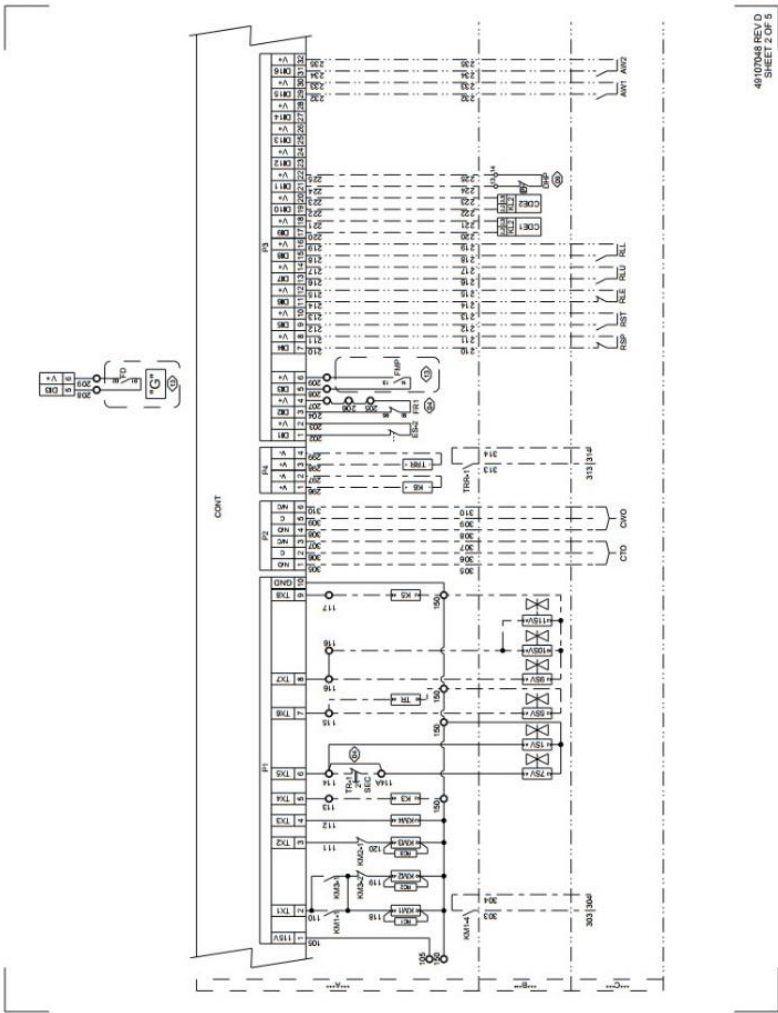

49107048 REV D
SHEET 2 OF 5

RS30-37ie Fixed Speed - Star Delta (49107048 Rev E) - Legend

LEGEND		LEGEND	
LABEL	DESCRIPTION	LABEL	DESCRIPTION
0V	ZERO VOLTAGE	RTD7	MOTOR DE BEARING RTD
1A1T	PACKAGE INLET TEMPERATURE	RTD8	MOTOR NDE BEARING RTD
1AVPT	INLET VACUUM PRESSURE	RTDMON	MOTOR RTD MONITOR
1P1	DRYER SAFETY PRESSURE SWITCH	SSH	STARTER SPACE HEATER
1P2	DRYER FAN PRESSURE SWITCH	T1	CONTROL POWER TRANSFORMER
1Q1	DRYER COMPRESSOR MOTOR OVERLOAD	TH	THERMOSTAT
1Q2	DRYER FAN MOTOR OVERLOAD	TR	TIMING RELAY
1SV	LOAD VALVE	TRM	POWER TERMINAL
1SVT	1SV HEAT TRACE	TRR	COMPRESSOR RUNNING LOADED RELAY
1T1	DRYER CONTROL POWER TRANSFORMER	ZNR	ZENER DIODE
1T2	DRYER FAN 1M2 THERMAL SWITCH		
2APT	INTERSTAGE PRESSURE		
2ATT	AIREND DISCHARGE TEMPERATURE		
2CTT	INJECTED COOLANT TEMPERATURE		
3APT	SUMP PRESSURE		
3ATS	AMBIENT TEMP THERMOSTAT		
4APT	PACKAGE DISCHARGE PRESSURE		
4ATT	AFTERCOOLER DISCHARGE TEMP.		
4SV	WATER SHUT OFF VALVE (W/C ONLY)		
5CPT	COOLANT FILTER INLET PRESSURE		
5DTT	DRYER EVAPORATOR TEMPERATURE		
5SV	MODULATION VALVE		
6CPT	COOLANT FILTER OUTLET PRESSURE		
6DTT	DRYER CONDENSER TEMPERATURE		
7APT	AFTERCOOLER DISCHARGE PRESSURE		
7SV	LOAD VALVE ISOLATION		
9SV	CONDENSATE SOLENOID VALVE		
10APT	REMOTE PRESSURE		
10SV	CONDENSATE SOLENOID VALVE		
11SV	CONDENSATE SOLENOID VALVE		
AT1	AUTO TRANSFORMER		
AW1	AUXILIARY WARNING 1		
AW2	AUXILIARY WARNING 2		
BLH	BASE LEVEL HEATER		
BP	BACKPANEL		
CAB	CABINET		
CAP	CAPACITOR		
CDEx	CONDENSATE DRAIN ERROR		
CDVx	CONDENSATE DRAIN VALVE		
CONT	Xe CONTROLLER		
CTO	COMMON TRIP OUTPUT		
CWO	COMMON WARNING OUTPUT		
DHP	DRYER HIGH PRESSURE		
DMH	DRIVE MOTOR HEATER		
DTW	DRYER TEMPERATURE WARNING		
EB	EARTHING BAR		
ES	EMERGENCY STOP BUTTON		
FD	FAN DRIVE		
FM	FAN MOTOR		
FMH	FAN MOTOR HEATER		
FMP	FAN MOTOR PROTECTOR		
FR1	MAIN MOTOR OVERLOAD		
Fx	DRYER FUSES		
FUx	FUSES		
IVH	INLET VALVE HEATER		
K2	PHASE MONITOR RELAY		
K3	BLOWER DRIVE CONTROL RELAY		
K4	LOW AMBIENT CONTROL RELAY		
K5	DRYER RUN INDICATION RELAY		
K6	PORO RELAY		
KM1	MAIN CONTACTOR		
KM2	DELTA CONTACTOR		
KM3	START CONTACTOR		
KM4	COOLING FAN MOTOR CONTACTOR		
KM5	DRYER COMPRESSOR CONTACTOR		
KM6	DRYER FAN CONTACTOR		
MCBx	CIRCUIT BREAKERS		
MM	MAIN MOTOR		
MSHT	MOISTURE SEPARATOR HEAT TRACE		
OSH	OIL SUMP HEATER		
PE	PROTECTED EARTH		
PORO	POWER OUTAGE RESTART OPTION		
PSU	POWER SUPPLY UNIT		
R1	DRYER CONTROL RELAY		
RCx	ARC SUPPRESSOR		
RE	REMOTE LOAD ENABLE		
RL	REMOTE LEAD LAG		
RLU	REMOTE LOAD/UNLOAD		
RSP	REMOTE STOP		
RST	REMOTE START		
RTD1-6	MOTOR WINDING RTD		

Table 8: R4 - 37kW Fixed Speed MODBUS Table

Register (40XX)	Variable	Read/Write	Range	Notes
1	Status/Control	R/W		See table 9
3	Package Discharge Pressure	R		
4	Sump Pressure	R		
7	Airend Discharge Temperature	R		
8	After-cooler Discharge Temperature	R		Low ambient units only
10	Separator Pressure Drop	R		
16	After-cooler Discharge Pressure	R		Dryer units only
65	Running Hours MSB	R		
66	Running Hours LSB	R		
67	Loaded Hours MSB	R		
68	Loaded Hours LSB	R		
98	Rated Pressure	R		
100	Starter Type	R	1 - 3	See table 10
101	Modulation Enabled	R		0 = Disabled
102	Service Level	R	0 - 2	0 = Level 0, 1 = Level 1, 2 = Level 2
103	Service Time Period	R	1000 - 8000	Increments of 1000
104	Dryer Installed	R		0 = OFF
112	Offline Pressure	R/W	75 - (rated+10)	Rated = Rated pressure
113	Online Pressure	R/W	65 - (rated+10)	Offline = Offline pressure
114	Mode of Operation	R/W	0 - 2	See table 9
115	Starter Time (seconds)	R/W	5 - 30	
116	Auto Restart Time (seconds)	R/W	110 - 3600	
117	Auto Restart ON/OFF	R		0 = OFF
118	Communication Control ON/OFF	R		0 = OFF
119	Remote Start/Stop Enable	R		0 = OFF
121	Power Out Restart Option (PORO) Enable	R		0 = OFF
122	PORO Time (seconds)	R/W	10 - 600	
123	Auto Start/Stop Delay Time (seconds)	R/W	0 - 60	
124	Low Ambient Temperature	R/W	30 - 60	Degree F
125	Unloaded Stop Time	R/W	10 - 30	
128	Lead/Lag	R/W		0 = Lag
129	Lead Offset	R/W	0 - 45	Psi
131	Lead/Lag Cycle Length (hours)	R/W	0 - 750	
132	Scheduled Start (Day)	R/W	0 - 9	See table 10
133	Scheduled Start (Hour)	R/W	0 - 23	
134	Scheduled Start (Minute)	R/W	0 - 59	
135	Scheduled Stop (Day)	R/W	0 - 9	See table 10
136	Scheduled Stop (Hour)	R/W	0 - 23	
137	Scheduled Stop (Minute)	R/W	0 - 59	
255	Warning Code	R		See table 11
256	Trip Code	R		See table 11
400	Reset Web Logins	R/W	0 - 1	Writing a 1 value will reset the web logins to factory defaults. After the reset is performed this value shall be set back to 0.

Table 9: Xe-70M Fixed Speed Controller Register 01 - Status/Control

<p>Bit 0: Host/Local (R/W)</p> <p>0 = Local 1 = Host</p> <p>Bit 1: Run/Stop (R/W)</p> <p>0 = Stop 1 = Run</p> <p>Bit 2: Load/Unload (R/W)</p> <p>0 = Unload 1 = Load</p> <p>Bit 3: Modulating (R) **</p> <p>0 = Not Modulating 1 = Modulating</p> <p>Bit 4: Unused</p> <p>Bit 5: Stopped in Auto Restart (R)</p> <p>0 = Not Stopped in Auto Restart 1 = Stopped in Auto Restart</p>	<p>Bit 6: Alarm (R)</p> <p>0 = No Alarms 1 = Alarms</p> <p>Bit 7: Warning (R)</p> <p>0 = No Warnings 1 = Warnings</p> <p>Bit 8: On/Off Line Mode (R)</p> <p>0 = Not in On/Off Line Mode 1 = On/Off Line Mode</p> <p>Bit 9: Mod/ACS or Mod Only (R) **</p> <p>0 = Not in Mod/ASC Mode 1 = Mod/ASC Mode</p> <p>Bits 10-12: Unused</p> <p>Bits 13-15: Unit Type (R): Unused</p>
---	--

Table 10 : Xe-70M Fixed Speed Controller Register Codes

<p>Register 100: Starter Type</p> <p>1 = Star-Delta</p> <p>2 = Remote Starter</p> <p>3 = Soft Starter</p>	<p>Register 114: Mode of Operation</p> <p>0 = On/Off Line</p> <p>1 = MOD/ACS **</p> <p>2 = Modulation Only **</p>
<p>Registers 132, 135: Day</p>	
<p>0 = Sunday</p> <p>1 = Monday</p> <p>2 = Tuesday</p> <p>3 = Wednesday</p>	<p>4 = Thursday</p> <p>5 = Friday</p> <p>6 = Saturday</p>
	<p>7 = Daily</p> <p>8 = Weekdays</p> <p>9 = Weekends</p>

Table 11 : Xe-70M Fixed Speed Controller Trip & Warning Codes

Code	Description	Code	Description
02**	Sensor Failure 3APT	32	Emergency Stop
03	Sensor Failure 4APT	34**	Change Separator Element
08**	Sensor Failure 7APT	36	Sensor Error (Calibration)
10	Sensor Failure 2ATT	38	100 Hours To Service
11**	Sensor Failure 7ATT	39	Service Required
18	Motor Overload (Main) - due to CTs	40	Alarm - Service Required
19	Overload - due to Thermal OL	48	Unit Too Cold To Start
22**	Check Motor Rotation	49**	High Sump Pressure
25	Remote Stop Failure	51**	Dryer High Pressure
26	Remote Start Failure	52	Dryer Temperature Warning
28**	Low Sump Pressure	55	Change HE Filter (Dryer)
29	High Air Pressure	56	Sensor Failure - Main Motor CT Inputs
31	High Airend Discharge Temperature		

Note that () marked bits and codes are not applicable for R4-11 packages.**

X-Series System Controls Connection

The Xe-70M controller is designed to interface to an Ingersoll Rand X-Series System Controller using Belden 9841 or equivalent RS-485 cable. In order to connect to the network, the cable must be connected to port X04 on the controller as shown in the diagrams below. *Note that up to 8 (X8I) or 12 (X12I) devices can be daisy chained together in an X-Series network:*

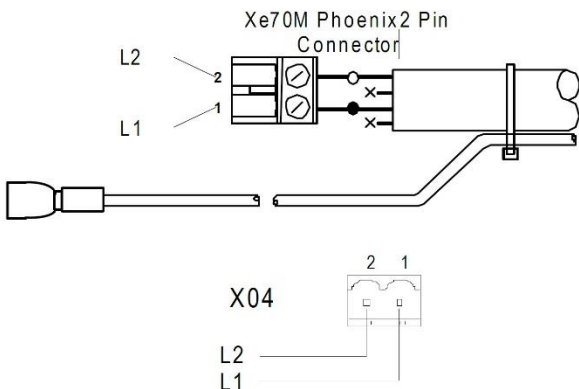

RS-485 Network

RS-485 data communications and other low voltage signals can be subject to electrical interference. This potential can result in intermittent malfunction or anomaly that is difficult to diagnose. To avoid this possibility always use earth shielded cables, securely bonded to a known good earth at one end. In addition, give careful consideration to cable routing during installation:

4. Never route an RS-485 data communications or low voltage signal cable alongside a high voltage 3-phase power supply cable. If it is necessary to cross the path of a power supply cable(s), always cross at a right angle.
5. If it is necessary to follow the route of power supply cables for a short distance (for example: from a compressor unit to a wall along a suspended cable tray)

attach the RS-485 or signal cable on the outside of an earthed cable tray such that the cable tray forms an earthed electrical interference shield.

Where possible, never route an RS-485 or signal cable near equipment or devices that may be a source of electrical interference (for example: 3-phase power supply transformer, high voltage switchgear unit, frequency inverter drive module, radio communications antenna).

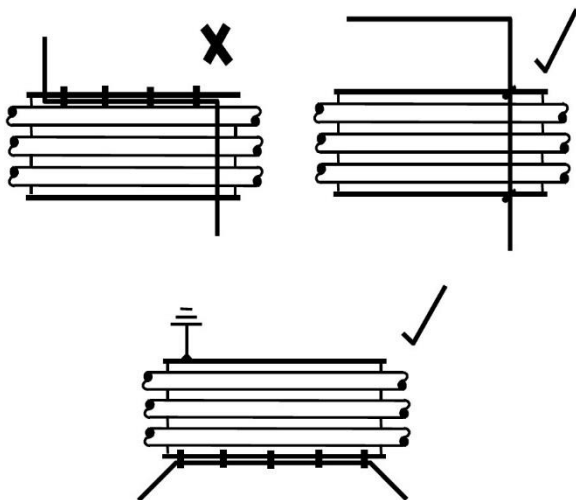

RS-485 Address Selection

Each compressor connected to the network will have a unique assigned address, starting at compressor 1 increasing sequentially to the number of compressors connected to the network.

The RS-485 address for each compressor is set on the General Settings Tab, Page 4. The controller's default RS-485 Address setting is 1.

Additionally, the active protocol must be set to Airbus485.

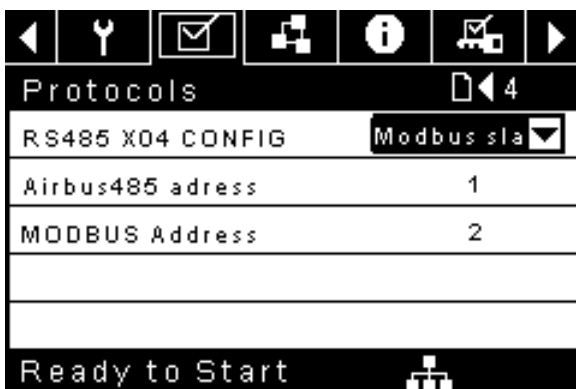

Enabling System Control Capabilities

In order to communicate properly with the X-Series system controller, the Xe-70M must have the following setpoints correctly set.

On the Operator Settings tab, page 3 (Fixed Speed) or page 2 (Variable Speed).

Verify that the COM control setpoint is enabled (Checkbox is filled in) as shown below. If this setpoint is not selected, the system controller will be unable to load or unload the machine.

Additionally, for fixed speed machines, make sure that the Enable Auto-Restart setpoint is enabled (checkbox is filled in) or the compressor will continue to run when unloaded by the system controller.



After the address and COM control have been set, be sure that Integral Sequencing is disabled by navigating to Integral Sequencing, page 1 and verifying that the Integral sequencing setpoint is disabled (checkbox not filled in) as shown below:

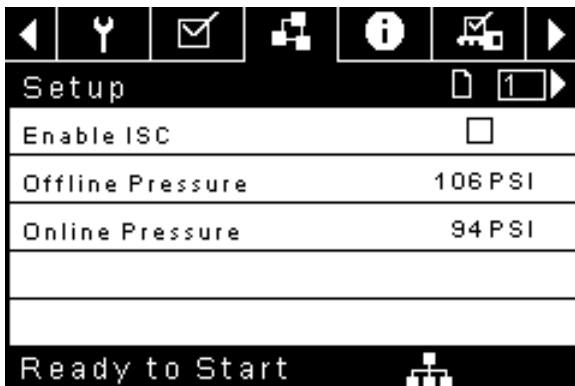

Once these setpoints are correctly set and the machine is started locally, the system controller should see status information from the compressor and be able to take control.

Change Log

April 2018: Initial Release

