

**S**implicity  
**S**erviceability  
**R**eliability



**MEDIUM INDUSTRIAL SYSTEMS**  
Davidson, North Carolina 28036

# **SE** **Control System**

## **Technicians Guide**

© Ingersoll-Rand 2000  
Printed in U.S.A.

Form APDD585D  
August 2000

# CONTENTS

TOPIC	PAGE NOS.
SSR MODEL SE CONTROLLER INTRODUCTION .....	1
SSR MODEL SE CONTROLLER INPUT/OUTPUT INFORMATION .....	14
SSR MODEL SE CONTROLLER .....	15
INTELLISYS .....	17
SSR MODEL SE PANEL DISPLAY .....	18
SSR MODEL SE CONTROLLER MEMBRANE PAD ..	23
SSR MODEL SE CONTROLLER - HIDDEN BUTTON OPERATION .....	26
SSR MODEL SE AUTOMATIC START/STOP OPERATION .....	29
SSR MODEL SE ALARM SHUTDOWNS .....	33
SSR MODEL SE ROTATION CHECK AND LOW PRESSURE ALARM .....	43
SSR MODEL SE HIGH AIREND DISCHARGE TEMPERATURE WARNING AND ALARM .....	45
SCHEMATICS - FULL VOLTAGE .....	49
SCHEMATICS - STAR DELTA .....	54
ORDER FORM .....	59

## **SSR MODEL SE CONTROLLER INTRODUCTION**

The Intellisys control concept is an exclusive Ingersoll-Rand design developed expressly for reliable compressor control and monitoring of operation.

The microprocessor based system utilizes a finger touch membrane panel for all compressor control functions to include operating parameter settings and display information.

The operating status of the compressor is visible in a L.C.D. (Liquid Crystal Display) on the front of the controller.

The Intellisys continuously monitors the operation of the compressor and should any condition deviate from the pre-programmed limits, the controller will automatically display a warning or shut the compressor down if necessary.

Operation of the control system will be easy to understand after the following explanation of various control system components.

### **1FU and 2FU**

Identical fuses specially designed for control transformer protection and installed in each of the two wires connecting line voltage to the primary side of the transformer. These fuses provide a degree of protection should a short-circuit develop in the transformer.

These fuses have a time-delay feature to handle the short duration, but very high, inrush current when the transformer is first powered-up. For an instant at power-up, the inrush current drawn by the control voltage transformer can be several times the full-load rating.

1FU and 2FU are also current limiting to protect downstream components from damage and magnetic effects of short-circuit currents. Current limiting is defined as being able to cut off a short-circuit current in less than one-half cycle (.008 second, 60 Hz). Generally speaking, this is long before damaging levels are reached.

These particular fuses are listed as CC Class high performance and have a unique shaped cap on one end. The unique shape is designated as "R" for rejection and is made to fit into a corresponding shaped rejection type fuse clip that prevents slower response fuses from being installed.

### **T1 - Control Transformer**

Present production SE compressors use a multiple tap 330 VA transformer to step-down the incoming line voltage to lower levels as a power source for the Intellisys control system.

The reduced voltage levels are called secondary connections and there are two.

The first secondary circuit is rated at 120 volts AC and is basically used to energize solenoid valves and motor starter coils.

The other secondary circuit is 16 volts AC which is

regulated and converted to 5 volts DC for use by the Intellisys controller and various sensors.

A connection diagram for the possible primary voltages (575, 460, 230, 200) is included in the Operators/Instruction Manual. It is important that the transformer be connected properly or damage to the control system may result.

### **3/4/5FU**

Dual element fuses on the secondary side of the control transformer that provide a degree of protection to the Intellisys system.

Dual element fuses use two individual elements in series inside the fuse body.

One element, a spring actuated trigger assembly, operates on overloads up to 5-6 times the fuse current rating. When the overload has lasted long enough to melt a soldered area, the spring pulls the joint apart to break the circuit.

The other element, the short circuit section, operates on short circuits up to its interrupting rating.

### **1LT**

A "Power-On" indicator light located in the starter box area and wired to the 120 volt AC circuit. When incoming power has been applied to the control voltage transformer and 3FU is in good condition, 1LT will become lighted.

As the previous description indicates, a "Power-On" condition exists and care must be taken to

prevent injury or damage from contact with any part of the electrical circuit.

NEVER use an indicator light to confirm power has been turned off! A blown bulb or loose wire will give a false indication!

### **Emergency Stop Switch**

Located on the front of the compressor and intended to stop the compressor only in an emergency.

This switch has two sets of normally-closed contacts that open when the red button is pressed. Refer to the wiring schematic in the Operators/ Instruction Manual and observe one contact to be in the 120 volt AC power circuit and the other to be in the 5 volt DC logic circuit. These parallel contacts ensure power is removed from the starter and solenoids as well as the Intellisys controller to cause the compressor to stop immediately.

The switch will remain in the open condition until an operator manually resets the switch by rotating the red button clockwise.

### **1ATS**

This normally-closed switch monitors the discharge port of the airend and will open should the discharge temperature rise above 245 degrees Fahrenheit (118 degrees C.).

The mechanical switch serves as a back-up for the usual Intellisys temperature shutdown of 228 degrees Fahrenheit (109 degrees C.).

1ATS is connected in the 120 volt AC circuit and should it open, the Intellisys shuts the compressor down on an alarm condition and causes NO CONTROL POWER to appear in the message display.

The switch has SAE straight threads with an o-ring seal. The set point is not adjustable and the ceramic material on the wire end is blue in color for identification purposes.

### **2ATT**

A thermally sensitive resistor called a thermistor installed in the discharge port of the airend to monitor the temperature of the air/oil mixture leaving the airend.

The thermistor is made from a mixture of sintered metal oxides such as manganese, cobalt or nickel sealed within a glass bead and then placed in a stainless steel housing. Two wires are attached to the thermistor...a Black wire "in" and a White wire "out".

A constant 5 volts DC is applied to the Black wire and, as an example, at 228F. (109 degrees C.), the voltage allowed through the thermistor will be reduced to approximately 1.5 volts DC to ground. The resistance decreases as the temperature increases. As the temperature changes, either higher or lower, the output voltage will change a corresponding amount.

This varying DC voltage is processed by an Analog-To-Digital converter and forwarded to the Intellisys controller.

Depending on the output voltage, the Intellisys makes decisions that may only change a temperature number on the panel display or could possibly shut the compressor down if conditions dictate.

The thermistor housing has SAE straight threads with an o-ring seal. There is no adjustment capability and if replacement is required, disconnect the wires from the terminal strip and unscrew the housing from the airend.

There is a temperature/resistance chart in the Intellisys Serviceman's Guide APDD-422 that can be used to check the accuracy of the thermistor.

The Intellisys controller is programmed to shut the compressor down on an alarm when the airend discharge temperature exceeds 228F. (109 degrees C.) and show HIGH AIREND TEMP in the message display.

In addition, if the compressor has a HIGH AIREND TEMP alarm, the airend must cool below 217F. (103 degrees C.) before the Intellisys can be reset and the alarm cleared.

If an attempt is made to reset the alarm while the temperature is still above 217F., the Intellisys automatically adds "MUST COOL DOWN" to the message display which then alternates with any existing alarm messages.

### **3APT**

A pressure transducer used to convert an air pressure signal to an analog signal between 0 and 50 millivolts.

The transducer contains a metal diaphragm connected to a small piece of steel called the beam, which in turn has a strain gauge attached. As pressure pushes the diaphragm, the beam flexes and bends the strain gauge.

A continuous 5 volts DC supply is connected to the strain gauge assembly.

As the strain gauge bends due to the changing pressure on the diaphragm, the resistance value changes a corresponding amount. The result is a variable output signal that ranges from 0 millivolts at 0 psig to 50 millivolts at 200 psig.

The output signal is processed by an Analog-To-Digital converter and forwarded to the Intellisys controller. Depending on the voltage level, decisions are made by the Intellisys that may cause a change to the pressure reading on the display panel, unload the compressor or possibly shut the compressor down if conditions dictate.

There are no adjustments to 3APT and should a problem develop, it must be replaced.

To replace, disconnect the small cable at the top of the transducer by removing the center screw. Lift the cable up and off. Unscrew the transducer from the solenoid valve. Install the new transducer and replace the cable.

It is important to calibrate the transducer whenever a replacement has been made to either the transducer or the Intellisys controller.

Basically, calibration allows the Intellisys to read

the transducers output signal when the diaphragm is in a totally relaxed state and then correct for any minor deviations from 0 millivolts.

Calibration directions are included in the Operators/Instruction Manual.

### **10SV**

A normally open 3-way solenoid with pressure transducer 3APT connected to the common port. The valve is known schematically as 10SV and usually called the Line/Sump Solenoid. 10SV connects pressure transducer 3APT to either the Line or the Sump.

When de-energized, 10SV allows Line pressure to enter the pressure transducer via the normally-open port. The line pressure, if any, causes the transducer diaphragm to bend the strain gauge as described earlier and send a millivolt signal to the Intellisys which will react accordingly. The compressor may load, unload, etc.

When energized, 10SV connects transducer 3APT to the wet side of the sump (before the separator element) via the normally-closed port. The sump pressure, if any, causes the pressure transducer to respond and send millivolt information to the Intellisys controller.

It is very important to understand that these two pressure points, Line and Sump, are vital to the overall control logic.

Obviously, line pressure is of major interest to the Intellisys controller for loading and unloading the

compressor.

The sump pressure is also important for a variety of reasons. At start, presence of a small amount of sump pressure indicates correct direction of drive motor rotation and a higher after-starting sump pressure ensures adequate coolant/lubricant flow.

The Intellisys controller automatically energizes 10SV at start to confirm these pressures to be present during the check sequence. Should the correct pressures not be available, the Intellisys shuts the compressor down and displays the appropriate alarm message.

Sump pressure is also compared to line pressure when checking the separator element differential. 10SV, the Line/Sump solenoid, provides quick access to these two pressure points as the solenoid is energized and de-energized.

With few exceptions, 10SV is de-energized and connects 3APT to Package Discharge Pressure during normal compressor operation.

Should an operator select Sump Pressure with the Display Select button and then walk away from the compressor, the Intellisys will automatically return the display (by de-energizing 10SV) to Package Discharge Pressure after pre-selected Display Time has expired.

### **1SV**

A normally-open 3-way solenoid valve connected within the control system to direct pressurized air into, or allow it to vent out of, the aircend inlet

unloader valve. The flow of pressurized air into, or out of, the unloader valve causes the valve to open or close and thereby load or unload the compressor.

The solenoid valve is known schematically as 1SV, has a 120 volt AC coil and is usually called the Unload Solenoid.

Inside the solenoid is a steel plunger held in position by a spring. When the coil is de-energized, the spring maintains the plunger such that pressurized air can flow freely in either direction through the common and normally-open ports of the valve. The normally-closed port is closed at this time.

When the valve is energized by applying 120 volts AC to the coil, an electro-magnetic field is created that causes the steel plunger to overcome the spring as the plunger is drawn to the magnet. As the plunger shifts positions, the internal port connections are changed.

Pressurized air can now flow in either direction through the common and normally-closed ports. At this time, the normally- open port is closed.

When the solenoid valve is later de-energized by removing the 120 volts AC from the coil, the magnetic effect disappears and the spring pushes the plunger back to its original position.

Although 1SV rarely has a problem, the valve can be taken apart should cleaning or inspection be required.

Always identify the marked ports of the valve to

insure the nylon tubing is reconnected properly. Refer to the piping schematic in the Operators/ Instruction Manual if required.

### **2SV**

A 2-way solenoid valve that allows pressurized air to pass through only when the 120 volt AC coil is energized.

The valve is simple in operation and basically consists of a steel plunger and a spring to hold the plunger in the normally-closed position.

When the coil is energized, a magnetic effect is created that lifts the plunger to open the valve. If the coil is de-energized, the spring forces the plunger back to the original closed position.

This valve is called the Modulate Solenoid and is energized only when Modulation or Mod/ACS has been activated on the Intellisys panel.

Air that passes through 2SV continues on to the Modulator Valve.

Refer to the Basic Flow Schematic in the Operators/Instruction Manual if required.

### **3SV**

3SV is the schematic designation for the Blowdown Solenoid.

When the compressor is unloaded or stopped, the normally-open 3SV is de-energized and releases sump pressure.

The valve is mounted directly in the air piping near the cover of the separator tank but prior to the combination minimum pressure/check valve.

The exhaust port is connected to the inlet filter housing to reduce noise as the pressurized air vents plus contain any lubricant vapors within the compressor.

When the compressor is stopped for reasons such as pushing the Unloaded Stop button, an Intellisys alarm or power failure, 3SV automatically releases internal pressure. Thereby, 3SV removes the danger of pressure remaining within the sump should the coolant/lubricant fill cap be removed or other work performed.

**Important:** It is good safety practice to always confirm internal pressure has been released prior to removing any caps, plugs, filters, etc.

### **6SV**

6SV is a 3-way modulation control solenoid used only on SE units equipped with Star-Delta starters. The valve is piped normally-open and works with, and is an assistant to, the previously described modulation solenoid 2SV.

Again, 6SV is used only on Star-Delta systems and results from the normally-closed inlet valve required on reduced torque starting systems.

Modulation solenoid 6SV has a coil rated at 120 volts AC which creates an electro-magnet when energized. The magnet lifts a steel plunger against a spring to cause the valve to operate. 6SV is

wired parallel with 2SV and both valves become energized (or de-energized) at the same time. Refer to both the electrical and piping schematics if required.

The requirement for the normally-closed inlet valve will be discussed during the Regulation section.

### **1M/1S/2M**

#### **1M/1S/2M**

An electrical schematic designation for the magnetic contactor that connects, or disconnects, an electrical supply for the compressor and cooling fan motors. Refer to the Electrical Schematic in the Operators/Instruction Manual.

The contactor closes to apply power to the motors when 120 volts AC is applied to the contactor holding coil. As 120 volts is applied, an electro-magnet field is generated by an iron core located within the holding coil. The magnetic field attracts a movable armature that, as the armature is drawn toward the iron core, connects power to the motors by closing a switch on each of the three phases.

When the 120 volt circuit is removed from the holding coil, the magnetic field no longer exists and internal springs return the contactor to the normally-open position. The motor stops at this time.

The contactor has a base and barriers to isolate each of the three phases. Upon opening or closing, these barriers also serve to contain the arc drawn across the contacts. The arcing is similar to the arcing associated with an electric welder.

## SSR MODEL SE CONTROLLER INPUT/OUTPUT INFORMATION

### DESIGNATED ANALOG INPUTS

Pressure transducer (3APT) that reads both  
line and sump pressure.  
Airend discharge temperature sensor (2ATT)

### DESIGNATED SWITCHED DIGITAL INPUTS

Drive motor overload relay (10L)  
Fan motor overload relay (20L)  
Starter Interlock (1Ma)  
Star-Delta Interlocks (1Sa & 2Ma)  
Remote Start  
Remote Stop  
Emergency Stop

### TRIAC OUTPUTS

Contactors coil (1M)  
Contactors coil (1S)  
Contactors coil (2M)  
Parallel solenoid coils (1SV & 3SV)  
Parallel solenoid coils (2SV & 6SV)  
Line/Sump solenoid (10SV)

### VOLTAGE FREE CONTACT

Common Alarm if PORO is not active  
PORO horn if PORO is active  
Rated 5A/250 Volts AC

## SSR MODEL SE CONTROLLER

### DISPLAY STANDARDS

Package Discharge Pressure  
Airend Discharge Temperature  
Sump Pressure  
Separator Pressure Drop  
Total Hours  
Loaded Hours

### MEMBRANE TOUCH PANEL

Start  
Unloaded Stop  
Display Select  
Up/Down Arrows  
Unloaded/Load  
Set (Reset)  
Hidden Left  
Hidden Right

### ADJUSTABLE OPERATING PARAMETERS

Off-Line Pressure  
On-Line Pressure  
Modulation/ACS  
On-Line/Off-Line  
Modulation Only  
Display Time  
Star-Delta Timer If Supplied  
Lead/Lag  
Lag Offset  
Low Ambient

### Option Selection

Auto S/S - On/Off  
Auto S/S Timer  
Sequencer - On/Off  
Remote S/S - On/Off  
PORO - On/Off  
Delay - To - Start Time  
Delay - To - Load Time

**INITIAL CHECK ALARM**

High Airend Temperature

**WARNING INDICATIONS**

High Airend Discharge Temperature  
Change Separator Element

**ALARM SHUTDOWNS**

Low Sump Pressure  
High Air Pressure  
High Airend Temperature  
Starter Fault  
Main Motor Overload  
Fan Motor Overload  
Remote Stop Failure  
Temperature Sensor Failure  
Remote Start Failure  
Check Motor Rotation  
Calibration Failure  
No Control Power  
Pressure Sensor Failure  
Emergency Stop

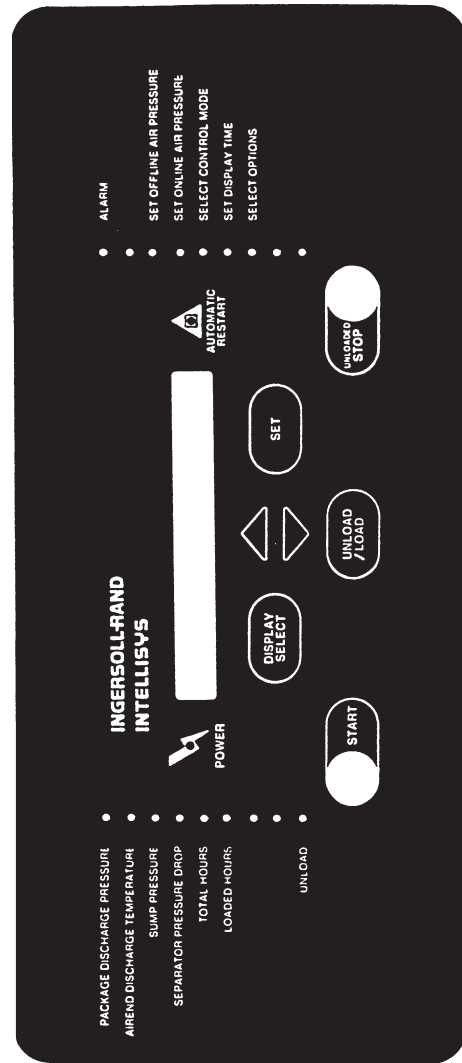

## **SSR MODEL SE PANEL DISPLAY**

### **NORMAL DISPLAY - NOT RUNNING**

The normal display message when the compressor is not running will be Ready To Start. However, if the Remote Start/Stop feature is enabled, the message will read Start Local/Remote. Neither message will be displayed if an Alarm condition exists.

### **NORMAL DISPLAY - RUNNING**

The normal display when a unit is running will be the current line pressure value and units of measure. As an example: 102 PSI. The green LED beside Package Discharge Pressure will be on.

### **DISPLAY SELECT OPERATION**

The operator can press the Display Select button and scroll through the following listed values. If the Display Select button is pressed to observe any value other than Package Discharge Pressure and then not pressed again within the period of time selected in the Display Time set point, the display returns automatically to the normal display selection. The display time is selectable between 10 and 600 seconds and is part of the customer set-point routine.

Remember: the "normal display" is Ready to Start or Start Local/Remote when the compressor is not running and Package Discharge Pressure when in operation.

## **PACKAGE DISCHARGE PRESSURE**

This is the normal display when the compressor is running; the green LED will be on and the display will show the current value of the Package Discharge Pressure and unit of measure. Pressure sensor 3APT provides the information.

### **AIREND DISCHARGE TEMPERATURE**

The Airend Discharge Temperature LED will be on and the display will show the current value of the temperature and the units of measure. Temperature sensor 2ATT is installed within the airend discharge port and provides this information to the controller. An example would be "207 DEG F".

### **SUMP PRESSURE**

When Sump Pressure has been selected, the green LED will be on, the Line/Sump solenoid 10SV will be energized and the display will show the current sump pressure and unit of measure. The sump is constantly scanned as long as the compressor remains loaded or manually unloaded.

The controller understands pressure sensor 3APT is connected to the sump and when loaded must make an adjustment to ensure the unit unloads at, or very near, the original Off-Line setting that is associated with the customers air pressure.

To do this, the controller automatically makes a calculation and unloads the compressor when the sump pressure is 5PSI plus the separator pressure drop above the Off-Line setting.

An important point...the controller makes an automatic 2 second check of the separator differential every loaded hour and stores the information to use during the above calculation. When the check is made, the line pressure must be above 90 PSI, the unit loaded and the line pressure may only change 2 PSI during the check. Should any of the parameters be out of range during the check, the controller continues checking until a reading is obtained. Once a reading is obtained and in the memory, the controller waits for another loaded hour before updating the information.

When the compressor unloads and Sump Pressure remains selected, the Line/Sump solenoid 10SV alternates every 15 seconds between Line and Sump. The Line is read for 13 seconds and the Sump for 2 and the Sump pressure is updated on the display after each 2 second check.

There is no display concerning line pressure at this time because Sump Pressure has been selected. However, the controller is aware because it reads the line pressure as the Line/Sump solenoid alternates back and forth. The controller reloads the compressor when the customer's air pressure falls to the On-Line Setting. Remember: the Sump Pressure reading will automatically return to Package Discharge Pressure at the end of the pre-selected Display time.

### **SEPARATOR PRESSURE DROP**

This check is made by the Intellisys once every loaded hour and stored in the memory or can be selected on the Display by an operator.

When an operator selects Separator Pressure Drop on the display, the check is made every 15 seconds. The actual check takes 2 seconds and 10SV will be energized during this time as the solenoid alternates between Line and Sump.

If the differential is 3 PSI or less, the controller will display 3 PSI.

If the differential is greater than 15 PSI, the controller will display 15 PSI.

The display will show RUN COMP TO CK, LOAD COMP TO CK or WAIT - LOADING if the compressor has not been running loaded for at least 8 seconds when this display is selected.

A warning feature is associated with the Separator Pressure Drop and will cause the message "Change Separator Element" to appear in the display if the following conditions occur.

Every loaded hour, the Intellisys automatically checks the separator differential to determine that the unit is at full load, not modulating, the line pressure is above 90 PSI and stable within 2 PSI during the 2 second check.

If the Intellisys calculation is greater than 12 PSI, the warning message "Change Separator Element" will appear in the display and the red Alarm LED will begin to flash. The compressor continues to run and deliver air to the customers system.

### **RUNNING HOURS**

The green LED will be on and the total number of

hours the compressor has run will be in the display. If the unit has operated less than 1 hour, the display will show minutes.

This information has value for scheduling maintenance.

### **LOADED HOURS**

The green LED will be on and the number of hours the compressor has been in a loaded condition will be in the display. If the unit has been loaded less than one hour, the display will show minutes.

This information indicates usage of the compressor to air delivery.

## **SSR MODEL SE CONTROLLER MEMBRANE PAD**

### **START BUTTON**

Starts the compressor

When in the display table, causes exit to Checking Machine for 2 seconds and then Ready to Start

### **UNLOADED STOP**

When the compressor is running loaded, pressing this button causes the unit to unload, run 7 seconds unloaded and then stop.

If the compressor is running unloaded and has operated unloaded longer than 7 seconds, pressing the button causes the unit to stop immediately.

If the compressor is stopped, pressing this button causes the controller to perform a light check and the message display to show the software revision level.

### **SET BUTTON**

When the compressor is stopped, pressing the Set button allows entry into the customer set point routine.

When in the set point routine, pressing this button causes the controller to go to the next setting if the value was not changed. If the

value was changed, the new value will be saved in the memory prior to going to the next setting.

The Warning function can be reset by pressing this button once. The compressor could be either running or stopped.

The Alarm function can be reset by pressing the Set button twice.

### **UP ARROW/DOWN ARROW**

Used to raise or lower set point values

Used to enable or disable certain operation conditions. Example: Turn Auto S/S on or off.

Used to scroll through multiple Warnings or Alarms.

When either arrow is held during any of the previous 3 functions, the automatic scroll function will operate at a rate of once every 1/2 second.

Pressing both arrows at the same time when the compressor is stopped, causes the controller to calibrate pressure sensor 3APT.

### **DISPLAY SELECT**

Used to scroll through the pressure, temperature and hour readings as indicated on the left side of the Intellisys panel.

Pressing the Display Select button will immediately cause the controller to exit the set point routines.

### **UNLOAD/LOAD**

Is used to manually put the compressor into an unload mode if the unit was in ACS, Modulation Only or On/Off Line control.

Used to manually place the unit into an ACS, Modulation Only or On/Off Line control mode.

**SSR MODEL SE CONTROLLER -  
HIDDEN BUTTON OPERATION  
(EPROM revision level 1.3 or higher)**

**HIDDEN LEFT** Located between the Power Indicator light and the Start button.

**TO ACCESS** Have "READY TO START" or "START LOCAL/REMOTE" showing in the message display. Press the Unload/Load button once and then press the Hidden Left button within three seconds.

**CONTENT** Last Alarm Recall plus operating conditions at the instant of the alarm are stored in the memory and can be reviewed using the Display Select button.

**TO EXIT** Press the Set button twice.

**HIDDEN RIGHT** Located between the Automatic Restart Indicator light and the Unloaded Stop button.

**TO ACCESS** Have "READY TO START" or "START LOCAL/REMOTE" showing in the message display. Press the Unload/Load button once and then press the Hidden Right button within three seconds.

**CONTENT**

- A) Language- English/French/Spanish/Portuguese
- B) Temperature and pressure selections
  - 1) Degrees F. and PSI
  - 2) Degrees C. and KPA
  - 3) Degrees C. and PSI
  - 4) Degrees C. and BAR
  - 5) Degrees C. and KG/CM+
- C) Rated pressures
  - 1) PSI = XF@100 / EP@125 / HP@140 / Special@150 / 165/ XHP@200
  - 2) BAR = 7 / 8.5 / 9.6 / 10.3 / 11.4/ 13.8
  - 3) KG/CM+ = 7 / 8.5 / 9.8 / 10.5 / 11.4/ 14.0
  - 4) KPA = 700 / 850 / 960 / 1030 / 1380 / 1140
- D) Starter options
  - 1) Star-Delta (Timer adjusts between 5 and 15 seconds)
  - 2) Full voltage
  - 3) No starter
- E) LCD (Liquid Crystal Display) contrast
  - 1) Use the Up/Down arrows to adjust the contrast and then press the Set button.
- F) Hour meter settings
- G) Modulation On/Off

**TO EXIT**

Press the Display Select button once or wait for 30 seconds.

#### GENERAL INFORMATION

1 BAR = 14.5 PSI

1 KPA (Kilo Pascal) = BAR X 100

1 KG/CM+ = 14.22 PSI

Degrees Celsius = ( Fahrenheit - 32 )  $\approx$  1.8

KO035 10 March '98

Degrees Fahrenheit = 1.8 X Celsius + 32

### **SSR MODEL SE AUTOMATIC START/STOP OPERATION EPROM REVISION LEVEL 1.1 AND HIGHER**

For Automatic Start/Stop operation (standard in EPROM Revision Level 1.5 and higher), Automatic Start/Stop kit 39694153 or Combination kit 39694179 containing Automatic Start/Stop, Remote Start/Stop and the Power Outage Restart Option must be installed and activated in the set-point routine.

When in operation, the compressor must then meet two specific timing intervals before the Intellisys controller will stop the unit in an Automatic Start/Stop situation.

For this discussion, the timers will be called timer "A" and timer "B".

First: Timer "A" prevents the compressor from automatically starting more than 6 times an hour by requiring the unit to run at least 10 minutes after each automatic start.

This 10 minute run period can be loaded, unloaded or a combination of the two and allows dissipation of heat generated within the motor windings during start-up.

Second: After the compressor has started and reached the Off-Line setting and unloaded, timer "B" requires the unit to run unloaded for a period of time the operator can adjust between 2 and 20 minutes.

The setting of timer "B" is part of the customer set-point routine and the timer cancels any accumulated time if the compressor reloads before the timer cycle has finished.

An important point...this unloaded run time may, or may not, be included in the mandatory 10 minute run time used to cool the motor windings.

When the compressor has completed the settings of both timer "A" and timer "B", the Intellisys controller stops the compressor, turns on the Automatic Restart light and places "Auto Restart" in the message display.

Pressure sensor 3APT continues to monitor the package discharge pressure and sends information to the controller which automatically restarts the compressor when the pressure falls to the On-Line setting.

An advantage to this method of Automatic Start/Stop control is allowing the compressor to stop much sooner in certain situations and timer settings, thereby reducing power costs.

Some Examples of Operation:

---

Example 1:

The operator selects an unloaded run time of 2 minutes in the set-point routine and starts the compressor. The unit runs loaded for 8 minutes, unloads and then runs unloaded for two more minutes.

The total running time is 10 minutes which satisfies timer "A" plus the unit ran two minutes unloaded which also satisfies timer "B".

Therefore, the unit stops automatically.

This example shows how timer "B" can sometimes be included within the timer "A" interval. Think of the two timers as running parallel.

---

Example 2:

The operator selects an unloaded run time of 3 minutes in the set-point routine and starts the compressor. The unit runs loaded for 10 minutes and then unloads.

At this point, timer "A" has been satisfied but timer "B" still wants the compressor to run unloaded 3 more minutes before allowing an automatic stop.

The total run time for this example will be 13 minutes.

Remember...if the unit reloads before timer "B" finishes the 3 minute setting, the partial time is canceled and timer "B" must restart the 3 minute cycle when the compressor unloads again.

---

Example 3:

The operator selects an unloaded run time of 10 minutes in the set-point routine and starts the compressor. The unit runs loaded 12 minutes and then unloads.

After 12 minutes of running, the 10 minute mandatory run-time for timer "A" has been met but the compressor must continue to run unloaded an additional 10 minutes to satisfy timer "B".

After 10 minutes of unloaded run time, the compressor is stopped automatically and the total run time was 22 minutes.

## **SSR MODEL SE ALARM SHUTDOWNS**

Should the Intellisys controller sense an alarm condition, an operating compressor will be immediately stopped.

All motor contactor coils and solenoid valves will be de-energized; the red Alarm LED will be lit; the message display will describe the alarm cause and the alarm relay will be energized to activate a remote alarm should the customer have one connected to the unit.

It is also important to understand that should an alarm condition develop while the compressor is not operating, the compressor can not be started, the solenoid valves remain de-energized, the red Alarm LED will be lit, the message display shows the alarm cause and the alarm relay is activated.

To clear either alarm condition, the cause must be corrected prior to resetting the Intellisys by pressing the Set button twice.

As the panel is resetting, the controller checks the condition of all sensor inputs, reviews all operating parameters and de-energizes the alarm relay to silence the customer's alarm. The resetting procedure takes about two seconds and "Checking Machine" shows in the message display as the controller gathers the information.

If all readings are within specifications, the controller places Ready to Start in the message display to indicate the compressor can be placed in service.

A description of the SE alarms is listed below for guidance. Remember...there may be more than one cause for an alarm. Investigation of any alarm will require a thorough understanding of the system and a logical approach to the problem.

**LOW SUMP PRESSURE** - An alarm that will cause a running compressor to be stopped should the wet-side sump pressure fall below 15 psi. Note: wet-side sump pressure is defined as the pressure between the discharge port of the air end and the separator element.

Whenever the Intellisys controller senses the Package Discharge Pressure to be less than 15 psi, a wet-side sump pressure check is made automatically and discreetly. There will be no change to the message display as the controller directs 10SV to connect 3APT to the wet-side of the sump for a two second pressure check.

If the compressor is running unloaded, the normal sump pressure should be approximately 25 psi and if this is the case, the compressor is allowed to continue to run and the controller returns to Package Discharge Pressure.

However, if the Package Discharge Pressure is still lower than 15 psi, the controller continues to check the sump pressure at 4 minute intervals for as long as Package Discharge Pressure remains below 15 psi.

Should the compressor be running loaded and the Package Discharge Pressure is less than 15 psi, the controller also makes the same automatic and discreet check.

In either case, unloaded or loaded, if the sump pressure is found to be lower than 15 psi, the compressor is immediately stopped and the alarm message LOW SUMP PRESS will appear in the display.

**HIGH AIR PRESSURE** - This alarm can occur from two separate pressure sources. The first, and most likely, is for the controller to sense Package Discharge Pressure to be 15 psi above the rated pressure of the controller. This pressure source is the normal connection for 3APT because the Intellisys always returns to Package Discharge Pressure at the end of the Display Select timer.

Examples of how the Package Discharge Pressure could rise too high would be if the SE unit is piped to a common air system with compressors having a higher pressure setting or loading the SE compressor with a closed isolation valve to cause the pressure to rise rapidly and exceed the rated pressure.

The second possible source for a High Air Pressure alarm is when the wet-side sump pressure is 20 psi plus the separator element differential higher than the rated pressure. An important point to understand here...the Intellisys controller discreetly records the separator element differential every loaded hour and stores the information in memory for use during this High Air Pressure alarm and to unload the compressor should 10SV be left in the sump position.

A faulty minimum pressure/check valve assembly or an extremely fouled separator element could create the high sump pressure.

In either case, the alarm can be caused by either high Package Discharge Pressure or high wet-side sump pressure.

The alarm message HIGH AIR PRESS is the same for either cause and the exact source must be investigated and corrected.

**HIGH AIREND TEMPERATURE** - A sensor known as 2ATT is located within the discharge port to monitor the air/oil temperature leaving the airend.

Should the temperature of the discharge port rise above 228°F. (109°C.) on an SE that is running, the Intellisys controller will shut the compressor down on an alarm condition and place HIGH AIREND TEMP in the message display.

In addition, should the temperature of the airend discharge port of a stopped compressor be greater than 217°F. (103°C.), the display will show HIGH AIREND TEMP and then alternate that message back and forth with MUST COOL DOWN. This condition is also a HIGH AIREND TEMP alarm and the controller will not allow the compressor to be started.

Either of the above two situations require 2ATT to cool below 217°F. (103°C.) before the Intellisys will clear the alarm when the Set button is pressed twice.

There can be many reasons for high airend temperatures and a partial list would include high ambient, dirty coolers, cooling air flow restrictions, low coolant level, faulty temperature control valve and others.

**STARTER FAULT 1SL & 2SL** - The Intellisys control system uses an auxiliary contact (1Sa, 1Ma and 2Ma) on each contactor to indicate when the contactor is either open or closed.

When the compressor is in operation and one of the contactors opens while the controller logic indicates it should be closed, the auxiliary contact also opens to signal the controller there is a problem. The controller issues a STARTER FAULT 1SL (1SA, 1MA) or STARTER FAULT 2SL (2MA) alarm. A loose wire, faulty starter coil or burned triac could cause the problem.

This alarm is also issued if the starter is directed to open and the contactor remains in the closed position.

**MAIN MOTOR OVERLOAD** - This alarm occurs whenever the contacts of the overload relay (1OL) open and remain open for at least 1 second. The relay contacts operate a 5 Volt DC circuit, are normally-closed and shipped from the factory in the automatic reset position.

Basically, 1OL has a heater element for each of the three phases supplying current to the main motor and each is sized for the amperage drawn at full load.

Should an overload condition develop to draw higher than normal current, the heater elements produce additional amounts of heat.

This additional heat is sensed by a small strip made of two dis-similar metals bonded together that have different rates of expansion. As the

bi-metal strip heats up, it bends as a result of the two different expansion rates until it trips the overload relay contacts to the open position.

As the contacts open, the compressor is shut down and MAIN MTR OVERLD will appear in the message display.

After the bi-metal strip has cooled enough to allow the alarm to be reset by pressing the Set button twice, the compressor can be restarted.

As stated earlier, the overload relay is factory set on automatic reset. However, 1OL can be adjusted to be manually reset by loosening a screw on the bottom of the relay and re-positioning a small plastic strip.

Some causes for a Main Motor Overload alarm could include low incoming voltage, operating above rated pressure, loose wire connections, faulty drive motor, improperly applied belt sheaves or incorrectly sized heater elements.

**FAN MOTOR OVERLOAD** - An alarm that occurs and will shut the compressor down whenever the fan motor overload relay 2OL opens and remains open for at least one second.

The operation of 2OL is the same as 1OL.

Some causes for a Fan Motor Overload alarm could include low incoming voltage, loose connections, wrong fan blade installed or improperly sized heater elements.

The message display will show FAN MTR

OVERLOAD as long as 2OL remains open.

After the relay has cooled and automatically or manually reset, the alarm can be cleared by pressing the Intellisys Set button twice.

**TEMPERATURE SENSOR FAILURE** - This alarm can be caused by an extremely high and unusual resistance value across 2ATT such as can be measured at approximately 0°F. (-17.8°C.) and below, a loose connection at junction J2, a broken wire in the temperature sensor 2ATT circuit or a faulty sensor.

The message display will show TEMP SENSOR FAIL and the Intellisys can only be reset after the problem has been located and corrected.

**REMOTE STOP FAILURE** - This alarm will be issued when the momentary remote stop switch is held open longer than 1 second to stop a unit but has not re-closed by the time the next restart attempt is made.

The restart attempt must be a result of an operator pressing the Intellisys Start button or the Remote Start button.

This alarm is only active if the Remote Start/Stop option prom is installed and the Remote Start/Stop feature turned ON in the Option Selection set-point routine.

**REMOTE START FAILURE** - An alarm that will occur when the Intellisys observes the Remote Start button has not been released after a unit is started remotely.

The alarm occurs if the Remote Start button is not released by the end of the star-delta transition time for star-delta units or 7 seconds after the Remote Start button is pressed on full-voltage systems.

This alarm is only active if the Remote Start/Stop option prom is installed and the Remote Start/Stop feature turned ON in the Option Selection set-point routine.

**CHECK MOTOR ROTATION** - After applying incoming power to an SE compressor, this alarm will occur if the controller has not measured 1 psi (or more) of positive sump pressure within 2 seconds after starting.

When positive pressure is not sensed, the controller instantly obtains a negative pressure signal from 3APT to determine if a vacuum is in the sump.

If vacuum is read, the controller assumes reverse rotation and issues the alarm to stop the compressor and place CK MTR ROTATION in the message display.

After the controller has once confirmed correct rotation, this alarm will not be checked again until the power supply has been removed from the unit.

**CALIBRATION FAILURE** - An alarm activated when attempting to calibrate 3APT with pressure still applied in excess of 10% of the sensor rating (approximately 22 psi).

The alarm serves to alert the operator of calibration error which could overload the unit or cause the relief valve to lift.

Prior to calibration, the compressor must be stopped and have Ready To Start or Start Local/Remote showing in the message display.

After all pressure has been vented from the compressor, both the Up and Down arrows must be pressed at the same time to initiate the calibration routine which then connects 3APT to the sump.

Using the sump connection for the calibration helps prevent calibration errors because the unit must be stopped during the procedure and the sump pressure should be 0 psi even though Package Discharge Pressure can remain at raised levels.

Should there be any concern of a small amount of pressure remaining in the sump, the black control tubing between the sump and the normally-closed port of 10 SV can be temporarily disconnected during calibration.

**NO CONTROL POWER** - This alarm will be issued when the Intellisys controller senses a loss of the 120 volt AC power supply to the triac circuit that controls the starter coils and solenoids.

A blown fuse (3FU), opening of the 120 volt contacts of the Emergency Stop switch, opening of the High Air Temperature switch (1ATS) or a loose/broken wire will cause this alarm.

**PRESSURE SENSOR FAILURE** - When the Intellisys controller receives a value from pressure sensor 3APT indicating the sensor has failed and

remained failed for at least 1 second initiates this alarm.

Typically, a broken or loose wire is the reason. Check for a good connection at the points where the cable connects to the sensor and at J3.

**EMERGENCY STOP** - This alarm results when the Emergency Stop button has been pressed to open both the 120V AC contact and the 5V DC contact.

To reset, the Emergency Stop button must be rotated slightly in a clockwise direction to release the contacts. Then, pressing the Set button twice will clear the alarm from the controller.

## **SSR MODEL SE ROTATION CHECK AND LOW PRESSURE ALARM**

When incoming power is applied to an SE compressor, the Intellisys controller will check for correct direction of drive motor rotation at the first start. This check is made one time after incoming power is applied and is not made during normal starting thereafter.

Basically, the Intellisys directs the Line/Sump solenoid 10SV to connect pressure sensor 3APT to the sump at the instant the Start button is pressed.

The pressure sensor looks for, and responds to, NEGATIVE pressure in the sump at a check-point two seconds after the Start button was pressed.

Negative pressure in the sump indicates reverse motor rotation and the Intellisys will stop the compressor, turn on the red Alarm light and place the words CK MTR ROTATION in the message window.

When the drive motor is rotating correctly, a POSITIVE pressure is generated in the sump and sensed by 3APT at the two second check-point. The compressor is allowed to run and the Intellisys directs 10SV to connect 3APT to the line.

The compressor continues to run and will load seven seconds after the Start button was pressed if the line pressure is lower than the On-Line setting.

Should the line pressure not rise above 15 psi within eight seconds after loading, the Intellisys

directs 10SV to reconnect 3APT back to the sump for a pressure check.

If the sump pressure is below 15 psi, the Intellisys stops the compressor, turns on the red Alarm light and puts LOW SUMP PRESS in the message window.

If the sump pressure rises above 15 psi, the Intellisys returns 3 APT back to line and starts a timer that switches 3APT back to the sump every four minutes to make a quick pressure check as long as the line pressure remains lower than 15 psi.

When the line pressure rises above 15 psi, the four minute timer is deactivated and 3APT remains connected to the line for loading and unloading pressures.

During normal operation, should the line pressure drop below 15 psi, the Intellisys switches 3 APT back to the sump for a pressure check. If the sump pressure is below 15 psi, the compressor shuts down, the red Alarm light comes on and LOW SUMP PRESS appears in the message window.

Had the sump pressure been higher than 15 psi during the pressure check, the Intellisys switches back to the line connection and starts the repeating timer but allows the compressor to continue to run. The timer causes the sump pressure to be checked every four minutes while the line pressure remains below 15 psi.

The above described checks are discrete in that the Intellisys makes each check without changing the message window information during the two second period.

## **SSR MODEL SE HIGH AIREND DISCHARGE TEMPERATURE WARNING AND ALARM**

The normal airend discharge temperature for an SE unit will be approximately 200°F. (93°C.) when the compressor is fully loaded.

This temperature level is maintained to prevent formation of water droplets within the sump that can reduce bearing life and separator element performance.

However, should the efficiency of the coolant/lubricant cooler be reduced by high ambient conditions or build-up of dirt on the exterior surface, the discharge temperature of the airend will increase.

A thermistor known schematically as 2ATT is installed directly into the discharge port to sense the air/oil temperature leaving the airend. This temperature information is forwarded to the Intellisys controller.

Basically, temperature sensor 2ATT assists the controller as they work together providing data about the temperature of the airend discharge, a warning feature that advises the airend discharge temperature is rising toward the shutdown point and finally, actual shutdown of the compressor should the temperature exceed the fixed trip point setting.

During normal use, the operator can select Airend Discharge Temperature on the Intellisys panel

message display by pressing the Display Select button . The temperature display can be pre-selected within the Hidden Right set-point routine to read as either Fahrenheit or Celsius. Depending on the selection made, either DEG F or DEG C will appear beside the temperature number in the message display to prevent confusion.

Basically, the Warning and Alarm system works as the following describes.

In the event the airend discharge temperature exceeds 221°F (105°C), the Warning feature becomes activated. The red Alarm LED on the upper right side of the Intellisys controller begins to flash at 1 second intervals and the message display alternates between whatever message was in the display at the moment the Warning began and High Airend Temperature. The compressor continues to operate and deliver air as required by system demand.

The green Display Select LED will be lighted and next to the message that was in the display when the Warning began. The two messages alternate back and forth.

If the Display Select button is pressed at this time to select Airend Discharge Temperature, the discharge port temperature as indicated by 2ATT will appear in the display.

Remember, the High Airend Temperature warning alternates with the message that existed in the display when the warning began or has since been selected by an operator using the Display Select button.

The warning continues to show in the display even if the airend cools down. This feature advises the operator that the compressor had overheated earlier and the cause should be investigated.

When the airend discharge temperature has cooled down only a degree or two, pressing the Set button once will clear the warning.

However, if the airend discharge temperature continues to rise and exceeds 228°F (109°C), the Intellisys immediately stops the compressor under an alarm condition.

The red alarm LED remains constantly lighted and High Airend Temperature shows continuously in the display.

To clear an alarm, the Set button must be pressed twice after the airend has cooled below 217°F (103°C).

If an attempt is made to clear the alarm while the airend discharge temperature remains above 217°F (103°C), the Intellisys adds and causes the message Must Cool Down to alternate with High Airend Temperature.

After cooling and correction of the overheating cause, the Intellisys can be cleared and the compressor placed back in service.



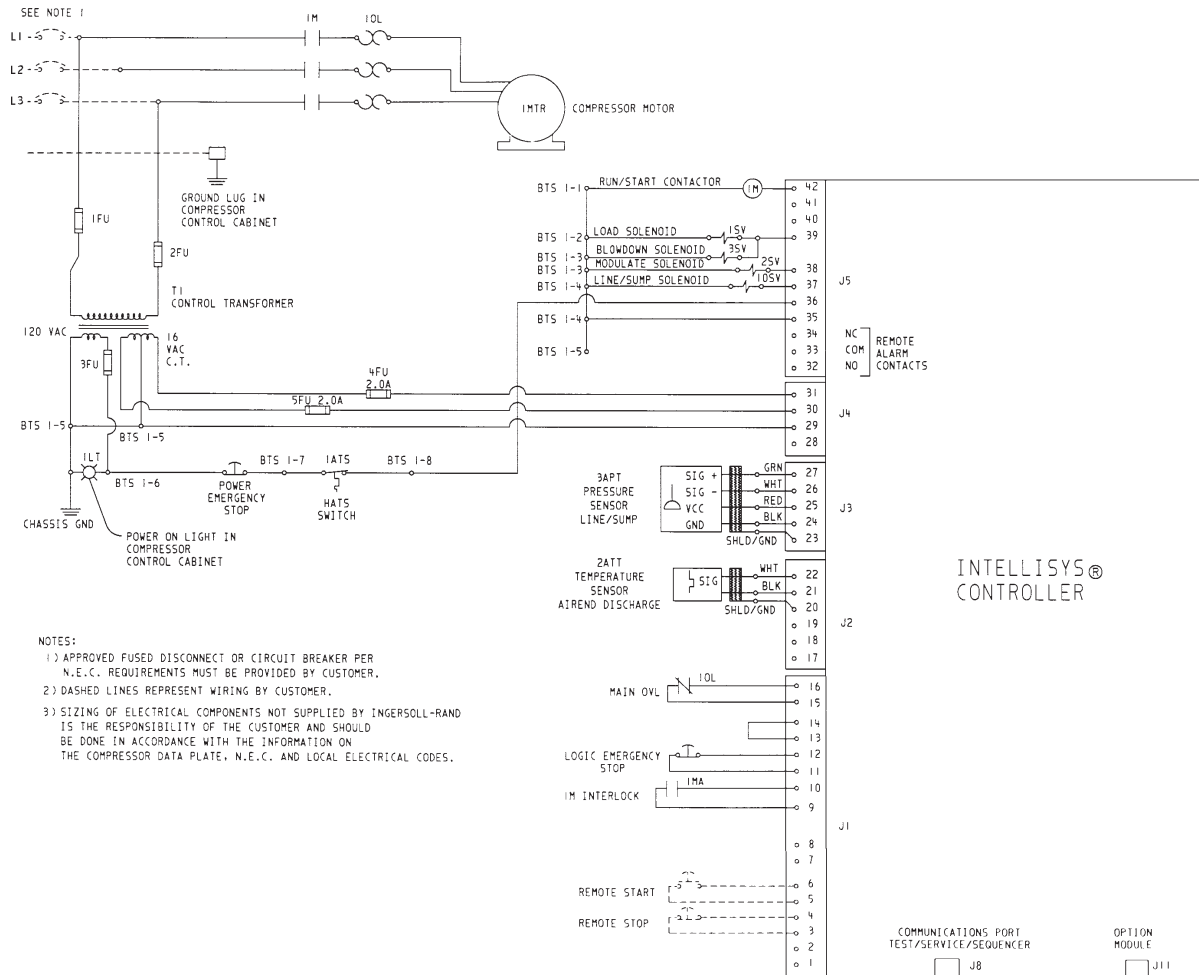

NOTES:

- 1) APPROVED FUSED DISCONNECT OR CIRCUIT BREAKER PER N.E.C. REQUIREMENTS MUST BE PROVIDED BY CUSTOMER.
- 2) DASHED LINES REPRESENT WIRING BY CUSTOMER.
- 3) SIZING OF ELECTRICAL COMPONENTS NOT SUPPLIED BY INGERSOLL-RAND IS THE RESPONSIBILITY OF THE CUSTOMER AND SHOULD BE DONE IN ACCORDANCE WITH THE INFORMATION ON THE COMPRESSOR DATA PLATE, N.E.C. AND LOCAL ELECTRICAL CODES.

## FULL VOLTAGE

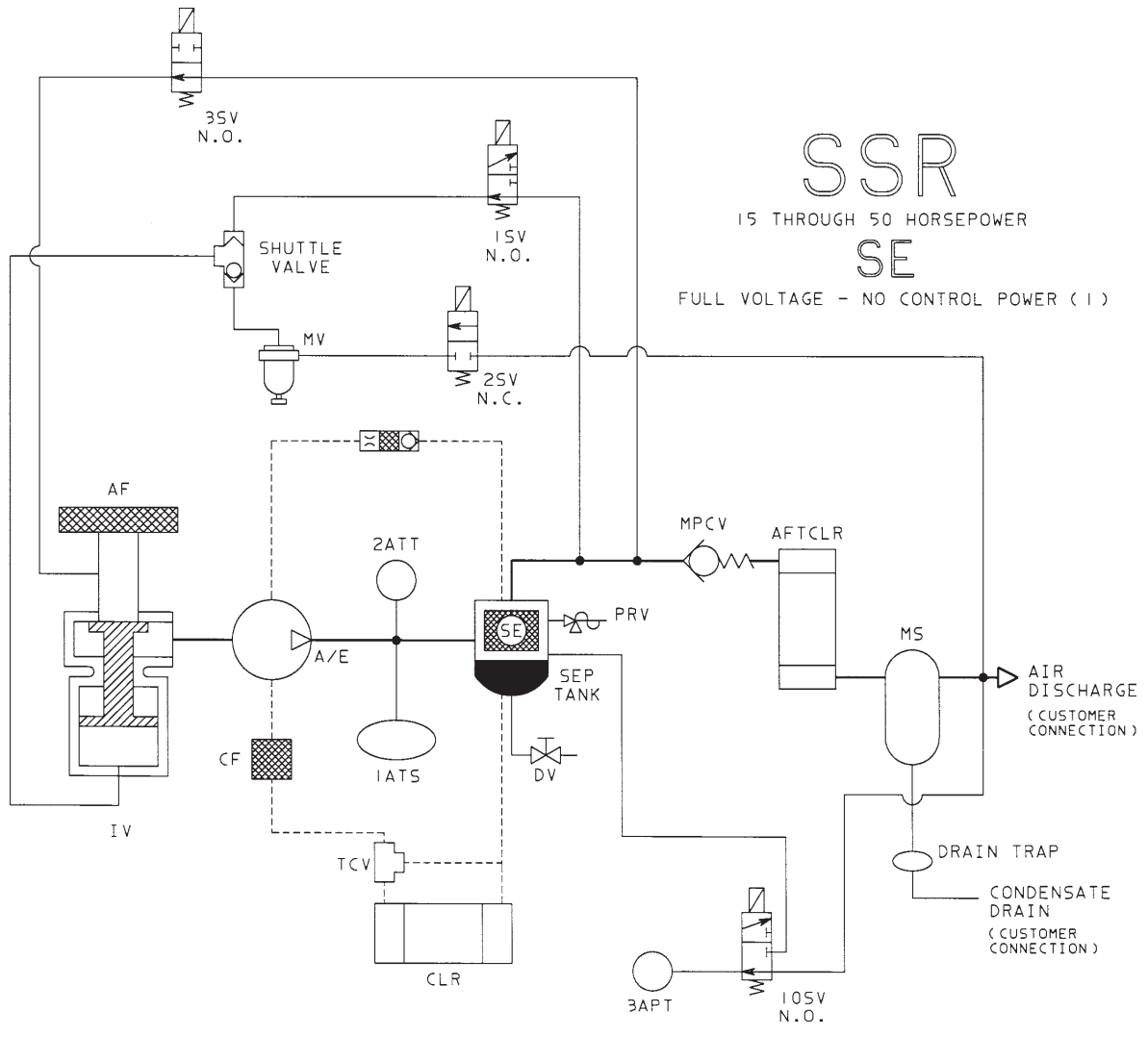

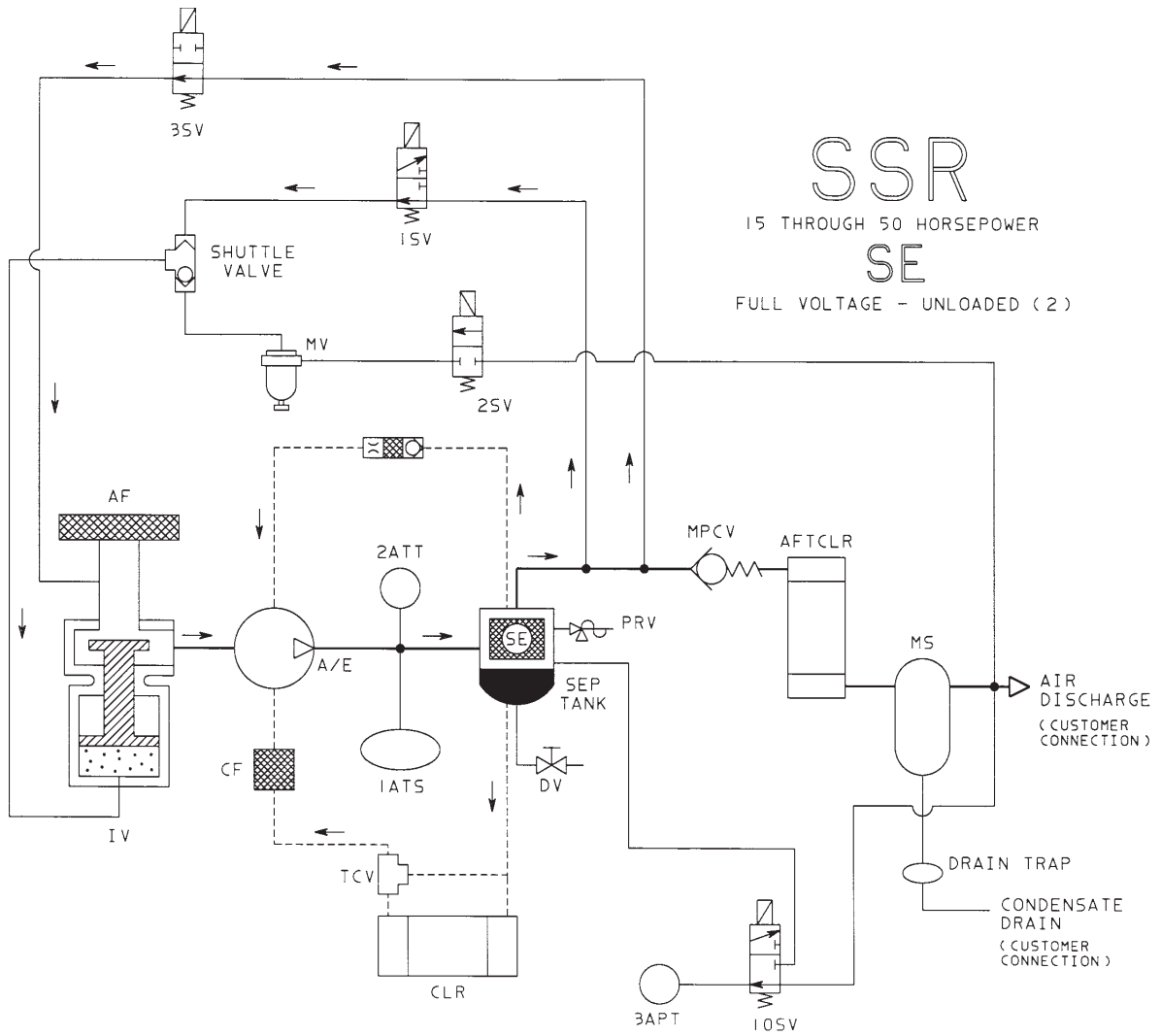

SSR

15 THROUGH 50 HORSEPOWER

SE

FULL VOLTAGE - UNLOADED (2)

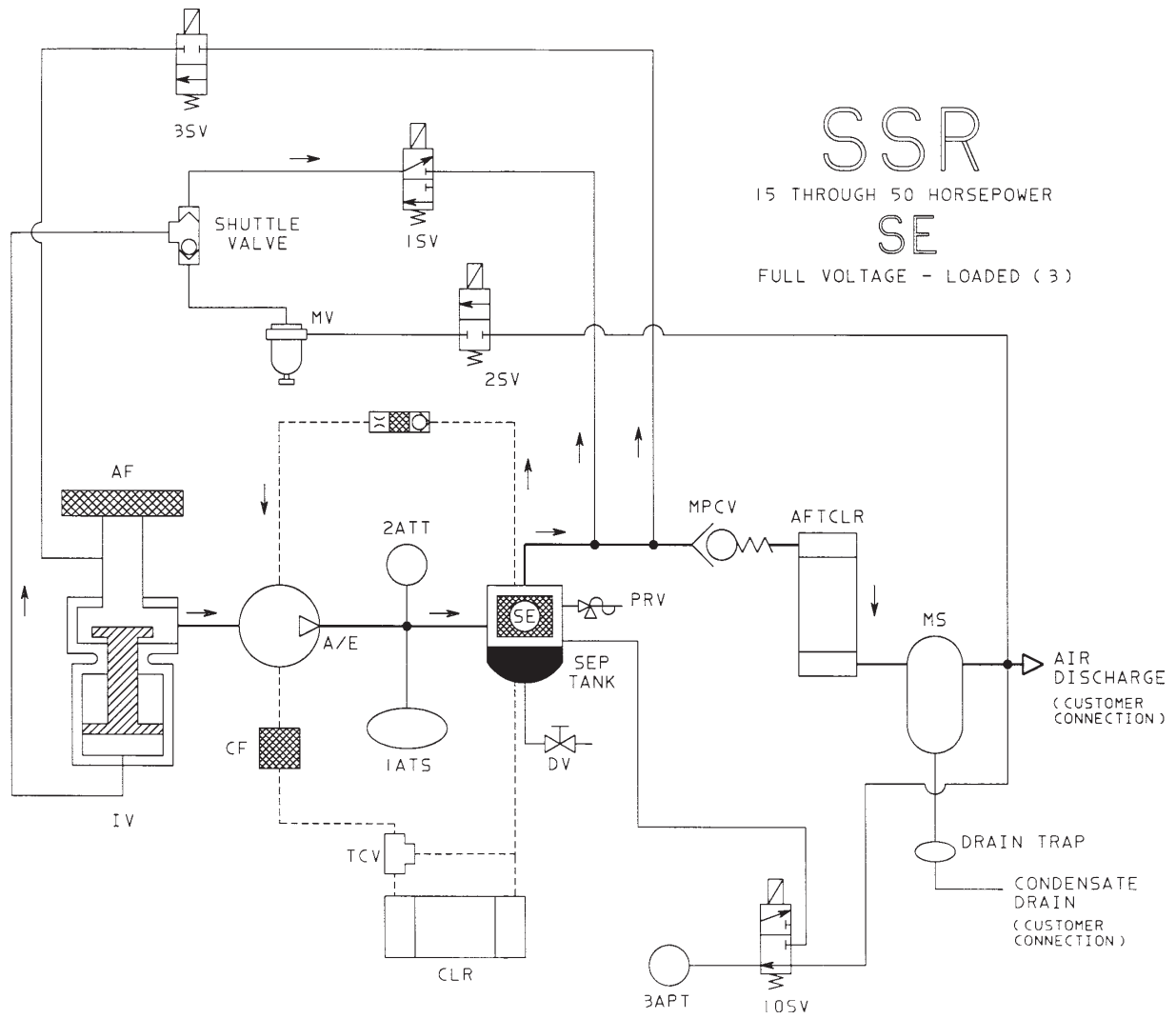

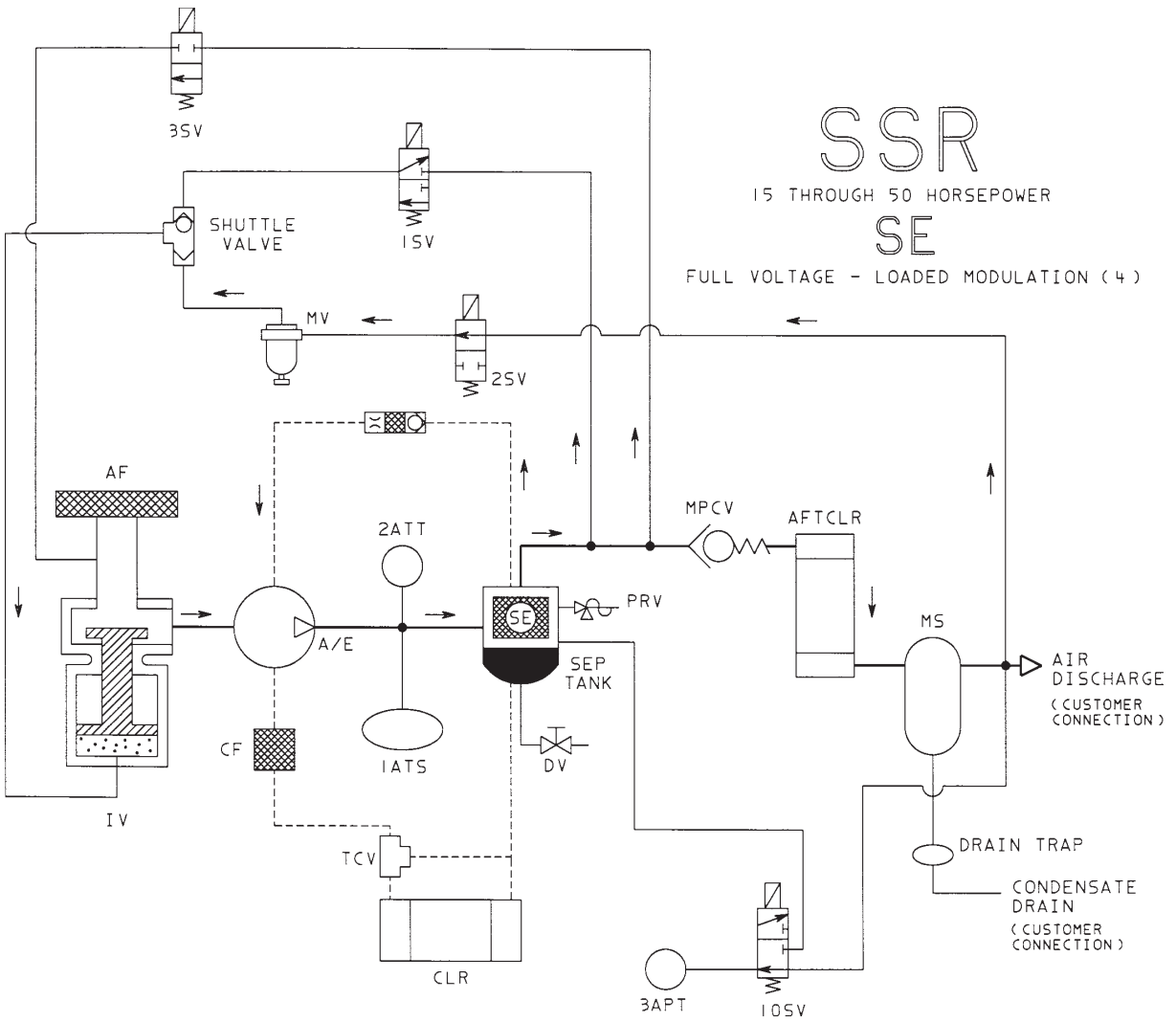

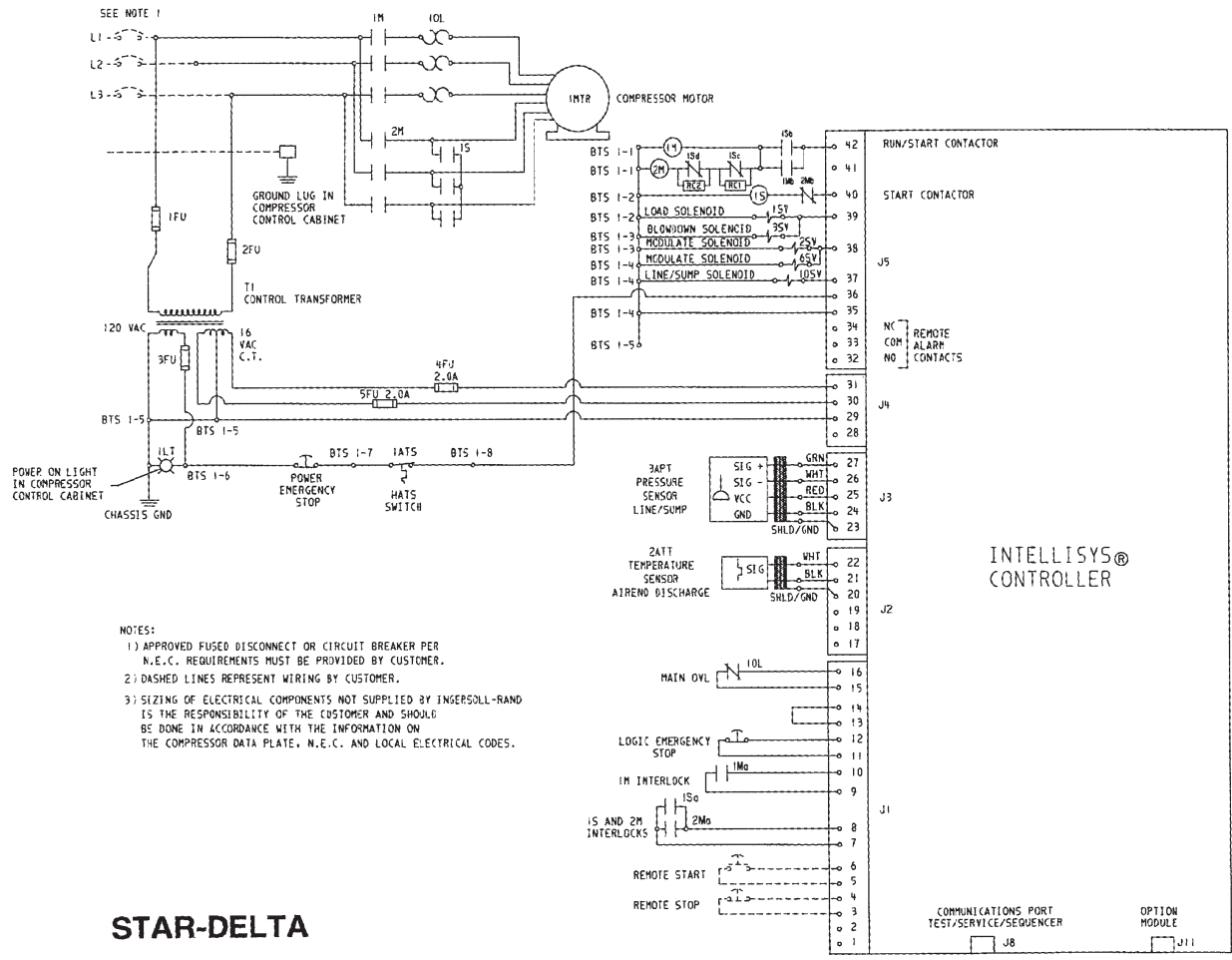

## STAR-DELTA

