



Ingersoll Rand X-IRI Communications Gateway Operators Manual

Before installing or starting this unit for the first time, this manual should be studied carefully to obtain a working knowledge of the unit and/or the duties to be performed while operating and maintaining the unit. RETAIN THIS MANUAL WITH UNIT. This Technical manual contains IMPORTANT SAFETY DATA and should be kept with the unit at all times.

More Than Air. Answers.

Online answers: <http://www.air.irco.com>

C.C.N. : 80445596
REV. A
DATE: June 2009

SECTION 1 — TABLE OF CONTENTS

<p>SECTION 1 — TABLE OF CONTENTS..... 1</p> <p>SECTION 2 — INTRODUCTION 2</p> <p>SECTION 3 — SAFETY..... 2</p> <p style="padding-left: 20px;">SAFETY PRECAUTIONS2</p> <p style="padding-left: 20px;">INSTALLATION2</p> <p style="padding-left: 20px;">OPERATION2</p> <p style="padding-left: 20px;">MAINTENANCE AND REPAIR.....3</p> <p>SECTION 4 — COMPRESSOR CONNECTION AND CONTROL 4</p> <p style="padding-left: 20px;">COMPRESSOR CONNECTION AND CONTROL.....4</p> <p style="padding-left: 20px;">INTELLISYS SOFTWARE REQUIREMENTS.....4</p> <p style="padding-left: 20px;">MODBUS RTU5</p> <p>SECTION 5 — INSTALLATION 8</p> <p style="padding-left: 20px;">UNIT LOCATION8</p> <p style="padding-left: 20px;">POWER SUPPLY8</p> <p style="padding-left: 20px;">DCS OR PLC CONNECTION9</p> <p style="padding-left: 20px;">COMPRESSOR IR-BUS CONNECTION9</p> <p style="padding-left: 20px;">DCS OR PLC COMMUNICATIONS10</p> <p style="padding-left: 20px;">COMPRESSOR COMMUNICATIONS:10</p> <p style="padding-left: 20px;">OPERATIONAL INDICATIONS10</p> <p style="padding-left: 20px;">RS-485 NETWORK12</p> <p style="padding-left: 20px;">MODBUS ADDRESS SELECTION.....13</p> <p style="padding-left: 20px;">MODBUS PORT SETUP SELECTION.....14</p> <p style="padding-left: 20px;">GATEWAY SOFTWARE VERSION DISPLAY15</p> <p style="padding-left: 20px;">COMMISSIONING PROCEDURE16</p> <p>SECTION 6 - PARTS LIST 17</p> <p>SECTION 7 - TECHNICAL DATA 17</p>	<p>SECTION 8 – INTELLISYS MODBUS TABLES18</p> <p style="padding-left: 20px;">TABLE 1 SSR (REDEYE) CONTROLLER 18</p> <p style="padding-left: 20px;">TABLE 2 SSR (SG) CONTROLLER 21</p> <p style="padding-left: 20px;">TABLE 3 SSR (SE) 15-100HP CONTROLLER 26</p> <p style="padding-left: 20px;">TABLE 4 SIERRA (REDEYE) 125-200 HP CONTROLLER ... 29</p> <p style="padding-left: 20px;">TABLE 5 SIERRA (SE) 50-100 HP CONTROLLER..... 32</p> <p style="padding-left: 20px;">TABLE 6 SIERRA (SG) 125-400 HP CONTROLLER 35</p> <p style="padding-left: 20px;">TABLE 7 SSR (SG) CONTACT COOLED RETROFIT CONTROLLER..... 39</p> <p style="padding-left: 20px;">TABLE 8 RECIP (REDEYE) CONTROLLER..... 44</p> <p style="padding-left: 20px;">TABLE 9 RECIP (SG) CONTROLLER..... 48</p> <p style="padding-left: 20px;">TABLE 10 RECIP BOOSTER (REDEYE) CONTROLLER..... 52</p> <p style="padding-left: 20px;">TABLE 11 NIRVANA (SGN) CC (CONTACT COOLED) CONTROLLER..... 56</p> <p style="padding-left: 20px;">TABLE 12 NIRVANA (SGNE) CC (CONTACT COOLED) CONTROLLER..... 60</p> <p style="padding-left: 20px;">TABLE 13 NIRVANA SGNE OF (OIL-FREE) CONTROLLER 65</p> <p style="padding-left: 20px;">TABLE 14 SSR UP (SE) CONTROLLER..... 69</p> <p style="padding-left: 20px;">TABLE 15 ESA (SE) 22 – 150 KW CONTROLLER 72</p> <p style="padding-left: 20px;">TABLE 16 R-SERIES (S3) CONTROLLER..... 75</p> <p style="padding-left: 20px;">TABLE 17 NIRVANA 15-30 KW (20-40 HP) DF CONTROLLER..... 77</p>
--	---



Refer to Section Indicated



Note



Important or Caution, Safety

SECTION 2 — INTRODUCTION

The **X-IRI Communication Gateway** is designed to interface the Intellisys Controllers on Ingersoll Rand Compressors with a Distributed Control System (DCS), Programmable Logic Controller (PLC), or any other device that is capable of communicating using the MODBUS RTU communications protocol.

The X-IRI provides MODBUS connectivity to Ingersoll Rand controllers that do not have built-in MODBUS capability. The X-IRI also provides address filtering and communication buffering capabilities to protect the integrity of the serial data network.

The X-IRI is designed to be DIN Rail mounted within the compressor control gear enclosure but can alternatively be mounted remotely within a separate enclosure.

SECTION 3 — SAFETY

SAFETY PRECAUTIONS



WARNING : Risk of Danger



WARNING : Risk of Electric Shock



WARNING : Risk of High Pressure



WARNING : Consult Manual

- Before installing or operating the X-IRI GATEWAY, take time to carefully read all the instructions contained in this manual, all compressor manuals, and all manuals of any other peripheral devices that may be installed or connected to the unit.
 - Electricity and compressed air have the potential to cause severe personal injury or property damage.
 - The operator should use common sense and good working practices while operating and maintaining this system. All applicable codes should be strictly adhered to.
 - Maintenance must be performed by adequately qualified personnel that are equipped with the proper tools.
- If raised platforms are required to provide access to the X-IRI GATEWAY, they must not interfere with normal operation or obstruct access. Platforms and stairs should be of grid or plate construction with safety rails on all open sides.

OPERATION

- The X-IRI GATEWAY must only be operated by competent personnel under qualified supervision.
- Never remove or tamper with safety devices, guards or insulation materials fitted to the X-IRI GATEWAY.
- The X-IRI GATEWAY must only be operated at the supply voltage and frequency for which it is designed.
- When main power is switched on, lethal voltages are present in the electrical circuits and extreme caution must be exercised whenever it is necessary to carry out any work on the unit.
- Do not open access panels or touch electrical components while voltage is applied unless it is necessary for measurements, tests or adjustments. Such work should be carried out only by a qualified electrician equipped with the correct tools and wearing appropriate protection against electrical hazards.
- All air compressors and/or other equipment connected to the unit should have a warning sign attached stating "THIS UNIT MAY START WITHOUT WARNING" next to the display panel.
- If an air compressor and/or other equipment connected to the unit is to be started remotely, attach two warning signs to the equipment stating "THIS UNIT CAN BE STARTED REMOTELY". Attach one sign in a prominent location on the outside of the equipment, and the other sign inside the equipment control compartment.

INSTALLATION

- Installation work must only be carried out by a competent person under qualified supervision.
- A fused isolation switch must be fitted between the main power supply and the X-IRI GATEWAY.
- The X-IRI GATEWAY should be mounted in such a location as to allow operational and maintenance access without obstruction or hazard and to allow clear visibility of indicators at all times.

MAINTENANCE AND REPAIR

- Maintenance, repairs or modifications must only be carried out by competent personnel under qualified supervision.
- If replacement parts are required, use only genuine parts from the original equipment manufacturer, or an alternative approved source.
- Carry out the following operations before opening or removing any access panels or carrying out any work on the X-IRI GATEWAY:
 - i. Isolate the X-IRI GATEWAY from the main electrical power supply. Lock the isolator in the “OFF” position and remove the fuses.
 - ii. Attach labels to the isolator switch and to the unit stating “WORK IN PROGRESS - DO NOT APPLY VOLTAGE”. Do not switch on electrical power or attempt to start the X-IRI GATEWAY if such a warning label is attached.
- Make sure that all instructions concerning operation and maintenance are strictly followed and that the complete unit, with all accessories and safety devices, is kept in good working order.
- The accuracy of sensor devices must be checked on a regular basis. They must be calibrated when acceptable tolerances are exceeded. Always ensure any pressure within the compressed air system is safely vented to atmosphere before attempting to remove or install a sensor device.
- The X-IRI GATEWAY must only be cleaned with a damp cloth, using mild detergents if necessary. Avoid the use of any substances containing corrosive acids or alkalis.
- Do not paint the control faceplate or obscure any indicators, controls, instructions or warnings.

SECTION 4 — COMPRESSOR CONNECTION AND CONTROL

COMPRESSOR CONNECTION AND CONTROL

The X-IRI Gateway module is designed to interface to any Ingersoll Rand Intellisys controlled compressor. All Ingersoll Rand compressors equipped with Intellisys controllers must use this interface when communicating with MODBUS masters.

The X-IRI gateway prevents the compressor controller from seeing any communications that aren't directed toward the controller's network address. Additionally, the X-IRI will buffer communications so that the compressor controller will not receive a command greater than once every 500 milliseconds.

⚠ Setting a MODBUS polling rate of less than 500 milliseconds will not cause a quicker response from X-IRI.

The PLC or DCS communicates to the X-IRI Gateway via a two wire, RS-485 network utilizing the MODBUS RTU protocol.

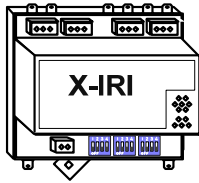

The X-IRI Gateway module is installed within the compressor control cabinet and connected to the PLC or DCS using Belden 9841 or equivalent RS-485 cable.

INTELLISYS SOFTWARE REQUIREMENTS

⚠ **Each Intellisys controller must have its controller software revision at or above a certain minimum level to work with the IRI.**

The machine types and required software EPROM minimum version levels are listed below. Check the machine to be connected to an IRI for the appropriate EPROM. If the EPROM is not of the correct minimum version level, the appropriate EPROM may be ordered from your local Ingersoll Rand Distributor or Air Center.

Machine Type EPROM Minimum Version Level

SSR 50-450 Horsepower - 1 stage (Red Eye)	2.3
SSR 50-450 Horsepower - 2 stage (Red Eye)	2.3
SSR SG	1.0
15-50 Horsepower	1.4
Sierra 50-100 Horsepower (SE)	1.2
Sierra 100-200 Horsepower (Red Eye)	2.5
Sierra 125-400 HP SG	1.0
Recip (Red Eye)	1.6
Recip SG	1.0
Nirvana SGN	1.0
Nirvana SGNe CC	2.0
Nirvana SGNe OF	1.0
Pegasus	1.0
ESA SE 22-150 KW	1.6

When monitoring compressor data only, no options are required to be installed in the Intellisys controller. If machine control is desired, the Remote Start/Stop and Sequence options must be installed and turned "On".

MODBUS RTU

MODBUS Table(s)

This document discusses generic MODBUS communications and how to implement the software specific 'MODBUS Table' information. MODBUS communication formatting may differ from controller to controller and you may require more than one 'MODBUS Table'.

Always check the software variant identification and version number for a controller with the variant and version of the 'MODBUS Table' supplied. In some instances the information contained in a 'MODBUS Table' may not be applicable to a controller installed with the same software variant but a different version number.

General

MODBUS RTU (Remote Terminal Unit) is a master-slave type protocol. An Intellisys Controller functions as the slave device. Information requests or commands are communicated from master to slave only through the X-IRI. The X-IRI will always respond to communications from a remote master device in accordance with the MODBUS RTU protocol standard.

The MODBUS protocol is used to communicate with personal computers (PC), Programmable Logic Controllers (PLC's), or Distributed Control Systems (DCS) over the Network port. The X-IRI only responds to two MODBUS commands, Read Holding Register 03 (03 Hex) and Preset Single Register 06 (06 Hex). (See Modicon MODBUS Protocol Reference Guide, PI-MBUS-300 Rev. J or later, for more details on MODBUS).

Communication Link

MODBUS is implemented using a two-wire RS485 industry standard communications link operating in master-slave mode.

⚠ Polarity of the two RS485 wires (L1+ and L2-) is important; reversal will disrupt communications.

RS485 Serial Data Format

The RS485 MODBUS port is a 2-wire operating with an asynchronous serial data format: 8 data bits / no parity / 1 or 2 stop bits (8,N,1 or 8,N,2) - transmitted at 9600 baud.

Message Data Format

The bytes of the MODBUS RTU message must be sent in one message package. The RTU protocol allows for a maximum pause of 1.5 byte-times between 2 consecutive bytes of a message.

⚠ A pause longer than 1.5 byte-times will render the message invalid and it will be ignored.

Message data format is dependent on function and will consist of a combination of the following elements:

- 1) Destination address (slave network address)
- 2) Function Code
- 3) Data start address (slave register start address)
- 4) Number of registers, number of bytes of data
- 5) Message data
- 6) CRC checksum

Message Destination Address

The 'destination address' must be correct for the 'slave' controller device for which the message is intended. An address can be from 1 to 127 decimal (01Hex to 7FHex). The SMG Box is transparent and addresses must be for the destination 'slave' controller or unit. Each controller or unit must be set with a unique address.

Slave Address	Function Code	Start Address	Number of Registers	CRC Check Sum
22	03	00 6F	00 02	F3 45

Slave Address = 22Hex = 34 Decimal

Message Function Codes

The message function code defines the required data processing operation of the slave controller. Although several types of message function codes are defined by the MODBUS standard, only the message function code types working directly with registers are implemented on controller units:

- 03H Read Holding Register(s) – Read
- 06H Preset Single Register - Write

Slave Address	Function Code	Start Address	Number of Registers	CRC Check Sum
22	03	00 6F	00 02	F3 45

Function Code = 03 = Read Holding Register

⚠ Any other message function code type will result in an EXCEPTION response.

Message Data Start Address

The message data start address (16bit word) designates the initial register address location in the controller from which the data is processed. Start address information is contained in the 'MODBUS Table'.

Slave Address	Function Code	Start Address	Number of Registers	CRC Check Sum
22	03	00 6F	00 02	F3 45

Start Address = 6F = 40112

⚠ High-byte transmitted first followed by low-byte.

Message Data

The message data content depends on the message function code type.

03H Read Holding Register(s)

The Number of Registers designates the 16bit integer value that determines the size (in 16bit 'word' registers) of the message data being requested. This is the number of 16bit registers to read. This information is contained in the 'MODBUS Table'.

⚠ A maximum of 32 registers can be read at one time.

Slave Address	Function Code	Start Address	Number of Registers	CRC Check Sum
22	03	00 6F	00 02	F3 45

The example above is a request to read offline pressure (register 40112) and online pressure (register 40113) from X-IRI address 22(Hex)

06H Preset Single Register

The Data byte 0 byte 1 designates the value of the 16bit integer word to be written to the Intellisys controller. This information is contained in the 'MODBUS Table'.

Slave Address	Function Code	Start Address	DATA byte 0 byte 1	CRC Check Sum
22	06	00 6F	00 5F	FE BC

The example above is a request to set offline pressure (register 40112) to 95 through X-IRI address 22(Hex).

Message CRC Checksum

The CRC (Cyclical Redundancy Check) is a check-sum generated by means of 'A001H polynomial'.

Slave Address	Function Code	Start Address	DATA byte 0 byte 1	CRC Check Sum
22	06	00 6F	00 5F	FE BC

The CRC is two bytes containing a 16-bit binary value (word). The CRC value is calculated by the transmitting device that appends the CRC to the end of the message. The receiving device recalculates the CRC value prior to processing of a received message and compares the result to the actual CRC value appended to the message. If the two values do not match the message is regarded as invalid.

The CRC is initiated by first preloading a 16bit register to all 1's (FFFF Hex). Then a process begins of applying each consecutive 8bit byte of the message to the register contents using an exclusive 'OR' calculation. The result is shifted one bit in the direction of the least significant bit (LSB), with the most significant bit (MSB) set at '0'. The LSB is then examined; if '1' the register content is applied to the polynomial value 'A001' Hex (1010 0000 0000 0001) using an exclusive 'OR' calculation - if '0' no exclusive OR takes place.

This process is repeated until eight 'bit' shifts have been performed. After the eighth bit shift, the next 8bit message byte is applied to the register contents using an exclusive 'OR' calculation. The bit shift and re-calculation process is then repeated again. When all message bytes have been processed the final content of the 16bit register is the message CRC value.

Only the 8bits of 'data' in each message character is used for generating the CRC; start, stop and parity bits are ignored.

⚠ When the 16bit CRC value is appended to a message, the low order byte must be transmitted first followed by the high order byte. An incorrect or byte reversed check sum will render the message invalid and it will be ignored.

Slave Response Timeout

A slave controller may not answer immediately. Ensure the 'slave timeout' setting of the 'master' device is set to a value no less than 500ms. If the 'slave' device fails to receive a valid message due to a communication disruption, parity error, CRC error or other reasons, no response is given and the master must process a timeout condition in this instance. If the 'slave' receives a valid message that cannot be processed an exception response will be returned.

Message Answer From Slave to Master

The format of the 'slave' controller answer is similar to the original master request format; the message data content depends on the message function code type.

The 'address' and 'code' of the slave answer is identical to the original request message; the address is the 'slave' device address and the 'code' is a repeat of received function code type from the master. The remainder of the message is dependent on the requested function code type. The CRC checksum is re-calculated for the answer message characters using the specified CRC process.

03H Read Holding Register(s)

Slave Address	Function Code	Number of Data Bytes to Follow	DATA 1st Register byte 0 byte 1	DATA 2nd Register byte 2 byte 3	CRC Check Sum
01	03	04	00 5F	00 55	F3 45

The example above is a request to read offline pressure 5FHex (95) (register 40112) and online pressure 55Hex (85) (register 40113) from X-IRI address 22(Hex)

06Hex - Preset Single Register

Slave Address	Function Code	Start Address	DATA byte 0 byte 1	CRC Check Sum
22	06	00 6F	00 5F	FE BC

The example above is a request to set offline pressure (register 40112) to 95 through X-IRI address 22(Hex).

Exception Response

If the 'slave' device receives a request that cannot be processed an 'exception response' is given. An exception response message consists of the following elements:

- o Slave Network Address (1 byte): Slave address identification
- o Function Code (1 byte): In a normal response, the slave repeats the function code of the original master request. All function codes have an MSB (most significant bit) of 0 (values are all below 80 hexadecimal). In an exception response, the slave sets the MSB of the function 'code' to 1. This makes the 'code' value 80 Hex greater than the received 'code' value from the master.
- o Data (1 byte): The 'data' response will contain a '1 byte' value exception code.
- o CRC Checksum (2 byte).

Slave Address	Function Code	Error Code	CRC Check Sum
01	90	04	4D C3

Exception Codes:

- 01H Illegal Function Code -- The requested 'code' function is not supported.
- 02H Illegal Data Address -- The requested 'data start address' is not supported.
- 03H Illegal Data Value -- The requested 'data' value is not supported.
- 04H Function Error -- The slave cannot execute the request or the request type is inhibited.

Troubleshooting

Problem:

- o No 'slave' response or corrupt MODBUS message

Solution:

- o Check that the 'slave' controller is set for the anticipated slave address
- o Check that all 'slave' controllers are set with a unique system address
- o Check that the controller is set for MODBUS RTU mode (if applicable)
- o Check that the 'master' is operating in MODBUS RTU mode
- o Check that the 'master' baud rate, parity bit and number of stop bits are correct
- o Check that the 'master' response timeout is set for a minimum of 500ms
- o Check that the 'master' is implementing the specified CRC check sum process
- o Check RS485 wiring polarity and security of connections

Problem:

- o Last character of MODBUS message is corrupted

Solution:

- o Add a delay of 2ms after last character received before releasing RTS signal

Problem:

- o The MODBUS master message is reflected in the slave answer

Solution:

- o Inhibit RX/TX echo on 'master' device communications port

SECTION 5 — INSTALLATION

INSTALLATION

! It is recommended that installation and commissioning be carried out by an authorized and trained product supplier.

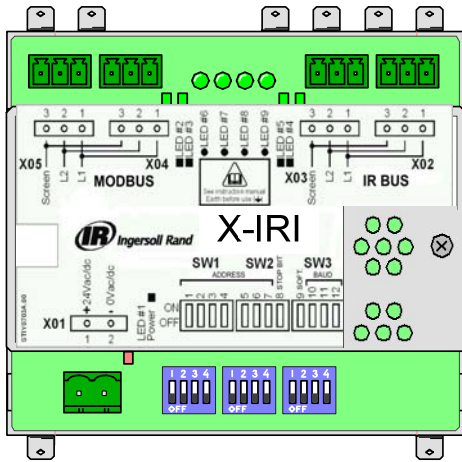

UNIT LOCATION

The X-IRI Gateway is DIN Rail mounted and can be located within the compressor control enclosure or remotely within a separate enclosure. X-IRI Gateway must be located within 33ft (10m) of the compressor controller.

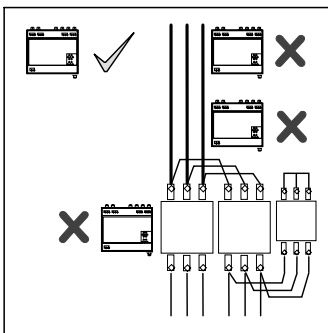

! Avoid mounting the X-IRI Gateway near high voltage cables, high voltage devices or equipment or motor starter contactors.

POWER SUPPLY

The X-IRI Gateway is powered by an external 24VDC power supply. The AC supply voltage for the 24VDC power supply is derived from the compressor's 110VAC or 230VAC internal AC supply.

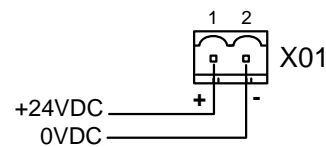
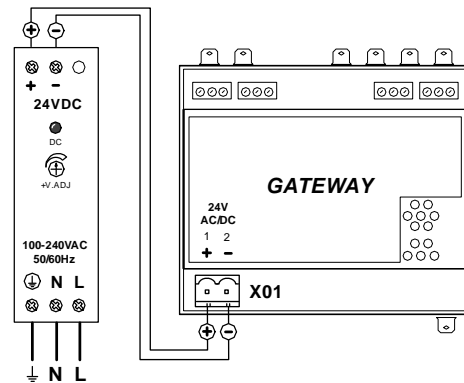
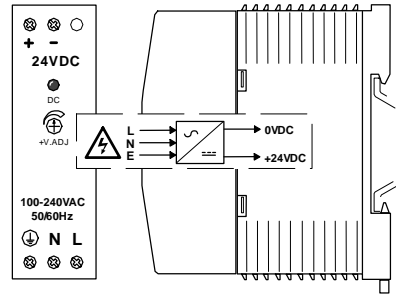

The power specification for the X-IRI Gateway is 24VDC (+/-10%) @ 35mA, 1W

It is possible to use the same 24VDC power supply to power multiple X-IRI Gateway devices.

! Wire polarity is important

DCS OR PLC CONNECTION

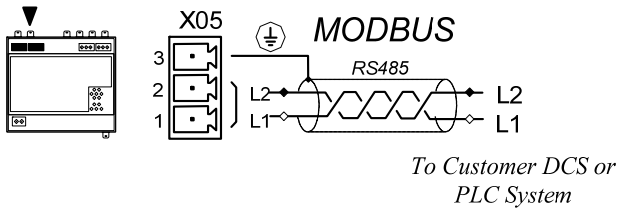

⚠ Wire polarity is important

Use 2-wire, 24 gauge (Belden 9841 or equivalent), twisted pair, earth shielded, data cable with a total system network length no greater than 4000ft (1219m).

COMPRESSOR IR-BUS CONNECTION

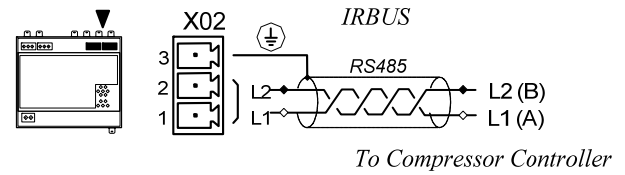

⚠ Wire polarity is important

Use 2-wire, 24 gauge (Belden 9841 or equivalent), twisted pair, earth shielded, data cable with a length no greater than 33ft (10m).

For IntelliSys “Red Eye”, SG and SE equipped with an RJ11 RS-485 data communications connection port, use the RJ11 Modbus cable supplied with the X-IRI Gateway.

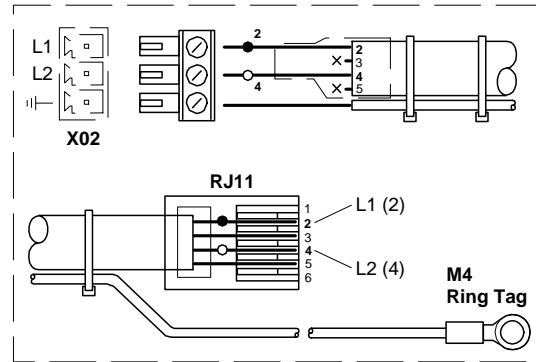

For IntelliSys SGN, SGNe and Nirvana 15-30kW (20-40HP) equipped with a Phoenix RS-485 data communications connector, use the RJ11 Modbus cable supplied with the X-IRI Gateway and modify as shown by removing the RJ11 Plug.

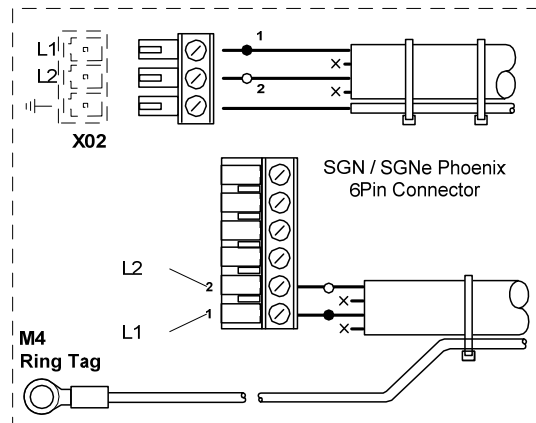

DCS OR PLC COMMUNICATIONS

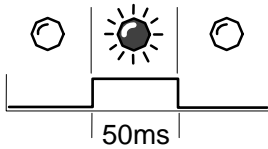
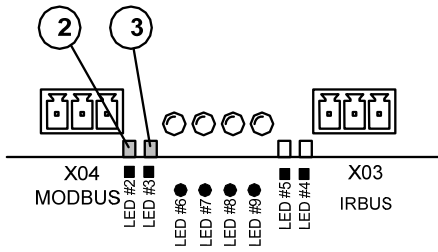

RX – Data Received:

② A valid MODBUS communication has just been received from the DCS or PLC unit. In normal operation this event should occur periodically depending on the polling rate.

TX – Data Transmitted:

③ A MODBUS broadcast or message has just been sent. To keep the link active, a MODBUS message must be sent at least once every 10 seconds.

COMPRESSOR COMMUNICATIONS:

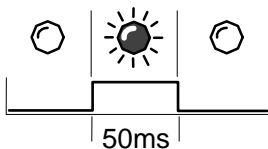
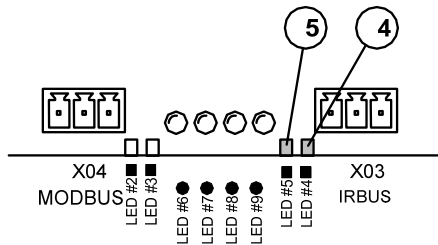

RX – Data Received:

④ A valid IRBUS communication has just been received from the compressor controller. In normal operation this event should occur at least once every 1/2 second.

TX – Data Transmitted:

⑤ An IRBUS message has just been sent to the compressor controller. In normal operation this event should occur at least once every 1/2 second.

OPERATIONAL INDICATIONS

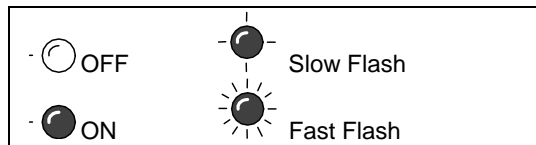
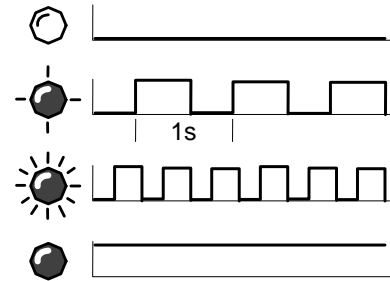
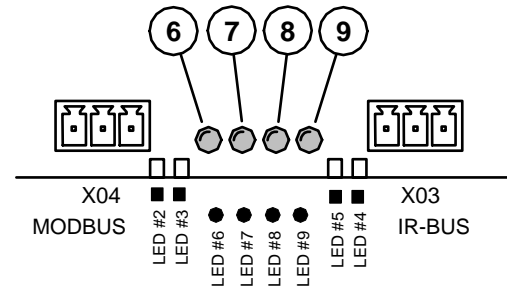

! At power on initialization, or when power has been removed, all operational indicators will fast flash for several seconds.

Normal Operation Example:

When there is valid communication with a MODBUS master and an IR-BUS compatible compressor controller the main operation indicators will light up as shown below.

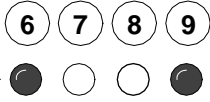

Normal operation function:

6 Modbus Communications with MODBUS master.

- OFF
- No valid communications with a MODBUS master
- ON: Valid communication with a MODBUS master, at least one read/write operation once every 10 seconds.

7 No function

- Always OFF: no other defined function

8 No function

- Always OFF: no other defined function

9 IR-BUS communication with a compressor controller

- OFF
- No valid communications with the compressor controller.
- ON: IR-BUS compressor controller detected and communication link established.

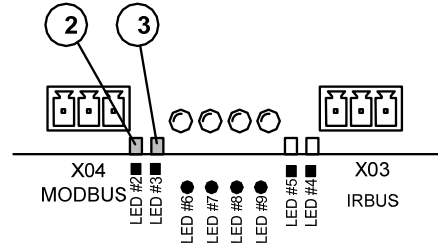

Led#2: Every flash indicates reception of a valid MODBUS message from the MODBUS master.

Led#3: Every flash indicates transmission of a valid MODBUS message to the MODBUS master.

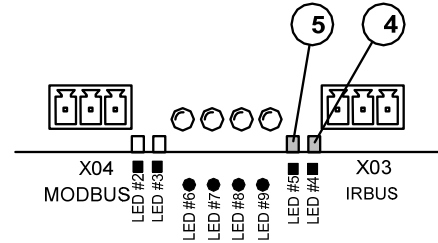

Led#5: Every flash indicates transmission of a valid IR-BUS message to the IR-BUS compressor controller.

Led#4: Every flash indicates reception of a valid IR-BUS message from the IR-BUS compressor controller.

RS-485 NETWORK

⚡))) RS-485 data communications and other low voltage signals can be subject to electrical interference. This potential can result in intermittent malfunction or anomaly that is difficult to diagnose. To avoid this possibility always use earth shielded cables, securely bonded to a known good earth at one end. In addition, give careful consideration to cable routing during installation.

1) Never route an RS-485 data communications or low voltage signal cable alongside a high voltage 3-phase power supply cable. If it is necessary to cross the path of a power supply cable(s), always cross at a right angle.

2) If it is necessary to follow the route of power supply cables for a short distance (for example: from a compressor unit to a wall along a suspended cable tray) attach the RS-485 or signal cable on the outside of an earthed cable tray such that the cable tray forms an earthed electrical interference shield.

3) Where possible, never route an RS-485 or signal cable near to equipment or devices that may be a source of electrical interference (for example: 3-phase power supply transformer, high voltage switchgear unit, frequency inverter drive module, radio communications antenna).

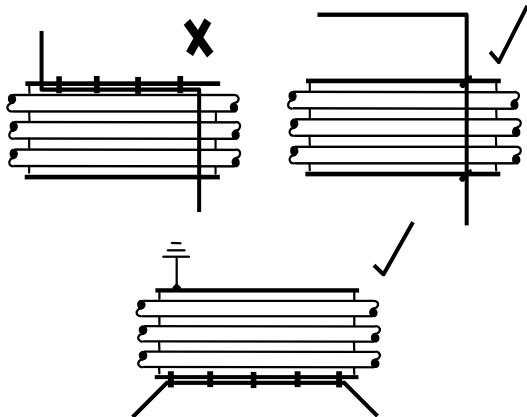

MODBUS ADDRESS SELECTION

Each compressor connected to the MODBUS network will have a unique assigned address, starting at compressor 1 increasing sequentially to the number of compressors connected to the MODBUS network. The MODBUS address is selected by using DIP switches 1, 2, 3, and 4 on SW1, and switches 1, 2, and 3 on SW2 on the X-IRI Gateway.

SW1, 1 to 4 and SW2, 1 to 3: Address Selection



The addresses are selected as shown in the following table: (Note: ON = 1, OFF = 0)

SW1				SW2			MODBUS Address (Decimal)	MODBUS Address (Hexl)
1	2	3	4	1	2	3		
0	0	0	0	0	0	0	1	1
1	0	0	0	0	0	0	1	1
0	1	0	0	0	0	0	2	2
1	1	0	0	0	0	0	3	3
0	0	1	0	0	0	0	4	4
1	0	1	0	0	0	0	5	5
0	1	1	0	0	0	0	6	6
1	1	1	0	0	0	0	7	7
0	0	0	1	0	0	0	8	8
1	0	0	1	0	0	0	9	9
0	1	0	1	0	0	0	10	A
1	1	0	1	0	0	0	11	B
0	0	1	1	0	0	0	12	C
1	0	1	1	0	0	0	13	D
0	1	1	1	0	0	0	14	E
1	1	1	1	0	0	0	15	F
0	0	0	0	1	0	0	16	10
1	0	0	0	1	0	0	17	11
0	1	0	0	1	0	0	18	12
1	1	0	0	1	0	0	19	13
0	0	1	0	1	0	0	20	14
1	0	1	0	1	0	0	21	15
0	1	1	0	1	0	0	22	16
1	1	1	0	1	0	0	23	17
0	0	0	1	1	0	0	24	18
1	0	0	1	1	0	0	25	19
0	1	0	1	1	0	0	26	1A
1	1	0	1	1	0	0	27	1B
0	0	1	1	1	0	0	28	1C

SW1				SW2			MODBUS Address (Decimal)	MODBUS Address (Hexl)
1	2	3	4	1	2	3		
1	0	1	1	1	0	0	29	1D
0	1	1	1	1	0	0	30	1E
1	1	1	1	1	0	0	31	1F
0	0	0	0	0	1	0	32	20
1	0	0	0	0	1	0	33	21
0	1	0	0	0	1	0	34	22
1	1	0	0	0	1	0	35	23
0	0	1	0	0	1	0	36	24
1	0	1	0	0	1	0	37	25
0	1	1	0	0	1	0	38	26
1	1	1	0	0	1	0	39	27
0	0	0	1	0	1	0	40	28
1	0	0	1	0	1	0	41	29
0	1	0	1	0	1	0	42	2A
1	1	0	1	0	1	0	43	2B
0	0	1	1	0	1	0	44	2C
1	0	1	1	0	1	0	45	2D
0	1	1	1	0	1	0	46	2E
1	1	1	1	0	1	0	47	2F
0	0	0	0	1	1	0	48	30
1	0	0	0	1	1	0	49	31
0	1	0	0	1	1	0	50	32
1	1	0	0	1	1	0	51	33
0	0	1	0	1	1	0	52	34
1	0	1	0	1	1	0	53	35
0	1	1	0	1	1	0	54	36
1	1	1	0	1	1	0	55	37
0	0	0	1	1	1	0	56	38
1	0	0	1	1	1	0	57	39
0	1	0	1	1	1	0	58	3A
1	1	0	1	1	1	0	59	3B
0	0	1	1	1	1	0	60	3C
1	0	1	1	1	1	0	61	3D
0	1	1	1	1	1	0	62	3E
1	1	1	1	1	1	0	63	3F
0	0	0	0	0	0	1	64	40
1	0	0	0	0	0	1	65	41
0	1	0	0	0	0	1	66	42
1	1	0	0	0	0	1	67	43
0	0	1	0	0	0	1	68	44
1	0	1	0	0	0	1	69	45
0	1	1	0	0	0	1	70	46
1	1	1	0	0	0	1	71	47
0	0	0	1	0	0	1	72	48

SW1				SW2			MODBUS Address (Decimal)	MODBUS Address (Hexl)
1	2	3	4	1	2	3		
1	0	0	1	0	0	1	73	49
0	1	0	1	0	0	1	74	4A
1	1	0	1	0	0	1	75	4B
0	0	1	1	0	0	1	76	4C
1	0	1	1	0	0	1	77	4D
0	1	1	1	0	0	1	78	4E
1	1	1	1	0	0	1	79	4F
0	0	0	0	1	0	1	80	50
1	0	0	0	1	0	1	81	51
0	1	0	0	1	0	1	82	52
1	1	0	0	1	0	1	83	53
0	0	1	0	1	0	1	84	54
1	0	1	0	1	0	1	85	55
0	1	1	0	1	0	1	86	56
1	1	1	0	1	0	1	87	57
0	0	0	1	1	0	1	88	58
1	0	0	1	1	0	1	89	59
0	1	0	1	1	0	1	90	5A
1	1	0	1	1	0	1	91	5B
0	0	1	1	1	0	1	92	5C
1	0	1	1	1	0	1	93	5D
0	1	1	1	1	0	1	94	5E
1	1	1	1	1	0	1	95	5F
0	0	0	0	0	1	1	96	60
1	0	0	0	0	1	1	97	61
0	1	0	0	0	1	1	98	62
1	1	0	0	0	1	1	99	63
0	0	1	0	0	1	1	100	64
1	0	1	0	0	1	1	101	65
0	1	1	0	0	1	1	102	66
1	1	1	0	0	1	1	103	67
0	0	0	1	0	1	1	104	68
1	0	0	1	0	1	1	105	69
0	1	0	1	0	1	1	106	6A
1	1	0	1	0	1	1	107	6B
0	0	1	1	0	1	1	108	6C
1	0	1	1	0	1	1	109	6D
0	1	1	1	0	1	1	110	6E
1	1	1	1	0	1	1	111	6F
0	0	0	0	1	1	1	112	70
1	0	0	0	1	1	1	113	71
0	1	0	0	1	1	1	114	72
1	1	0	0	1	1	1	115	73
0	0	1	0	1	1	1	116	74

SW1				SW2			MODBUS Address (Decimal)	MODBUS Address (Hexl)
1	2	3	4	1	2	3		
1	0	1	0	1	1	1	117	75
0	1	1	0	1	1	1	118	76
1	1	1	0	1	1	1	119	77
0	0	0	1	1	1	1	120	78
1	0	0	1	1	1	1	121	79
0	1	0	1	1	1	1	122	7A
1	1	0	1	1	1	1	123	7B
0	0	1	1	1	1	1	124	7C
1	0	1	1	1	1	1	125	7D
0	1	1	1	1	1	1	126	7E
1	1	1	1	1	1	1	127	7F

MODBUS PORT SETUP SELECTION



The MODBUS port setup is determined by means of DIP switch 4 on SW2 and DIP switches 2,3 and 4 on SW3. The selectable items are: baudrate and number of stop bits. Parity is not selectable and fixed at "no parity"

SW2-4: Stop Bit Selection



1 stop bit



2 stop bits

SW3-2...4: Baudrate Selection



1200 baud



2400 baud



4800 baud



9600 baud



19200 baud



38400 baud



57600 baud



115200 baud

GATEWAY SOFTWARE VERSION DISPLAY

SW3-1



When DIP Switch 1 on SW3 is set to the 'on' position the LED indicators (LED 2 to 9) will show the software version:

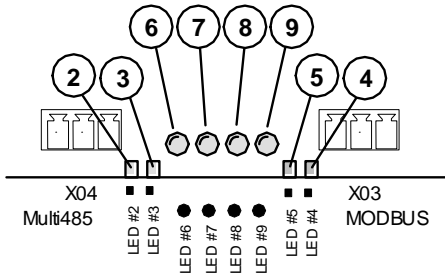

To establish the software version number (01 to 255) add together the 'value' associated with each illuminated LED.

● LED #	Value
6	= 1
7	= 2
8	= 4
9	= 8
2	= 16
3	= 32
5	= 64
4	= 128

⚠ Ignore LED 1 (power on indicator), located adjacent to X01; this LED will always be on when power is applied.

For example:

1) LED 6 and 8 = ON; all others off
 LED 6 = 1
 LED 8 = 4
 total = 5
 Software Version = 'E05'

2) LED 7 and 8 = ON; all others off
 LED 7 = 2
 LED 8 = 4
 total = 6
 Software Version = 'E06'

3) LED 6, 7, 9 and 2 = ON; all others off
 LED 6 = 1
 LED 7 = 2
 LED 9 = 8
 LED 2 = 16
 total = 27
 Software Version = 'E27'

The LED indicators will continue to display the the software version, regardless of operation, until switch 1 on SW3 is set to the 'off' position.

⚠ DIP Switch 1 on SW3 must always be set to the 'off' position for normal operation.

⚠ DIP Switch 1 on SW3 has no function with earlier software versions; if the LED indicators continue to operate normally when SW3-1 is switched on, the software is an earlier version; update the software.

Please refer to the table on the following page to assist in decoding the software version number.

Decoding The Software Version Number

LED#2	LED#3	LED#6	LED#7	LED#8	LED#9	LED#5	LED#4	Version
0	0	0	0	0	0	0	0	0
0	0	1	0	0	0	0	0	1
0	0	0	1	0	0	0	0	2
0	0	1	1	0	0	0	0	3
0	0	0	0	1	0	0	0	4
0	0	1	0	1	0	0	0	5
0	0	0	1	1	0	0	0	6
0	0	1	1	1	0	0	0	7
0	0	0	0	0	1	0	0	8
0	0	1	0	0	1	0	0	9
0	0	0	1	0	1	0	0	10
0	0	1	1	0	1	0	0	11
0	0	0	0	1	1	0	0	12
0	0	1	0	1	1	0	0	13
0	0	0	1	1	1	0	0	14
0	0	1	1	1	1	0	0	15
1	0	0	0	0	0	0	0	16
1	0	1	0	0	0	0	0	17
1	0	0	1	0	0	0	0	18
1	0	1	1	0	0	0	0	19
1	0	0	0	1	0	0	0	20
1	0	1	0	1	0	0	0	21
1	0	0	1	1	0	0	0	22
1	0	1	1	1	0	0	0	23
1	0	0	0	0	1	0	0	24
1	0	1	0	0	1	0	0	25
1	0	0	1	0	1	0	0	26
1	0	1	1	0	1	0	0	27
1	0	0	0	1	1	0	0	28
1	0	1	0	1	1	0	0	29
1	0	0	1	1	1	0	0	30
1	0	1	1	1	1	0	0	31
0	0	0	0	0	0	0	0	32
0	0	1	0	0	0	0	0	33
0	0	0	1	0	0	0	0	34
0	0	1	1	0	0	0	0	35
0	0	0	0	1	0	0	0	36
0	0	1	0	1	0	0	0	37
0	0	0	1	1	0	0	0	38
0	0	1	1	1	0	0	0	39
0	0	0	0	0	1	0	0	40
0	0	1	0	0	1	0	0	41
0	0	0	1	0	1	0	0	42
0	0	1	1	0	1	0	0	43
0	0	0	0	1	1	0	0	44
0	0	1	0	1	1	0	0	45
0	0	0	1	1	1	0	0	46
0	0	1	1	1	1	0	0	47
1	1	0	0	0	0	0	0	48
1	1	1	0	0	0	0	0	49

COMMISSIONING PROCEDURE

1) Before applying power to the X-IRI Gateway ensure:

- a) The MODBUS address is set to the correct value (switches 1-4 on SW1 and switches 1-3 on SW2)
- b) The MODBUS port setup matches the MODBUS master's requirements. Switches 4 on SW2 and switches 2-4 on SW3.
- c) The communication link wires from the Gateway to the compressor controller and the MODBUS master are connected, secure and the wire polarities are correct (L1, L2)

2) Apply power to the X-IRI Gateway

3) Ensure communications with the compressor controller is established – ensure indicator (9) is ON permanently.

4) Once the IR-BUS compressor controller communication link is established the MODBUS master unit can start operating. Any attempt from the MODBUS master to communicate before the IR-BUS link is established will simply result in the gateway not responding to the MODBUS master.

5) Once the MODBUS master communicates with the compressor controller through the gateway it should keep on doing so at least once every 10 seconds to keep indicator (6) from flashing.

6) In case the MODBUS master does not communicate at least once every 10 seconds the communication link is considered inactive: indicator (6) flashes and any earlier commands for the compressor controller to operate in “Host” mode are cancelled => the machine reverts back to local start/stop and load/unload control mode.

SECTION 6 - PARTS LIST

X-IRI Communication Gateway

Item	Part No.	Description
-	23461908	KIT, X-IRI Gateway
-	80445604	Manual, User CD
-	23462005	DIN Rail, Mounting
1	23461890	Module, X-IRI Gateway
2	39266101	Module, PSU-24VDC
3	39266135	Cable, RJ11 Modbus

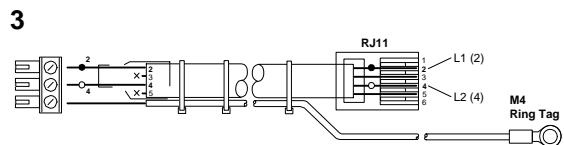
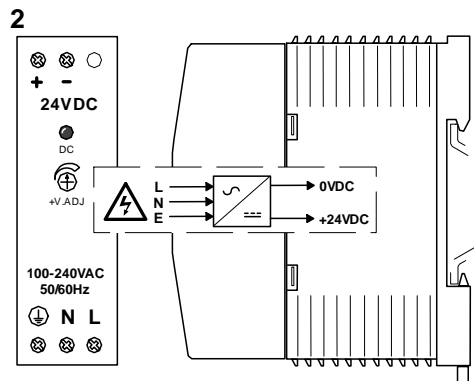
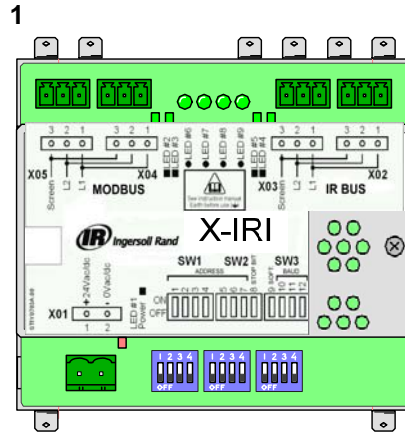

SECTION 7 - TECHNICAL DATA

Module, Gateway

Dimensions	3.8" x 3.4" x 2.2" 96mm x 85mm x 55mm
Weight	0.6lb (0.25kg)
Mounting	DIN, 35mm
Enclosure	IP20
Supply	24VDC/ac +/-15%
Power	1.0VA
Temperature	0°C to 46°C (32°F to 115°F)
Humidity	95% RH non-condensing

SECTION 8 – INTELLISYS MODBUS TABLES

TABLE 1 SSR (REDEYE) CONTROLLER

Register (40XXX)	Variable	Read/Write	Range	Notes
1	Status/Control	R/W		See FIGURE 1-1
3	Discharge Pressure	R		
4	Sump Pressure	R		
5	Inlet Vacuum	R		
6	Coolant Temperature	R		
7	Airend Temperature	R		
8	Discharge Temperature	R		
9	Low Ambient Coolant Temp.	R		Low Ambient Option
64	Total Hours (hours)	R		
65	Loaded Hours (hours)	R		
96	Language Selection	R		See FIGURE 1-2
97	Units of Measure	R		See FIGURE 1-2
98	Rated Pressure	R		
99	Rated Horse Power	R		See FIGURE 1-2
112	Offline Pressure	R/W	75 - (rated+3)	rated = rated pressure
113	Online Pressure	R/W	65-(offline-10)	offline = offline pressure
114	Display Timer (seconds)	R/W	10-600	
115	Star-Delta Time (seconds)	R		
116	Auto Start/Stop (AS/S) Time (minutes)	R/W	Feb-60	No Write if AS/S is off
117	Auto Start/Stop (AS/S) On/Off	R	0 or 1	0=Off, 1=On
118	Sequence Control On/Off	R	0 or 1	0=Off, 1=On
119	Remote Start/Stop On/Off	R	0 or 1	0=Off, 1=On
120	Mod Only On/Off	R/W	0 or 1	0=Off, 1=On
121	Power Out Restart Option (PORO)On/Off	R	0 or 1	0=Off, 1=On
122	PORO Time (seconds)	R/W	10-120	No Write if PORO is off
123	Load Delay Time (seconds)	R/W	0-60	
124	Min. Cooler Out Load Temp	R/W	30-150	Low Ambient Option
125	Unloaded Stop Time	R/W	10-30	
255	Warning Code	R		See FIGURE 1-4
256-270	Alarm Code History	R		See FIGURE 1-4
272-286	Inlet Vacuum Alarm History	R		
288-302	Sump Pressure Alarm History	R		
304-318	Discharge Pressure Alarm History	R		
320-334	Coolant Temperature Alarm History	R		
336-350	Airend Temperature Alarm History	R		
352-366	Discharge Temperature Alarm History	R		
368-382	Low Ambient Coolant Temp. History	R		Low Ambient Option
384-398	Run Hours Alarm History	R		
400-414	Load Hours Alarm History	R		
512-526	Status Alarm History	R		See FIGURE 1-3
999	IRI Version Number	R		Reads from IRI only

FIGURE 1-1 REGISTER 40001 STATUS / CONTROL

Bit 0: Host/Local (R/W) 0 = Local 1 = Host	Bit 6: Alarm (R) 0 = No Alarms 1 = Alarms
Bit 1: Run/Stop (R/W) 0 = Stop 1 = Run	Bit 7: Warning (R) 0 = No Warnings 1 = Warnings
Bit 2: Load/Unload (R/W) 0 = Unload 1 = Load	Bit 8: On/Off Line Mode (R) 0 = Not in On/Off Line Mode 1 = On/Off Line Mode
Bit 3: Modulating (R) 0 = Not Modulating 1 = Modulating	Bit 9: Mod/ACS or Mod Only (R) 0 = Not in Mod/ASC Mode 1 = Mod/ASC Mode
Bit 4: Unused	Bits 10-12: Unused
Bit 5: Stopped in Auto Restart (R) 0 = Not Stopped in Auto Restart	Bits 13-15: Unit Type (R) 001 = SSR controller

FIGURE 1-2 REGISTER CODES

Register 096: Language 0 = English 1 = Spanish 2 = French 3 = Portuguese	Register 097: Units of Measure 0 = °F and PSI 1 = °C and PSI 2 = °C and Bar 3 = °C and kPa 4 = °C and kg/cm2
Register 99: Rated Horse Power/Kilowatt	
0 = 50hp	7 = 250hp
1 = 60hp	8 = 300hp
2 = 75hp	9 = 350hp
3 = 100hp	10 = 400hp
4 = 125hp	11 = 450hp
5 = 150hp	12 = 500hp
6 = 200hp	

FIGURE 1-3 REGISTER STATUS ALARM HISTORY

Bit 0: Run/Stop (R) 0 = Stop 1 = Run	Bit 4: Stopped Auto Restart (R) 0 = Not Stopped in Auto Restart 1 = Stopped in Auto Restart
Bit 1: On/Off Line Mode (R) 0 = Not in On/Off Line Mode 1 = On/Off Line Mode	Bit 5: Unused
Bit 2: MOD/ACS Mode (R) 0 = Not in Mod/ACS Mode 1 = Mod/ACS Mode	Bit 6: Unused
Bit 3: Load/Unload (R)	Bit 7: Unused

FIGURE 1-4 REGISTER ALARM / WARNING CODES

SSR (Redeye) Controller	
Code	Description
01	Sensor Failure 1AVPT
02	Sensor Failure 3APT
03	Sensor Failure 4APT
04	Sensor Failure P4 (Spare)
05	Sensor Failure P5 (Spare)
06	Sensor Failure P6 (Spare)
07	Sensor Failure P7 (Spare)
08	Sensor Failure P8 (Spare)
09	Sensor Failure 2CTT
10	Sensor Failure 2ATT
11	Sensor Failure 4ATT
12	Sensor Failure 3CTT (Optional)
13	Sensor Failure T5 (Spare)
14	Sensor Failure T6 (Spare)
15	Sensor Failure T7 (Spare)
16	Sensor Failure T8 (Spare)
17	Starter Fault
18	Motor Overload (Main)
19	Fan Motor Overload
20	Door Open (Starter)
21	Stepper Limit Switch
22	Check Motor Rotation
23	Check Inlet Control System
25	Remote Stop Failure
26	Remote Start Failure
27	Check Inlet Control
28	Low Unload Sump Pressure
29	High Air Pressure
30	Low Sump Air Pressure
31	High A/E Discharge Temperature
32	Emergency Stop
33	Change Inlet Filter
34	Change Separator Element
35	Change Coolant Filter
36	1AVPT Sensor Error (Calibration)
37	Memory Fault

TABLE 2 SSR (SG) CONTROLLER

Register (40XXX)	Variable	Read/Write	Range	Notes
1	Status/Control	R/W		See FIGURE 2-1
3	Discharge Pressure	R		
4	Sump Pressure	R		
5	Inlet Vacuum	R		Divided by 10
6	Coolant Temperature	R		
7	Airend Temperature	R		
8	Discharge Temperature	R		
9	Low Ambient Coolant Temp.	R		Low Ambient Option
10	Separator Pressure Drop	R		
11	Spare Pressure Input 4	R		
12	Dry Side Sump Pressure	R		Spare Pressure Input #5 if no separator delta-p sensor option
13	Spare Pressure Input 6	R		
14	Spare Pressure Input 7	R		
15	Remote Pressure	R		Spare Pressure Input #8 if no remote sensor option
16	Spare Temperature Input 5	R		
17	Spare Temperature Input 6	R		
18	Spare Temperature Input 7	R		
19	Spare Temperature Input 8	R		
20	% Load Modulation	R		
64	Total Hours (hours)	R	0 – 9999	Less Than 10000
65	Loaded Hours (hours)	R	0 – 9999	Less Than 10000
66	Ten Thousand Total Hours	R		Multiply by 10000
67	Ten Thousand Loaded Hours	R		Multiply by 10000
96	Language Selection	R	0 – 11	See FIGURE 2-2
97	Units of Measure	R	0 – 4	See FIGURE 2-2
98	Rated Pressure	R		
99	Rated Horse Power/Kilowatt	R	0 – 21	See FIGURE 2-2
100	Starter Type	R	0 - 4	See FIGURE 2-2
101	Service Level	R	0 or 1	0=Level 1, 1=Level 2
102	Service Type	R	0 or 1	0=Hours, 1=Months
103	Service Interval	R	0 - 3	3, 6, 9, or 12 months
112	Offline Pressure	R/W	75 - (rated+3)	rated = rated pressure
113	Online Pressure	R/W	65-(offline-10)	offline = offline pressure
114	Mode of Operation	R/W	0 – 2	See FIGURE 2-2
115	Star-Delta Time (seconds)	R	5 – 20	
116	Auto Start/Stop (AS/S) Time (minutes)	R/W	2 – 60	No Write if AS/S is off
117	Auto Start/Stop (AS/S) On/Off	R	0 or 1	0=Off, 1=On
118	Sequence Control On/Off	R	0 or 1	0=Off, 1=On
119	Remote Start/Stop On/Off	R	0 or 1	0=Off, 1=On
120	Solenoid Delta-P	R	0 or 1	0=Off, 1=On
121	Power Out Restart Option (PORO)On/Off	R	0 or 1	0=Off, 1=On
122	PORO Time (seconds)	R/W	10 - 120	No Write if PORO is off
123	Auto Start/Stop Delay Time (seconds)	R/W	0 - 60	
124	Min. Cooler Out Load Temp	R/W	30 - 150	Low Ambient Option
125	Unloaded Stop Time	R/W	10-30t	
126	Low Ambient Option On/Off	R	0 or 1	0=Off, 1=On
127	Contrast	R	0 - 10	
128	Lead/Lag	R/W	0 or 1	0=Off, 1=On
129	Lag Offset	R/W	0 - 10	
130	Max Modulation Pressure	R/W	(Online+10) – (Offline + 7)	
131	Lead/Lag Cycle Length (Hours)	R/W	0 – 750	
132	Scheduled Start (Hour)	R/W	0 – 23	
133	Scheduled Start (Minute)	R/W	0 – 59	

134	Scheduled Stop (Hour)	R/W	0 – 23	
135	Scheduled Stop (Minute)	R/W	0 – 59	
136	Modbus Protocol	R	0 or 1	0=Off, 1=On
137	Modbus Address	R	1 – 247	
138	High Dust Filter	R	0 or 1	0=Off, 1=On
139	Integral Sequencing Lead	R/W	0 – 3	0=Off, 1=On, 2=Always, 3=Never
140	Integral Sequencing Address	R/W	1 – 4	
141	Integral Sequencing Total	R/W	2 – 4	
142	Integral Sequencing Load Delay	R/W	10 – 60	
143	Integral Sequencing Lead Change (Hours)	R/W	0 – 750	
144	Integral Sequencing Lead Change – Day	R/W	0 – 9	See FIGURE 2-2
145	Integral Sequencing Lead Change – Hour	R/W	0 – 23	
146	Integral Sequencing Lead Change – Min	R/W	0 - 45	Steps of 0, 15, 30, 45
147	Separator Delta-P Sensor	R	0 or 1	0=Off, 1=On
148	Variable Frequency Drive	R	0 or 1	0=Off, 1=On
149	Scheduled Start (Day)	R/W	0 - 9	See FIGURE 2-2
150	Scheduled Stop (Day)	R/W	0 - 9	See FIGURE 2-2
151	Remote Sensor	R	0 or 1	0=Off, 1=On
250	Options	R		See FIGURE 2-2
251	Unloaded Inlet Vacuum	R		
252	Software Part Number – Most Significant	R		High Digits
253	Software Part Number – Least Significant	R		Low Digits
254	Software Version Number	R		
255	Warning Code	R		See FIGURE 2-4
256-270	Alarm Code History	R		See FIGURE 2-4
272-286	Inlet Vacuum Alarm History	R		
288-302	Sump Pressure Alarm History	R		
304-318	Discharge Pressure Alarm History	R		
320-334	Coolant Temperature Alarm History	R		
336-350	Airend Temperature Alarm History	R		
352-366	Discharge Temperature Alarm History	R		
368-382	Low Ambient Coolant Temp. History	R		Low Ambient Option
384-398	Total Hours Alarm History	R		Less Than 10000 Hours
400-414	10000 Total Hours Alarm History	R		Multiply by 10000
416-430	Loaded Hours Alarm History	R		Less Than 10000 Hours
432-446	10000 Loaded Hours Alarm History	R		Multiply by 10000
448-462	Unloaded Inlet Vacuum Alarm History	R		
464-478	Coolant Pressure Alarm History	R		
480-494	Dry Side Sump Pressure Alarm History	R		
496-510	Remote Pressure Alarm History	R		
512-526	Status Alarm History	R		See FIGURE 2-3
528-542	Real Time Clock Alarm History – Hours	R		
544-558	Real Time Clock Alarm History – Minutes	R		
560-574	Real Time Clock Alarm History – Month	R		
576-590	Real Time Clock Alarm History – Date	R		
592-606	Real Time Clock Alarm History – Year	R		
999	IRI Version Number	R		Reads from IRI only

FIGURE 2-1 REGISTER 40001 STATUS / CONTROL

Bit 0: Host/Local (R/W) 0 = Local 1 = Host	Bit 6: Alarm (R) 0 = No Alarms 1 = Alarms
Bit 1: Run/Stop (R/W) 0 = Stop 1 = Run	Bit 7: Warning (R) 0 = No Warnings 1 = Warnings
Bit 2: Load/Unload (R/W) 0 = Unload 1 = Load	Bit 8: On/Off Line Mode (R) 0 = Not in On/Off Line Mode 1 = On/Off Line Mode
Bit 3: Modulating (R) 0 = Not Modulating 1 = Modulating	Bit 9: Mod/ACS or Mod Only (R) 0 = Not in Mod/ASC Mode 1 = Mod/ASC Mode
Bit 4: Unused	Bits 10-12: Unused
Bit 5: Stopped in Auto Restart (R) 0 = Not Stopped in Auto Restart 1 = Stopped in Auto Restart	Bits 13-15: Unit Type (R) 001 = SSR controller

FIGURE 2-2 REGISTER CODES

<p>Register 096: Language 0 = English 1 = Spanish 2 = Portuguese 3 = French 4 = Italian 5 = Dutch 6 = German 7 = Danish 8 = Norwegian 9 = Swedish 10 = Finnish 11 = Turkish</p>	<p>Register 097: Units of Measure 0 = °F and PSI 1 = °C and PSI 2 = °C and Bar 3 = °C and kPa 4 = °C and kg/cm2</p>
<p>Register 99: Rated Horse Power/Kilowatt 0 = 50hp 1 = 60hp 2 = 75hp 3 = 100hp 4 = 125hp 5 = 150hp 6 = 200hp 7 = 250hp 8 = 300hp 9 = 350hp 10 = 400hp</p>	<p>Register 100: Starter Type 0 = Star-Delta 1 = Full Voltage 2 = Remote Star-Delta 3 = Remote Full Voltage 4 = Soft Starter</p>
<p>Register 114: Mode of Operation 0 = MOD/ACS 1 = On/Off Line 2 = Modulation Only</p>	<p>Register 144: Integral Sequencing Lead Change - Day Register 149: Schedule Start - Day Register 150: Schedule Stop - Day 0 = Sunday 1 = Monday 2 = Tuesday 3 = Wednesday 4 = Thursday 5 = Friday 6 = Saturday 7 = Daily 8 = Weekdays 9 = Weekends</p>
<p>Register 250: Options Bit 0: Power Out Restart and Scheduled Start/Stop 0 = Off 1 = On</p>	

FIGURE 2-3 REGISTER STATUS ALARM HISTORY

<p>Bit 0: Run/Stop (R) 0 = Stop 1 = Run</p>	<p>Bit 4: Stopped Auto Restart (R) 0 = Not Stopped in Auto Restart 1 = Stopped in Auto Restart</p>
<p>Bit 1: On/Off Line Mode (R) 0 = Not in On/Off Line Mode 1 = On/Off Line Mode</p>	<p>Bit 5: Unused</p>
<p>Bit 2: MOD/ACS Mode (R) 0 = Not Modulating 1 = Modulating</p>	<p>Bit 6: Unused</p>
<p>Bit 3: Load/Unload (R) 0 = Unload 1 = Load</p>	<p>Bit 7: Unused</p>

FIGURE 2-4 REGISTER ALARM / WARNING CODES

SSR (SG) Controller	
Code	Description
01	Sensor Failure 1AVPT
02	Sensor Failure 3APT
03	Sensor Failure 4APT
04	Sensor Failure 5CPT (Optional)
05	Sensor Failure 6APT (Optional)
06	Sensor Failure P6 (Spare)
07	Sensor Failure P7 (Spare)
08	Sensor Failure P8 (Spare)
09	Sensor Failure 2CTT
10	Sensor Failure 2ATT
11	Sensor Failure 4ATT
12	Sensor Failure 3CTT (Optional)
13	Sensor Failure T5 (Spare)
14	Sensor Failure T6 (Spare)
15	Sensor Failure T7 (Spare)
16	Sensor Failure T8 (Spare)
17	Starter Fault
18	Motor Overload (Main)
19	Fan Motor Overload
20	Control Power Loss
21	Stepper Limit Switch
22	Check Motor Rotation
23	Check Inlet Control System
25	Remote Stop Failure
26	Remote Start Failure
27	Check Inlet Control
28	Low Unload Sump Pressure
29	High Air Pressure
30	Low Sump Air Pressure
31	High A/E Discharge Temperature
32	Emergency Stop
33	Change Inlet Filter
34	Change Separator Element
35	Change Coolant Filter
36	1AVPT Sensor Error (Calibration)
37	Memory Fault
38	100 Hours/14 Days To Service
39	Service Required
40	Alarm - Service Required
41	Auxiliary 2
42	Auxiliary 1
43	High Line/Sump Differential
44	Communication Failure 1
45	Communication Failure 2
46	Communication Failure 3
47	Communication Failure 4
48	Low Coolant Pressure

TABLE 3 SSR (SE) 15-100HP CONTROLLER

Register (40XXX)	Variable	Read/Write	Range	Notes
1	Status/Control	R/W		See FIGURE 3-1
3	Discharge Pressure	R		
4	Sump Pressure	R		
5	Separator Pressure Drop	R		
6	Airend Temperature	R		
64	Total Hours (hours)	R		
65	Loaded Hours (hours)	R		
96	Language Selection	R		See FIGURE 3-2
97	Units of Measure	R		See FIGURE 3-2
98	Rated Pressure	R		
99	Starter Type	R		See FIGURE 3-2
100	Star-Delta Timer (seconds)	R		
101	Contrast	R		
102	Modulation On/Off (v1.5 or higher)	R	0 or 1	0=Off, 1=On
112	Offline Pressure	R/W	75 - (rated+3)	
113	Online Pressure	R/W	65-(offline-10)	
114	Mode of Operation	R/W	0-2	See FIGURE 3-2
115	Display Timer (seconds)	R/W	10-600	
116	Auto Start/Stop (AS/S) On/Off	R	0 or 1	0=Off, 1=On
117	Auto Start/Stop Time (minutes)	R/W	2-20	No Write if AS/S is off
118	Sequence Control On/Off	R	0 or 1	0=Off, 1=On
119	Remote Start/Stop On/Off	R	0 or 1	0=Off, 1=On
120	Power Out Restart Option(PORO) On/Off	R	0 or 1	0=Off, 1=On
121	PORO Time (seconds)	R/W	10-120	No Write if PORO is off
122	Load Delay Time (seconds)	R/W	0-60	
123	Lead/Lag (v1.5 or higher)	R/W	0 or 1	0=Lead, 1=Lag
124	Lag Offset (v1.5 or higher)	R/W	0-45 psi	
125	Low Ambient Option (v1.6 or higher)	R	0 or 1	0=Off, 1=On
252	Part Number (v1.5 or higher)	R		High 16-bits
253	Part Number (v1.5 or higher)	R		Lower 16-bits
254	Software Version (v1.5 or higher)	R		
255	Warning Code	R		See FIGURE 3-4
256-270	Alarm Code History	R		See FIGURE 3-4
272-286	Discharge Pressure Alarm History	R		
288-302	Sump Pressure Alarm History	R		
304-318	Airend Temperature Alarm History	R		
320-334	Separator Pressure Alarm History	R		
336-350	Run Hours Alarm History	R		
352-366	Load Hours Alarm History	R		
368-382	Status Alarm History	R		See FIGURE 3-3
999	IRI Version Number	R		Reads from IRI only

FIGURE 3-1 REGISTER 40001 STATUS / CONTROL

<p>Bit 0: Host/Local (R/W) 0 = Local 1 = Host</p> <p>Bit 1: Run/Stop (R/W) 0 = Stop 1 = Run</p> <p>Bit 2: Load/Unload (R/W) 0 = Unload 1 = Load</p> <p>Bit 3: Modulating (R) 0 = Not Modulating 1 = Modulating</p> <p>Bit 4: Sump Pressure (R/W) 1 = Get Sump Pressure</p> <p>Bit 5: Stopped in Auto Restart (R) 0 = Not Stopped in Auto Restart 1 = Stopped in Auto Restart</p>	<p>Bit 6: Alarm (R) 0 = No Alarms 1 = Alarms</p> <p>Bit 7: Warning (R) 0 = No Warnings 1 = Warnings</p> <p>Bit 8: On/Off Line Mode (R) 0 = Not in On/Off Line Mode 1 = On/Off Line Mode</p> <p>Bit 9: Mod/ACS or Mod Only (R) 0 = Not in Mod/ASC or Mode 1 = Mod/ASC or Mod Mode</p> <p>Bits 10-12: Unused</p> <p>Bits 13-15: Unit Type (R) 010 = SE controller</p>
---	--

FIGURE 3-2 REGISTER CODES

<p>Register 096: Language 0 = English 1 = Spanish 2 = French 3 = Portuguese</p> <p>Register 099: Starter Type 0 = Full Voltage 1 = Star-Delta 2 = No Starter</p>	<p>Register 097: Units of Measure 0 = °C and Bar 1 = °C and PSI 2 = °C and kPa 3 = °F and PSI 4 = °C and kg/cm2</p> <p>Register 114: Mode of Operation 0 = MOD/ACS 1 = Modulation Only 2 = On/Off Line</p>
---	--

FIGURE 3-3 REGISTER STATUS ALARM HISTORY

<p>Bit 0: Run/Stop (R) 0 = Stop 1 = Run</p> <p>Bit 1: On/Off Line Mode (R) 0 = Not in On/Off Line Mode 1 = On/Off Line Mode</p> <p>Bit 2: MOD/ACS Mode (R) 0 = Not Modulating 1 = Modulating</p> <p>Bit 3: Load/Unload (R) 0 = Unload 1 = Load</p>	<p>Bit 4: Stopped Auto Restart (R) 0 = Not Stopped in Auto Restart 1 = Stopped in Auto Restart</p> <p>Bit 5: Unused</p> <p>Bit 6: Unused</p> <p>Bit 7: Unused</p>
--	---

FIGURE 3-4 REGISTER ALARM / WARNING CODES

SSR (SE) 15-100HP CONTROLLER	
Code	Description
01	Pressure Sensor Failure
02	Temperature Sensor Failure 1
04	Starter Fault
05	Motor Overload
06	Reverse Rotation
07	Remote Stop Failure
08	Remote Start Failure
09	Calibration Error
10	High Airend Discharge Temperature
12	High Pressure
15	Separator Element
16	Control Power Loss
17	Fan Motor Overload
18	Emergency Stop
19	Low Sump Pressure
20	Memory Fault
21	Low Unloaded Sump Pressure

TABLE 4 SIERRA (REDEYE) 125-200 HP CONTROLLER

Register (40XXX)	Variable	Read/Write	Range	Notes
1	Status/Control	R/W		See FIGURE 4-1
3	Discharge Pressure	R		
4	2nd Stage Inlet Pressure	R		
5	2nd Stage Discharge Pressure	R		
6	Inlet Vacuum	R		
7	Oil Filter In Pressure	R		
8	Bearing Oil Pressure	R		
9	1st Stage Discharge Temp.	R		
10	2nd Stage Inlet Temp.	R		
11	2nd Stage Discharge Temp.	R		
12	Bearing Oil Temp.	R		
13	Package Discharge Temp.	R		
64	Running Hours (<10,000 hours)	R		
65	Ten Thousand Running Hours	R		Multiply value by 10,000
66	Load Hours (<10,000 hours)	R		
67	Ten Thousand Load Hours	R		Multiply value by 10,000
96	Language Selection	R		See FIGURE 4-2
97	Units of Measure	R		See FIGURE 4-2
98	Rated Pressure	R		
112	Offline Pressure	R/W	75 - (rated+3)	rated = rated pressure
113	Online Pressure	R/W	65-(offline-10)	offline = offline pressure
114	Display Timer (seconds)	R/W	10-600	
115	Condensate Time (seconds)	R/W	90-270	
116	Start-Delta Time (seconds)	R	10-20	
117	Auto Start/Stop Time (seconds)	R/W	2-60	No Write if AS/S is off
118	Max. 1st Stage Temperature	R/W	310-410	
119	Max. 2nd Stage Temperature	R/W	Variable	Refer to Sierra's Manual
120	PORO Time (seconds)	R/W	10-120	No Write if PORO is off
121	Auto Start/Stop On/Off	R	0 or 1	0=Off, 1=On
122	PORO On/Off	R	0 or 1	0=Off, 1=On
123	Remote Start/Stop On/Off	R	0 or 1	0=Off, 1=On
124	Sequence Control On/Off	R	0 or 1	0=Off, 1=On
125	Condensate Level On/Off	R	0 or 1	0=Off, 1=On
126	Water Unit Yes/No	R	0 or 1	0=No, 1=Yes
255	Warning Code	R		See FIGURE 4-4
256-270	Alarm Code History	R		See FIGURE 4-4
272-286	Inlet Vacuum Alarm History	R		
288-302	2nd Stage Inlet Pressure Alarm History	R		
304-318	2nd Stage Discharge Press. Alarm History	R		
320-334	Package Discharge Press. Alarm History	R		
336-350	Oil Filter In Pressure Alarm History	R		
352-366	Bearing Oil Pressure Alarm History	R		
368-382	1st Stage Discharge Temp Alarm History	R		
384-398	2nd Stage Inlet Temp Alarm History	R		
400-414	2nd Stage Discharge Temp Alarm History	R		
512-526	Bearing Oil Temp Alarm History	R		
528-542	Package Discharge Air Temp Alarm History	R		
544-558	Run Hours Alarm History	R		
560-574	Run Hours, Ten Thousand, Alarm History	R		
576-590	Load Hours Alarm History	R		
592-606	Load Hours, Ten Thousand, Alarm History	R		
608-622	Status Alarm History	R		See FIGURE 4-3
999	IRI Version Number	R		Reads from IRI only

FIGURE 4-1 REGISTER 40001 STATUS / CONTROL

Bit 0: Host/Local (R/W) 0 = Local 1 = Host	Bit 6: Alarm (R) 0 = No Alarms 1 = Alarms
Bit 1: Run/Stop (R/W) 0 = Stop 1 = Run	Bit 7: Warning (R) 0 = No Warnings 1 = Warnings
Bit 2: Load/Unload (R/W) 0 = Unload 1 = Load	Bit 8: On/Off Line Mode (R) 0 = Not in On/Off Line Mode 1 = On/Off Line Mode
Bit 3: Unused	Bit 9: Unused
Bit 4: Unused	Bits 10-12: Unused
Bit 6: Stopped in Auto Restart (R) 0 = Not Stopped in Auto Restart 1 = Stopped in Auto Restart	Bits 13-15: Unit Type (R) 100 = Sierra controller

FIGURE 4-2 REGISTER CODES

Register 96: Language 0 = English 1 = Spanish 2 = Portuguese	Register 97: Units of Measure 0 = °F and PSI 1 = °C and PSI 2 = °C and Bar 3 = °C and kPa 4 = °C and kg/cm ²
--	---

FIGURE 4-3 REGISTER STATUS ALARM HISTORY

Bit 0: Run/Stop (R) 0 = Stop 1 = Run	Bit 4: Stopped Auto Restart (R) 0 = Not Stopped in Auto Restart 1 = Stopped in Auto Restart
Bit 1: On/Off Line Mode (R) 0 = Not in On/Off Line Mode 1 = On/Off Line Mode	Bit 5: Unused
Bit 2: Unused	Bit 6: Unused
Bit 3: Load/Unload (R) 0 = Unload 1 = Load	Bit 7: Unused

FIGURE 4-4 REGISTER ALARM / WARNING CODES

SIERRA (REDEYE) 125-200 HP CONTROLLER	
Code	Description
01	Sensor Failure 1AVPT
02	Sensor Failure 2APT
03	Sensor Failure 3APT
04	Sensor Failure 4APT
05	Sensor Failure 5OPT
06	Sensor Failure 6OPT
07	Sensor Failure P7 (Spare)
08	Sensor Failure P8 (Spare)
09	Sensor Failure 2ATT
10	Sensor Failure 3ATT
11	Sensor Failure 4ATT
12	Sensor Failure 5OTT
13	Sensor Failure 7ATT
14	Sensor Failure T6 (Spare)
15	Sensor Failure T7 (Spare)
16	Sensor Failure T8 (Spare)
17	Starter Fault
18	Motor Overload (Main)
19	Fan Motor Overload
20	High 1st Stage Discharge Temp.
21	High 2nd Stage Discharge Temp.
22	High Bearing Oil Temp.
23	High I/C Air Temp.
24	Unused
25	Remote Stop Failure
26	Remote Start Failure
27	High Vacuum
28	High Loaded Vacuum
29	High Discharge Air Pressure
30	Low Bearing Oil Pressure
31	High I/C Pressure (Loaded)
32	Emergency Stop
33	Change Inlet Filter
34	High I/C Pressure (Unloaded)
35	Change Coolant Filter
36	High 2nd Stage Pressure
37	Memory Fault
38	Low Water Flow
39	High Condensate

TABLE 5 SIERRA (SE) 50-100 HP CONTROLLER

Register (40XXX)	Variable	Read/Write	Range	Notes
1	Status/Control	R/W		See FIGURE 5-1
3	Discharge Pressure	R		
4	Package Discharge Temp.	R		
5	Bearing Oil Temp.	R		
6	2nd Stage Inlet Temp.	R		
7	2nd State Discharge Temp.	R		
8	1st Stage Discharge Temp.	R		
64	Total Hours (hours)	R		
65	Loaded Hours (hours)	R		
96	Language Selection	R		See FIGURE 5-2
97	Units of Measure	R		See FIGURE 5-2
98	Rated Pressure	R		
99	Starter Type	R		See FIGURE 5-2
100	Star-Delta Timer (seconds)	R		
101	Contrast	R		
112	Offline Pressure	R/W	75 - (rated+3)	
113	Online Pressure	R/W	65-(offline-10)	
114	Display Timer (seconds)	R/W	10-600	
115	Auto Start/Stop On/Off	R	0 or 1	0=Off, 1=On
116	Auto Start/Stop Time (minutes)	R/W	2-60	No Write if AS/S is off
117	Condensate Switch On/Off	R	0 or 1	0=Off, 1=On
118	Sequence Control On/Off	R	0 or 1	0=Off, 1=On
119	Remote Start/Stop On/Off	R	0 or 1	0=Off, 1=On
120	PORO On/Off	R	0 or 1	0=Off, 1=On
121	PORO Time (seconds)	R/W	10-120	No Write if PORO is off
122	Load Delay Time (seconds)	R/W	0-60	
123	Lead/Lag	R/W	0 or 1	0=Lead, 1=Lag
124	Lag Offset	R/W	0-45 psi	
125	Condensate Discharge Time (seconds)	R/W	2-10	
126	Condensate Interval Time (seconds)	R/W	90-270	
252	Part Number	R		High 16-bits
253	Part Number	R		Lower 16-bits
254	Software Version	R		
255	Warning Code	R		See FIGURE 5-4
256-270	Alarm Code History	R		See FIGURE 5-4
272-286	Discharge Pressure Alarm History	R		
288-302	Package Disch. Temp. Alarm History	R		
304-318	Bearing Oil Temp. Alarm History	R		
320-334	2nd Stage Inlet Temp. Alarm History	R		
336-350	2nd Stage Disch. Temp. Alarm History	R		
352-366	1st Stage Disch. Temp. Alarm History	R		
368-382	Run Hours Alarm History	R		
384-398	Load Hours Alarm History	R		
400-414	Status Alarm History	R		See FIGURE 5-3
999	IRI Version Number	R		Reads from IRI only

FIGURE 5-1 REGISTER 40001 STATUS / CONTROL

Bit 0: Host/Local (R/W) 0 = Local 1 = Host	Bit 6: Alarm (R) 0 = No Alarms 1 = Alarms
Bit 1: Run/Stop (R/W) 0 = Stop 1 = Run	Bit 7: Warning (R) 0 = No Warnings 1 = Warnings
Bit 2: Load/Unload (R/W) 0 = Unload 1 = Load	Bit 8: On/Off Line Mode (R) 0 = Not in On/Off Line Mode 1 = On/Off Line Mode
Bit 3: Unused	Bit 9: Unused
Bit 4: Sump Pressure (R/W) 1 = Get Sump Pressure	Bits 10-12: Unused
Bit 5: Stopped in Auto Restart (R) 0 = Not Stopped in Auto Restart 1 = Stopped in Auto Restart	Bits 13-15: Unit Type (R) 110 = Sierra SE controller

FIGURE 5-2 REGISTER CODES

Register 096: Language 0 = English 1 = Spanish 2 = French 3 = Portuguese	Register 097: Units of Measure 0 = °C and Bar 1 = °C and PSI 2 = °C and kPa 3 = °F and PSI 4 = °C and kg/cm2
Register 099: Starter Type 0 = Full Voltage 1 = Star-Delta 2 = No Starter	

FIGURE 5-3 REGISTER STATUS ALARM HISTORY

Bit 0: Run/Stop (R) 0 = Stop 1 = Run	Bit 4: Stopped Auto Restart (R) 0 = Not Stopped in Auto Restart 1 = Stopped in Auto Restart
Bit 1: On/Off Line Mode (R) 0 = Not in On/Off Line Mode 1 = On/Off Line Mode	Bit 5: Unused
Bit 2: Unused	Bit 6: Unused
Bit 3: Load/Unload (R) 0 = Unload 1 = Load	Bit 7: Unused

FIGURE 5-4 REGISTER ALARM / WARNING CODES

SIERRA (SE) 50-100 HP CONTROLLER	
Code	Description
01	Pressure Sensor Failure
02	Package Disch. Temp. Sensor Failure
03	Bearing Oil Temp. Sensor Failure
04	Starter Fault
05	Motor Overload
06	2nd Stage Inlet Temp. Sensor Failure
07	Remote Stop Failure
08	Remote Start Failure
09	Calibration Error
10	2nd Stage Disch. Temp. Sensor Failure
11	1st Stage Disch. Temp. Sensor Failure
12	High Pressure
13	Oil Pressure Switch
14	Condensate Level
15	High Package Disch. Temp.
16	Control Power Loss
17	High Bearing Oil Temp.
18	Emergency Stop
19	High 2nd Stage Inlet Temp.
20	Memory Fault
21	High 1st Stage Disch. Temp.
22	High 2nd Stage Disch. Temp.

TABLE 6 SIERRA (SG) 125-400 HP CONTROLLER

Register (40XXX)	Variable	Read/Write	Range	Notes
1	Status/Control	R/W		See FIGURE 6-1
3	Discharge Pressure	R		
4	2nd Stage Inlet Pressure	R		
5	2nd Stage Discharge Pressure	R		
6	Inlet Vacuum	R		Value Divided by 10
7	Oil Filter In Pressure	R		
8	Bearing Oil Pressure	R		
9	2nd Stage Inlet Temp	R		
10	1st Stage Discharge Temp.	R		
11	2nd Stage Discharge Temp.	R		
12	Bearing Oil Temp.	R		
13	Package Discharge Temp.	R		
14	P6 Spare Pressure Input	R	0 - 1023	0 volts = 0, 5 volts = 1023
64	Running Hours (<10,000 hours)	R		
65	Ten Thousand Running Hours	R		Multiply value by 10,000
66	Load Hours (<10,000 hours)	R		
67	Ten Thousand Load Hours	R		Multiply value by 10,000
93	Service Level	R	0 or 1	0=Level 1, 1=Level 1
94	Service Type	R	0 or 1	0=Hours, 1=Months
95	Service Interval	R	0 - 3	3, 6, 9, or 12 months
96	Language Selection	R		See FIGURE 6-2
97	Units of Measure	R		See FIGURE 6-2
98	Rating Pressure	R		
99	Starter Type	R	0 - 3	See FIGURE 6-2
100	Power Type	R	0 - 1	0=50 Hz, 1=60 Hz
112	Offline Pressure	R/W	75 - (rated+3)	rated = rated pressure
113	Online Pressure	R/W	65-(offline-10)	offline = offline pressure
114	Condensate Release Time (seconds)	R/W	2-10	
115	Condensate Interval Time (seconds)	R/W	90-270	
116	Start-Delta Time (seconds)	R	10-20	
117	Auto Start/Stop Time (minutes)	R/W	2-60	No Write if AS/S is off
118	Max. 1st Stage Temperature	R/W	310-410	
119	Max. 2nd Stage Temperature	R/W	Variable	Refer to Sierra's Manual
120	PORO Time (seconds)	R/W	10-120	No Write if PORO is off
121	Auto Start/Stop On	R	1	Always On
122	PORO On/Off	R	0 or 1	0=Off, 1=On
123	Remote Start/Stop On/Off	R	0 or 1	0=Off, 1=On
124	Sequence Control On/Off	R	0 or 1	0=Off, 1=On
125	Condensate Level On/Off	R	0 or 1	0=Off, 1=On
126	Load Delay Time (seconds)	R/W	0 - 60	
127	Lead/Lag	R/W	0 or 1	0=Lead, 1=Lag
128	Lag Offset	R/W	0 - 45 psi	
129	Contrast	R	0 - 10	
130	Lead/Lag Cycle Length (Hours)	R/W	0 - 750	
131	Scheduled Start (Hours)	R/W	0 - 23	
132	Scheduled Start (Minutes)	R/W	0 - 59	
133	Scheduled Stop (Hours)	R/W	0 - 23	
134	Scheduled Stop (Minutes)	R/W	0 - 59	
135	Real Time Hours	R	0 - 23	
136	Real Time Minutes	R	0 - 59	
137	Month of Year	R	1-12	
138	Day of Month	R	1-31	
139	Year	R	0 - 99	
140	Integral Sequencing Lead	R/W	0 - 3	0=Off, 1=On, 2=Always, 3=Never
141	Integral Sequencing Total	R/W	2 - 4	
142	Integral Sequencing Address	R/W	1 - 4	

143	Integral Sequencing Load Delay	R/W	10 – 60	
144	Integral Sequencing Lead Change (Hours)	R/W	0 – 750	
145	Integral Sequencing Lead Change – Day	R/W	0 – 9	See FIGURE 6-2
146	Integral Sequencing Lead Change - Hour	R/W	0 – 23	
147	Integral Sequencing Lead Change – Min	R/W	0 – 45	Steps of 0, 15, 30, 45
148	Scheduled Start - Day	R/W	0 – 9	See FIGURE 6-2
149	Scheduled Stop - Day	R/W	0 – 9	See FIGURE 6-2
150	High Dust Filter	R	0 or 1	0=Off, 1=On
252	Part Number	R		High 16-bits
253	Part Number	R		Lower 16-bits
254	Software Version	R		
255	Warning Code	R		See FIGURE 6-4
256-270	Alarm Code History	R		See FIGURE 6-4
272-286	Inlet Vacuum Alarm History	R		
288-302	2nd Stage Inlet Pressure Alarm History	R		
304-318	2nd Stage Discharge Press. Alarm History	R		
320-334	Package Discharge Press. Alarm History	R		
336-350	Oil Filter In Pressure Alarm History	R		
352-366	Bearing Oil Pressure Alarm History	R		
368-382	1st Stage Discharge Temp Alarm History	R		
384-398	2nd Stage Inlet Temp Alarm History	R		
400-414	2nd Stage Discharge Temp Alarm History	R		
512-526	Bearing Oil Temp Alarm History	R		
528-542	Package Discharge Air Temp Alarm History	R		
544-558	Run Hours Alarm History	R		
560-574	Run Hours, Ten Thousand, Alarm History	R		
576-590	Load Hours Alarm History	R		
592-606	Load Hours, Ten Thousand, Alarm History	R		
608-622	Status Alarm History	R		See FIGURE 6-4
999	IRI Version Number	R		Reads from IRI only

FIGURE 6-1 REGISTER 40001 STATUS / CONTROL

Bit 0: Host/Local (R/W) 0 = Local 1 = Host	Bit 6: Alarm (R) 0 = No Alarms 1 = Alarms
Bit 1: Run/Stop (R/W) 0 = Stop 1 = Run	Bit 7: Warning (R) 0 = No Warnings 1 = Warnings
Bit 2: Load/Unload (R/W) 0 = Unload 1 = Load	Bit 8: On/Off Line Mode (R) 0 = Not in On/Off Line Mode 1 = On/Off Line Mode
Bit 3: Unused	Bit 9: Unused
Bit 4: Unused	Bits 10-12: Unused
Bit 5: Stopped in Auto Restart (R) 0 = Not Stopped in Auto Restart 1 = Stopped in Auto Restart	Bits 13-15: Unit Type (R) 100 = Sierra controller

FIGURE 6-2 REGISTER CODES

Register 096: Language 0 = English 1 = Spanish 2 = Portuguese 3 = French 4 = Italian 5 = Dutch	6 = German 7 = Danish 8 = Norwegian 9 = Swedish 10 = Finnish 11 = Turkish	Register 097: Units of Measure 0 = °F and PSI 1 = °C and PSI 2 = °C and Bar 3 = °C and kPa 4 = °C and kg/cm2
Register 099: Starter Type 0 = Star-Delta 1 = Full Voltage 2 = Remote Star-Delta 3 = Remote Full Voltage 4 = Soft Starter		Register 145: Integral Sequencing Lead Change - Day Register 148: Schedule Start - Day Register 149: Schedule Stop - Day 0 = Sunday 1 = Monday 2 = Tuesday 3 = Wednesday 4 = Thursday 5 = Friday 6 = Saturday 7 = Daily 8 = Weekdays 9 = Weekends

FIGURE 6-3 REGISTER STATUS ALARM HISTORY

Bit 0: Run/Stop (R) 0 = Stop 1 = Run	Bit 4: Stopped Auto Restart (R) 0 = Not Stopped in Auto Restart 1 = Stopped in Auto Restart
Bit 1: On/Off Line Mode (R) 0 = Not in On/Off Line Mode 1 = On/Off Line Mode	Bit 5: Unused
Bit 2: Unused	Bit 6: Unused
Bit 3: Load/Unload (R) 0 = Unload 1 = Load	Bit 7: Unused

FIGURE 6-4 REGISTER ALARM / WARNING CODES

SIERRA (SG) 125-400 HP CONTROLLER	
Code	Description
01	Sensor Failure 1AVPT
02	Sensor Failure 2APT
03	Sensor Failure 3APT
04	Sensor Failure 4APT
05	Sensor Failure 5OPT
06	Sensor Failure 6OPT
07	Sensor Failure P7 (Spare)
08	Sensor Failure P8 (Spare)
09	Sensor Failure 2ATT
10	Sensor Failure 3ATT
11	Sensor Failure 4ATT
12	Sensor Failure 5OTT
13	Sensor Failure 7ATT
14	Sensor Failure T6 (Spare)
15	Sensor Failure T7 (Spare)
16	Sensor Failure T8 (Spare)
17	Starter Fault
18	Motor Overload (Main)
19	Fan Motor Overload
20	High 1st Stage Discharge Temp.
21	High 2nd Stage Discharge Temp.
22	High Bearing Oil Temp.
23	High I/C Air Temp.
24	2nd Stage Over Ratio
25	Remote Stop Failure
26	Remote Start Failure
27	High Vacuum
28	High Loaded Vacuum
29	High Discharge Air Pressure
30	Low Bearing Oil Pressure
31	High I/C Pressure (Loaded)
32	Emergency Stop
33	Change Inlet Filter/Inlet Restriction
34	High I/C Pressure (Unloaded)
35	Change Coolant Filter
36	High 2nd Stage Pressure
37	Memory Fault
38	Low Water Flow
39	High Condensate
40	Auxiliary 1
41	Auxiliary 2
42	Service Required
43	100 Hours To Service
44	14 Days To Service
45	Alarm Service Required
46	No Control Power
47	Invalid Calibration
48	Communication Failure 1
49	Communication Failure 2
50	Communication Failure 3
51	Communication Failure 4

TABLE 7 SSR (SG) CONTACT COOLED RETROFIT CONTROLLER

Register (40XXX)	Variable	Read/Write	Range	Notes
1	Status/Control	R/W		See FIGURE 7-1
3	Discharge Pressure	R		
4	Sump Pressure	R		
5	Dry Side Sump Pressure	R		
6	Coolant Temperature	R		
7	Airend Temperature	R		
8	Discharge Temperature	R		
9	Low Ambient Coolant Temp.	R		Low Ambient Option
10	Separator Pressure Drop	R		
11	Spare Pressure Input 4	R		
12	Spare Pressure Input 5	R		
13	Spare Pressure Input 6	R		
14	Spare Pressure Input 7	R		
15	Spare Pressure Input 8	R		
16	Spare Temperature Input 5	R		
17	Spare Temperature Input 6	R		
18	Spare Temperature Input 7	R		
19	Spare Temperature Input 8	R		
64	Total Hours (hours)	R	0 – 9999	Less Than 10000
65	Loaded Hours (hours)	R	0 – 9999	Less Than 10000
66	Ten Thousand Total Hours	R		Multiply by 10000
67	Ten Thousand Loaded Hours	R		Multiply by 10000
96	Language Selection	R	0 – 11	See FIGURE 7-2
97	Units of Measure	R	0 – 4	See FIGURE 7-2
98	Rated Pressure	R		
99	Starter Type	R	0 - 4	See FIGURE 7-2
100	Service Level	R	0 or 1	0=Level 1, 1=Level 2
101	Service Type	R	0 or 1	0=Hours, 1=Months
102	Service Interval	R	0 - 3	3, 6, 9, or 12 months
112	Offline Pressure	R/W	75 - (rated+3)	rated = rated pressure
113	Online Pressure	R/W	65-(offline-10)	offline = offline pressure
114	Mode of Operation	R/W	0 – 2	See FIGURE 7-2
115	Star-Delta Time (seconds)	R	5 – 20	
116	Auto Start/Stop (AS/S) Time (minutes)	R/W	2 – 60	No Write if AS/S is off
117	Auto Start/Stop (AS/S) On/Off	R	0 or 1	0=Off, 1=On
118	Sequence Control On/Off	R	0 or 1	0=Off, 1=On
119	Remote Start/Stop On/Off	R	0 or 1	0=Off, 1=On
120	Unused			
121	Power Out Restart Option (PORO)On/Off	R	0 or 1	0=Off, 1=On
122	PORO Time (seconds)	R/W	10 - 120	No Write if PORO is off
123	Auto Start/Stop Delay Time (seconds)	R/W	0 - 60	
124	Min. Cooler Out Load Temp	R/W	30 - 150	Low Ambient Option
125	Unloaded Stop Time	R/W	10-30	
126	Low Ambient Option On/Off	R	0 or 1	0=Off, 1=On
127	Contrast	R	0 - 10	
128	Lead/Lag	R/W	0 or 1	0=Off, 1=On
129	Lag Offset	R/W	0 - 10	
130	Unused			
131	Lead/Lag Cycle Length (Hours)	R/W	0 – 750	
132	Scheduled Start (Hour)	R/W	0 – 23	
133	Scheduled Start (Minute)	R/W	0 – 59	
134	Scheduled Stop (Hour)	R/W	0 – 23	
135	Scheduled Stop (Minute)	R/W	0 – 59	
136	Modbus Protocol	R	0 or 1	0=Off, 1=On
137	Modbus Address	R	1 – 247	
138	Unused			

139	Integral Sequencing Lead	R/W	0 – 3	0=Off, 1=On, 2=Always, 3=Never
140	Integral Sequencing Address	R/W	1 – 4	
141	Integral Sequencing Total	R/W	2 – 4	
142	Integral Sequencing Load Delay	R/W	10 – 60	
143	Integral Sequencing Lead Change (Hours)	R/W	0 – 750	
144	Integral Sequencing Lead Change – Day	R/W	0 – 9	See FIGURE 7-2
145	Integral Sequencing Lead Change – Hour	R/W	0 – 23	
146	Integral Sequencing Lead Change – Min	R/W	0 - 45	Steps of 0, 15, 30, 45
147	Scheduled Start - Day	R/W	0 – 9	See FIGURE 7-2
148	Scheduled Stop - Day	R/W	0 – 9	See FIGURE 7-2
250	Options	R		See FIGURE 7-2
251	Unused			
252	Software Part Number – Most Significant	R		High Digits
253	Software Part Number – Least Significant	R		Low Digits
254	Software Version Number	R		
255	Warning Code	R		See FIGURE 7-4
256-270	Alarm Code History	R		See FIGURE 7-4
272-286	Unused			
288-302	Sump Pressure Alarm History	R		
304-318	Discharge Pressure Alarm History	R		
320-334	Coolant Temperature Alarm History	R		
336-350	Airend Temperature Alarm History	R		
352-366	Discharge Temperature Alarm History	R		
368-382	Low Ambient Coolant Temp. History	R		Low Ambient Option
384-398	Total Hours Alarm History	R		Less Than 10000 Hours
400-414	10000 Total Hours Alarm History	R		Multiply by 10000
416-430	Loaded Hours Alarm History	R		Less Than 10000 Hours
432-446	10000 Loaded Hours Alarm History	R		Multiply by 10000
448-462	Unused			
464-478	Unused			
480-494	Dry Side Sump Pressure Alarm History	R		
512-526	Status Alarm History	R		See FIGURE 7-3
528-542	Real Time Clock Alarm History – Hours	R		
544-558	Real Time Clock Alarm History – Minutes	R		
560-574	Real Time Clock Alarm History – Month	R		
576-590	Real Time Clock Alarm History – Date	R		
592-606	Real Time Clock Alarm History – Year	R		
999	IRI Version Number	R		Reads from IRI only

FIGURE 7-1 REGISTER 40001 STATUS / CONTROL

Bit 0: Host/Local (R/W) 0 = Local 1 = Host	Bit 6: Alarm (R) 0 = No Alarms 1 = Alarms
Bit 1: Run/Stop (R/W) 0 = Stop 1 = Run	Bit 7: Warning (R) 0 = No Warnings 1 = Warnings
Bit 2: Load/Unload (R/W) 0 = Unload 1 = Load	Bit 8: On/Off Line Mode (R) 0 = Not in On/Off Line Mode 1 = On/Off Line Mode
Bit 3: Modulating (R) 0 = Not Modulating 1 = Modulating	Bit 9: Mod/ACS or Mod Only (R) 0 = Not in Mod/ASC Mode 1 = Mod/ASC Mode
Bit 4: Unused	Bits 10-12: Unused
Bit 5: Stopped in Auto Restart (R) 0 = Not Stopped in Auto Restart 1 = Stopped in Auto Restart	Bits 13-15: Unit Type (R) 001 = SSR controller

FIGURE 7-2 REGISTER CODES

Register 096: Language 0 = English 1 = Spanish 2 = Portuguese 3 = French 4 = Italian 5 = Dutch	6 = German 7 = Danish 8 = Norwegian 9 = Swedish 10 = Finnish 11 = Turkish	Register 097: Units of Measure 0 = °F and PSI 1 = °C and PSI 2 = °C and Bar 3 = °C and kPa 4 = °C and kg/cm2
Register 100: Starter Type 0 = Star-Delta 1 = Full Voltage 2 = Remote Star-Delta 3 = Remote Full Voltage 4 = Soft Starter	Register 114: Mode of Operation 0 = MOD/ACS 1 = On/Off Line 2 = Modulation Only	
Register 144: Integral Sequencing Lead Change - Day		
Register 147: Schedule Start - Day		
Register 148: Schedule Stop - Day 0 = Sunday 1 = Monday 2 = Tuesday 3 = Wednesday 4 = Thursday 5 = Friday 6 = Saturday 7 = Daily 8 = Weekdays 9 = Weekends		
Register 250: Options Bit 0: Power Out Restart and Scheduled Start/Stop 0 = Off 1 = On		

FIGURE 7-3 REGISTER STATUS ALARM HISTORY

Bit 0: Run/Stop (R) 0 = Stop 1 = Run	Bit 4: Stopped Auto Restart (R) 0 = Not Stopped in Auto Restart 1 = Stopped in Auto Restart
Bit 1: On/Off Line Mode (R) 0 = Not in On/Off Line Mode 1 = On/Off Line Mode	Bit 5: Unused
Bit 2: MOD/ACS Mode (R) 0 = Not Modulating 1 = Modulating	Bit 6: Unused
Bit 3: Load/Unload (R) 0 = Unload 1 = Load	Bit 7: Unused

FIGURE 7-4 REGISTER ALARM / WARNING CODES

SSR (SG) CONTACT COOLED RETROFIT CONTROLLER	
Code	Description
01	Sensor Failure 4APT
02	Sensor Failure 3APT
03	Sensor Failure 6APT
04	Sensor Failure P4 (Spare)
05	Sensor Failure P5 (Spare)
06	Sensor Failure P6 (Spare)
07	Sensor Failure P7 (Spare)
08	Sensor Failure P8 (Spare)
09	Sensor Failure 2CTT
10	Sensor Failure 2ATT
11	Sensor Failure 4ATT
12	Sensor Failure 3CTT (Optional)
13	Sensor Failure T5 (Spare)
14	Sensor Failure T6 (Spare)
15	Sensor Failure T7 (Spare)
16	Sensor Failure T8 (Spare)
17	Starter Fault
18	Motor Overload (Main)
19	Fan Motor Overload
20	Control Power Loss
21	Stepper Limit Switch
22	Check Motor Rotation
23	Check Inlet Control System
25	Remote Stop Failure
26	Remote Start Failure
27	Check Inlet Control
28	Low Unload Sump Pressure
29	High Air Pressure
30	Low Sump Air Pressure
31	High A/E Discharge Temperature
32	Emergency Stop
33	Change Inlet Filter
34	Change Separator Element
35	Change Coolant Filter
36	1AVPT Sensor Error (Calibration)
37	Memory Fault
38	100 Hours/14 Days To Service
39	Service Required
40	Alarm - Service Required
41	Auxiliary 2
42	Auxiliary 1
43	High Line/Sump Differential
44	Communication Failure 1
45	Communication Failure 2
46	Communication Failure 3
47	Communication Failure 4

TABLE 8 RECIP (REDEYE) CONTROLLER

Register (40XXX)	Variable	Read/Write	Range	Notes
1	Status/Control	R/W		See FIGURE 8-1
3	1st Stage Discharge Pressure	R		
4	Package Discharge Pressure	R		
5	Air Filter Pressure Drop	R		
6	Frame Oil Pressure	R		
7	Package Water In Pressure	R		
8	Package Water Out Pressure	R		
9	Pressure AA	R		
10	Pressure BB	R		
11	1st Stage Discharge Temp.	R		
12	2nd Stage Discharge Temp.	R		
13	Frame Oil Temperature	R		
14	Package Water In Temp.	R		
15	2nd Stage Air In Temp.	R		
16	1st Stage Water Out Temp.	R		
17	2nd Stage Water Out Temp.	R		
18	Unused	R		
64	Run 10,000 Hours	R		
65	Run Hours (<10,000)	R		
66	Load 10,000 Hours	R		
67	Load Hours (<10,000)	R		
68	Load 75% 10,000 Hours	R		
69	Load 75% Hours (<10,000)	R		
70	Load 50% 10,000 Hours	R		
71	Load 50% Hours (<10,000)	R		
72	Load 25% 10,000 Hours	R		
73	Load 25% Hours (<10,000)	R		
74	Unload 10,000 Hours	R		
75	Unload Hours (<10,000)	R		
96	Rated Pressure	R		
97	Recip Type	R		See FIGURE 8-2
98	Regulation Type	R		See FIGURE 8-2
112	Offline Pressure	R/W	30 - rated	rated=rated pressure
113	Online Pressure	R/W	20-(offline-10)	offline=offline pressure
114	Data View Time	R/W	10-600	
115	Load Delay Time	R/W	15-60	
116	Star-Delta Time	R	3-19	Star-Delta Units Only
117	Auto Start/Stop Time	R/W	10-180	
118	Remote Start/Stop	R	0 or 1	0=Off, 1=On
119	Sequence Control	R	0 or 1	0=Off, 1=On
120	1st Stage Discharge Temp. (Max)	R/W	150-500	
121	2nd Stage Discharge Temp. (Max)	R/W	150-500	
122	Frame Oil Temp. (Max)	R/W	120-210	
123	Frame Oil Temp. Shutdown	R	0 or 1	0=No, 1=Yes
124	Package Water In Temp. (Min)	R/W	25-45	
125	Package Water In Temp. Shutdown	R	0 or 1	0=No, 1=Yes
126	Package Water In Temp. (Max)	R/W	50-150	
127	Package Water In Temp. Shutdown	R	0 or 1	0=No, 1=Yes
128	2nd Stage Air In Temp. (Max)	R/W	80-160	
129	2nd Stage Air In Temp. Shutdown	R	0 or 1	0=No, 1=Yes
130	1st Stage Water Out Temp. (Max)	R/W	80-155	
131	1st Stage Water Out Temp. Shutdown	R	0 or 1	0=No, 1=Yes
132	2nd Stage Water Out Temp. (Max)	R/W	80-155	
133	2nd Stage Water Out Temp Shutdown	R	0 or 1	0=No, 1=Yes
134	Package Discharge Pressure (Max)	R/W	30-X	X=rated + 10% of rated
135	Package Discharge Press. Shutdown	R	0 or 1	0=No, 1=Yes

136	Air Filter Pressure Drop (Max)	R/w	.2-1.0	
137	Frame Oil Pressure (Min)	R/W	8-60	
138	Package Water In Pressure (Max)	R/W	50-76	
139	Package Water In Press. Shutdown	R	0 or 1	0=No, 1=Yes
140	Package Water In Pressure (Min)	R/W	6-40	
141	Package Water In Press. Shutdown	R	0 or 1	0=No, 1=Yes
142	Package Water Pressure Loss (Min)	R/W	0-30	
143	Package Water Press. Loss Shutdown	R	0 or 1	0=No, 1=Yes
144	Pressure AA (Min)	R/W	0-200	
145	Pressure AA Shutdown	R	0 or 1	0=No, 1=Yes
146	Pressure BB (Max)	R/W	0-200	
147	Pressure BB Shutdown	R	0 or 1	0=No, 1=Yes
148	Lubricator Failure Shutdown	R	0 or 1	0=No, 1=Yes
149	Intercooler Condensate Shutdown	R	0 or 1	0=No, 1=Yes
150	Aftercooler Condensate Shutdown	R	0 or 1	0=No, 1=Yes
151	Lubricator Oil Level Shutdown	R	0 or 1	0=No, 1=Yes
152	Frame Oil Level Shutdown	R	0 or 1	0=No, 1=Yes
153	Switch AA Shutdown	R	0 or 1	0=No, 1=Yes
154	Switch BB Shutdown	R	0 or 1	0=No, 1=Yes
155	Condensate Time	R/W	5-60	
156	PORO On/Off	R	0 or 1	0=Off, 1=On
157	PORO Time	R/W	10-120	
255	Warning Code	R		See FIGURE 8-4
256-270	Alarm Code History	R		See FIGURE 8-4
272-286	1st Stage Disch. Press. Alarm History	R		
288-302	Package Disch. Temp. Alarm History	R		
304-318	Air Filter Press. Drop Alarm History	R		
320-334	Frame Oil Press. Alarm History	R		
336-350	Package Water In Press Alarm History	R		
352-366	Package Water Out Press Alarm Hist.	R		
368-382	Pressure AA Alarm History	R		
384-398	Pressure BB Alarm History	R		
400-414	1st Stage Disch. Temp. Alarm History	R		
416-430	2nd Stage Disch. Temp. Alarm History	R		
432-446	Frame Oil Temp. Alarm History	R		
448-462	Package Water In Temp. Alarm Hist.	R		
464-478	2nd Stage Air In Temp. Alarm History	R		
480-494	1st Stage Water Out Temp Alarm Hist.	R		
496-510	2nd Stage Water Out Temp Alarm Hist.	R		
512-526	Run Hours >10,000 Alarm History	R		
528-542	Run Hours <10,000 Alarm History	R		
544-558	100% Load Hours >10,000 Alarm Hist.	R		
560-574	100% Load Hours <10,000 Alarm Hist.	R		
576-590	75% Load Hours >10,000 Alarm Hist.	R		
592-606	75% Load Hours <10,000 Alarm Hist.	R		
608-622	50% Load Hours >10,000 Alarm Hist.	R		
624-638	50% Load Hours <10,000 Alarm Hist.	R		
640-654	25% Load Hours >10,000 Alarm Hist.	R		
656-670	25% Load Hours <10,000 Alarm Hist.	R		
672-686	Unload Hours >10,000 Alarm Hist.	R		
688-702	Unload Hours <10,000 Alarm Hist.	R		
704-718	Status Alarm History	R		See FIGURE 8-3
999	IRI Version Number	R		Reads from IRI only

FIGURE 8-1 REGISTER 40001 STATUS / CONTROL

<p>Bit 0: Host/Local (R/W) 0 = Local 1 = Host</p> <p>Bit 1: Run/Stop (R/W) 0 = Stop 1 = Run</p> <p>Bit 2: Load/Unload (R/W) 0 = Unload 1 = Load</p> <p>Bits 3-4: Load Level (R/W) 00 = 25% 01 = 50% 10 = 75% 11 = 100%</p> <p>Bit 5: Stopped in Auto Restart (R) 0 = Not Stopped in Auto Restart 1 = Stopped in Auto Restart</p>	<p>Bit 6: Alarm (R) 0 = No Alarms 1 = Alarms</p> <p>Bit 7: Warning (R) 0 = No Warnings 1 = Warnings</p> <p>Bit 8: Constant Speed Mode (R) 0 = Not in Const. Speed Mode 1 = Constant Speed Mode</p> <p>Bit 9: Auto/Dual Mode (R) 0 = Not in Auto/Dual Mode 1 = Auto/Dual Mode</p> <p>Bits 10-12: Unused</p> <p>Bits 13-15: Unit Type (R) 111 = Recip controller</p>
---	---

FIGURE 8-2 REGISTER CODES

<p>Register 96: Language 0 = English 1 = Spanish 2 = Portuguese</p>	<p>Register 97: Units of Measure 0 = °F and PSI 1 = °C and PSI 2 = °C and Bar 3 = °C and kPa 4 = °C and kg/cm2</p>
---	--

FIGURE 8-3 REGISTER STATUS ALARM HISTORY

<p>Bit 0: Run/Stop (R) 0 = Stop 1 = Run</p> <p>Bit 1: Constant Speed Mode (R) 0 = Not in Constant Speed Mode 1 = Constant Speed Mode</p> <p>Bit 2: Auto Dual Mode (R) 0 = Not in Auto Dual Mode 1 = Auto Dual Mode</p> <p>Bit 3: Load/Unload (R) 0 = Unload 1 = Load</p>	<p>Bit 4: Stopped Auto Restart (R) 0 = Not Stopped in Auto Restart 1 = Stopped in Auto Restart</p> <p>Bits 5-6: Load Level 00 = 25% Load 01 = 50% Load 10 = 75% Load 11 = 100% Load</p> <p>Bit 7: Unused</p>
--	---

FIGURE 8-4 REGISTER ALARM / WARNING CODES

RECIP (REDEYE) CONTROLLER	
Code	Description
01	1st Stage Disch. Press. Sensor Failure
02	Package Disch. Press. Sensor Failure
03	Air Filter Press. Drop Sensor Failure
04	Frame Oil Press. Sensor Failure
05	Pkg. Water In Press. Sensor Failure
06	Pkg. Water Out Press. Sensor Failure
07	Pressure AA Sensor Failure
08	Pressure BB Sensor Failure
17	1st Stage Disch. Temp. Sensor Failure
18	2nd Stage Disch. Temp. Sensor Failure
19	Frame Oil Temp. Sensor Failure
20	Pkg. Water In Temp. Sensor Failure
21	2nd Stage Air In Temp. Sensor Failure
22	1st Stg. Wtr. Out Temp. Sensor Failure
23	2nd Stg. Wtr. Out Temp. Sensor Failure
33	Emergency Stop
34	Starter Fault
35	Main Motor Overload
36	Motor Not Synchronized
37	Lubricator Failure
38	Intercooler Condensate
39	Aftercooler Condensate
40	Lubricator Oil
41	Frame Oil
42	Switch AA
43	Switch BB
44	Remote Stop Failure
45	Remote Start Failure
46	1st Stage Discharge Temp.
47	2nd Stage Discharge Temp.
48	Frame Oil Temp.
49	Package Water In Temp. (Low)
50	Package Water In Temp. (High).
51	2nd Stage Air In Temp.
52	1st Stage Water Out Temp.
53	2nd Stage Water Out Temp.
61	Package Discharge Pressure
62	Air Filter Pressure Drop
63	Frame Oil Pressure
64	Package Water In Pressure (Low)
65	Package Water In Pressure (High)
66	Package Water Pressure Loss
67	Pressure AA
68	Pressure BB
77	High Disch. Press. caused by host

TABLE 9 RECIP (SG) CONTROLLER

Register (40XXX)	Variable	Read/Write	Range	Notes
1	Status/Control	R/W		See FIGURE 9-1
3	Oil Pressure	R		
4	Water In Pressure	R		
5	Water Out Pressure	R		
6	Package Discharge Pressure	R		
7	1st Stage Discharge Pressure	R		
8	2nd Stage Discharge Pressure	R		3 Stage Units Only
9	Suction Pressure	R		Booster Units Only
10	Inlet Vacuum	R		Air Filter Press Drop Option
11	Oil Temperature	R		
12	Water In Temperature	R		
13	2nd Stage Inlet Temperature	R		
14	3rd Stage Inlet Temperature	R		3 Stage Units Only
15	Package Discharge Temperature	R		
16	1st Stage Discharge Temperature	R		
17	2nd Stage Discharge Temperature	R		
18	3rd Stage Discharge Temperature	R		3 Stage Units Only
64	Total Hours (hours)	R	0 – 9999	Less Than 10000
65	Ten Thousand Total Hours	R		Multiply by 10000
66	100% Loaded Hours (hours)	R	0 – 9999	Less Than 10000
67	Ten Thousand 100% Loaded Hours	R		Multiply by 10000
68	50% Loaded Hours (hours)	R	0 – 9999	Less Than 10000
69	Ten Thousand 50% Loaded Hours	R		Multiply by 10000
70	25% Loaded Hours (hours)	R	0 – 9999	Less Than 10000
71	Ten Thousand 25% Loaded Hours	R		Multiply by 10000
72	75% Loaded Hours (hours)	R	0 – 9999	Less Than 10000
73	Ten Thousand 75% Loaded Hours	R		Multiply by 10000
96	Language Selection	R	0 – 2	See FIGURE 9-2
97	Units of Measure	R	0 – 4	See FIGURE 9-2
98	Recip Type	R	0 – 5	See FIGURE 9-2
99	Rated Pressure	R		
100	Sensor 2APT	R	0 – 2	0=225, 1=500, 2=1000
101	Sensor 1APT	R	0 – 2	0=225, 1=500, 2=1000
102	Sensor 7APT	R	0 – 2	0=225, 1=500, 2=1000
103	Sensor 3APT	R	0 – 2	0=225, 1=500, 2=1000
104	Regulation	R	0 – 4	See FIGURE 9-2
105	Starter Type	R	0 – 3	See FIGURE 9-2
112	Offline Pressure	R/W	30 - rated	rated = rated pressure
113	Online Pressure	R/W	20-(offline-2)	offline = offline pressure
114	Mode of Operation	R/W	0 – 1	See FIGURE 9-2
115	Load Delay Time (seconds)	R/W	15 – 60	
116	Star-Delta Time (seconds)	R	10 – 20	
117	Auto Start/Stop (AS/S) Time (minutes)	R/W	2 – 20	
118	Condensate Time (seconds)	R/W	3 – 60	
119	Contrast	R	0 – 10	
120	Condensate Interval (seconds)	R/W	60 – 300	
121	Inlet Regulation Time (10ths of seconds)	R/W	0 – 5.0	
122	Minimum 1st Stage Discharge Pressure	R/W	50 – 300	
123	Auto Start Delay Time (seconds)	R/W	0 – 60	
128	Remote Start/Stop On/Off	R	0 or 1	0=Off, 1=On
129	Sequence Control On/Off	R	0 or 1	0=Off, 1=On
130	Power Out Restart Option (PORO)On/Off	R	0 or 1	0=Off, 1=On
131	PORO Time (seconds)	R	10 - 120	
132	Air Filter Pressure Drop On/Off	R	0 or 1	0=Off, 1=On
133	Air Filter Pressure Drop Value (10th of psi)	R	.2 – 1.0	
134	Closed Loop Water System	R	0 or 1	0=Off, 1=On

144	High 1st Stage Discharge Temperature	R/W	150 – 500	
145	High 2nd Stage Discharge Temperature	R/W	150 – 500	
146	High 3rd Stage Discharge Temperature	R/W	150 – 500	
147	High Oil Temperature	R/W	120 – 210	
148	Low Water In Temperature	R/W	30 – 50	
149	High Water In Temperature	R/W	50 – 150	
150	High 2nd Stage In Temperature	R/W	80 – 160	
151	High 3rd Stage In Temperature	R/W	80 – 160	
152	High Package Discharge Temperature	R/W	80 – 500	
153	High 1st Stage Discharge Pressure	R/W	100 – 400	
154	High 2nd Stage Discharge Pressure	R/W	100 – 400	
155	Low Suction Pressure	R/W	30 – 400	
156	High Suction Pressure	R/W	35 – 405	
157	Low Oil Pressure	R/W	8 – 60	
158	Low Water In Pressure	R/W	25 – 45	
159	High Water In Pressure	R/W	50 – 76	
160	Low Water Pressure Drop	R/W	0 – 40	
252	Software Part Number – Most Significant	R		High Digits
253	Software Part Number – Least Significant	R		Low Digits
254	Software Version Number	R		
255	Warning Code	R		See FIGURE 9-4
256-270	Alarm Code History	R		See FIGURE 9-4
272-286	Oil Pressure Alarm History	R		
288-302	Water In Pressure Alarm History	R		
304-318	Water Out Pressure Alarm History	R		
320-334	Package Discharge Press Alarm History	R		
336-350	1st Stage Discharge Press Alarm History	R		
352-366	2nd Stage Discharge Press Alarm History	R		
368-382	Suction Pressure Alarm History	R		
384-398	Inlet Vacuum Alarm History	R		
400-414	Oil Temperature Alarm History	R		
416-430	Water In Temperature Alarm History	R		
432-446	2nd Stage In Temperature Alarm History	R		
448-462	3rd Stage In Temperature Alarm History	R		
464-478	Package Discharge Temp Alarm History	R		
480-494	1st Stage Discharge Temp Alarm History	R		
496-510	2nd Stage Discharge Temp Alarm History	R		
512-526	3rd Stage Discharge Temp Alarm History	R		
528-542	Run Hours Alarm History	R		Less Than 10000 Hours
544-558	10000 Run Hours Alarm History	R		Multiply by 10000
560-574	100% Loaded Hours Alarm History	R		Less Than 10000 Hours
576-590	10000 100% Loaded Hours Alarm History	R		Multiply by 10000
592-606	50% Loaded Hours Alarm History	R		Less Than 10000 Hours
608-622	10000 50% Loaded Hours Alarm History	R		Multiply by 10000
624-638	Status Alarm History	R		See FIGURE 9-3
640-654	Real Time Clock Alarm History – Hours	R		
656-670	Real Time Clock Alarm History – Minutes	R		
672-686	Real Time Clock Alarm History – Month	R		
688-702	Real Time Clock Alarm History – Date	R		
704-718	Real Time Clock Alarm History – Year	R		
720-734	25% Loaded Hours Alarm History	R		Less Than 10000 Hours
736-750	10000 25% Loaded Hours Alarm History	R		Multiply by 10000
752-766	75% Loaded Hours Alarm History	R		Less Than 10000 Hours
768-782	10000 75% Loaded Hours Alarm History	R		Multiply by 10000
999	IRI Version Number	R		Reads from IRI only

FIGURE 9-1 REGISTER 40001 STATUS / CONTROL

<p>Bit 0: Host/Local (R/W) 0 = Local 1 = Host</p> <p>Bit 1: Run/Stop (R/W) 0 = Stop 1 = Run</p> <p>Bit 2: Load/Unload (R/W) 0 = Unload 1 = Load</p> <p>Bits 3-4: Load Level (R/W) 00 = 25% 01 = 50% 10 = 75% 11 = 100%</p> <p>Bit 5: Stopped in Auto Restart (R) 0 = Not Stopped in Auto Restart 1 = Stopped in Auto Restart</p>	<p>Bit 6: Alarm (R) 0 = No Alarms 1 = Alarms</p> <p>Bit 7: Warning (R) 0 = No Warnings 1 = Warnings</p> <p>Bit 8: Constant Speed Mode (R) 0 = Not in Const. Speed Mode 1 = Constant Speed Mode</p> <p>Bit 9: Auto/Dual Mode (R) 0 = Not in Auto/Dual Mode 1 = Auto/Dual Mode</p> <p>Bits 10-12: Unused</p> <p>Bits 13-15: Unit Type (R) 111 = Recip controller</p>
---	---

FIGURE 9-2 REGISTER CODES

<p>Register 096: Language 0 = English 1 = Spanish 2 = Portuguese</p> <p>Register 098: Recip Type 0 = ESV 1 = ESV Booster 2 = PHE, LLE, XLE 2 Stage 3 = PHE, DXE 3 Stage 4 = PHE 2 A/E Booster 5 = PHE 2 Stage Booster</p> <p>Register 105: Starter Type 0 = Star-Delta 1 = Full Voltage 2 = Remote Star-Delta 3 = Remote Full Voltage</p>	<p>Register 097: Units of Measure 0 = °F and PSI 1 = °C and PSI 2 = °C and Bar 3 = °C and kPa 4 = °C and kg/cm2</p> <p>Register 104: Regulation 0 = 2 Step 1 = 3 Step 2 = 5 Step 1 3 = 5 Step 2 4 = Inlet Regulation</p> <p>Register 114: Mode of Operation 0 = Constant Speed 1 = Auto/Dual</p>
---	---

FIGURE 9-3 REGISTER STATUS ALARM HISTORY

<p>Bit 0: Run/Stop (R) 0 = Stop 1 = Run</p> <p>Bit 1: Constant Speed Mode (R) 0 = Not in Constant Speed Mode 1 = Constant Speed Mode</p> <p>Bit 2: Auto Dual Mode (R) 0 = Not in Auto Dual Mode 1 = Auto Dual Mode</p> <p>Bit 3: Load/Unload (R) 0 = Unload 1 = Load</p>	<p>Bit 4: Stopped Auto Restart (R) 0 = Not Stopped in Auto Restart 1 = Stopped in Auto Restart</p> <p>Bits 5-6: Load Level 00 = 25% Load 01 = 50% Load 10 = 75% Load 11 = 100% Load</p> <p>Bit 7: Unused</p>
--	---

FIGURE 9-4 REGISTER ALARM / WARNING CODES

RECIP (SG) CONTROLLER	
Code	Description
01	Sensor Failure 1APT
02	Sensor Failure 2APT
03	Sensor Failure 3APT
04	Sensor Failure 4OPT
05	Sensor Failure 5WPT
06	Sensor Failure 6WPT
07	Sensor Failure 7APT
08	Sensor Failure 3AVPT
09	Sensor Failure 3OTT
10	Sensor Failure 7WTT
11	Sensor Failure 5ATT
12	Sensor Failure 6ATT
13	Sensor Failure 4ATT
14	Sensor Failure 1ATT
15	Sensor Failure 2ATT
16	Sensor Failure 8ATT
17	Starter Fault
18	Motor Overload
19	High Vibration
20	Control Power Loss
21	Lubricator Line Alert
22	Low Lubricator Oil Level
23	Low Frame Oil Level
24	Intercooler Condensate
25	Remote Stop Failure
26	Remote Start Failure
27	Aftercooler Condensate
28	High Package Inlet Temperature
29	High Water Out Temperature
30	High Frame Oil Temperature
31	Low Water In Temperature
32	Emergency Stop
33	High 2nd Stage In Temperature
34	High 3rd Stage In Temperature
35	High Package Discharge Temp
36	High 1st Stage Discharge Temp
37	High 2nd Stage Discharge Temp
38	High 3rd Stage Discharge Temp
39	High Water In Temp
40	Low Frame Oil Pressure
41	Low Water In Pressure
42	High Water In Pressure
43	Low Water Pressure Loss
44	High Package Discharge Pressure
45	High 1st Stage Discharge Pressure
46	High 2nd Stage Discharge Pressure
47	Low Suction Pressure
48	High Suction Pressure
49	Air Filter Pressure Drop
50	High Discharge Pressure by Host
51	Motor Not Synchronized
52	Memory Fault
53	Invalid Calibration

TABLE 10 RECIP BOOSTER (REDEYE) CONTROLLER

Register (40XXX)	Variable	Read/Write	Range	Notes
1	Status/Control	R/W		See FIGURE 10-1
3	1st Stage Discharge Pressure	R		
4	Package Discharge Pressure	R		
5	Package Suction Pressure	R		
6	Frame Oil Pressure	R		
7	Package Water In Pressure	R		
8	Package Water Out Pressure	R		
9	Pressure AA	R		
10	Pressure BB	R		
11	1st Stage Discharge Temp.	R		
12	2nd Stage Discharge Temp.	R		
13	Frame Oil Temperature	R		
14	Package Water In Temp.	R		
15	2nd Stage Air In Temp.	R		
16	Package Inlet Air Temp.	R		
17	Package Water Out Temp.	R		
18	Unused	R		
64	Run 10,000 Hours	R		
65	Run Hours (<10,000)	R		
66	Load 10,000 Hours	R		
67	Load Hours (<10,000)	R		
68	Load 75% 10,000 Hours	R		
69	Load 75% Hours (<10,000)	R		
70	Load 50% 10,000 Hours	R		
71	Load 50% Hours (<10,000)	R		
72	Load 25% 10,000 Hours	R		
73	Load 25% Hours (<10,000)	R		
74	Unload 10,000 Hours	R		
75	Unload Hours (<10,000)	R		
96	Rated Pressure	R		
97	Recip Type	R		See FIGURE 10-2
98	Regulation Type	R		See FIGURE 10-2
99	Language	R		See FIGURE 10-2
100	Unit of Measure	R		See FIGURE 10-2
112	Offline Pressure	R/W	30 - rated	rated=rated pressure
113	Online Pressure	R/W	20-(offline-10)	offline=offline pressure
114	Data View Time	R/W	10-600	
115	Load Delay Time	R/W	15-60	
116	Star-Delta Time	R	3-19	Star-Delta Units Only
117	Auto Start/Stop Time	R/W	10-180	
118	Remote Start/Stop	R	0 or 1	0=Off, 1=On
119	Sequence Control	R	0 or 1	0=Off, 1=On
120	1st Stage Discharge Temp. (Max)	R/W	150-500	
121	2nd Stage Discharge Temp. (Max)	R/W	150-500	
122	Frame Oil Temp. (Max)	R/W	120-210	
123	Frame Oil Temp. Shutdown	R	0 or 1	0=No, 1=Yes
124	Package Water In Temp. (Min)	R/W	25-45	
125	Package Water In Temp. Shutdown	R	0 or 1	0=No, 1=Yes
126	Package Water In Temp. (Max)	R/W	50-150	
127	Package Water In Temp. Shutdown	R	0 or 1	0=No, 1=Yes
128	2nd Stage Air In Temp. (Max)	R/W	80-160	
129	2nd Stage Air In Temp. Shutdown	R	0 or 1	0=No, 1=Yes
130	Package Inlet Air Temp. (Max)	R/W	50-200	
131	Package Inlet Air Temp. Shutdown	R	0 or 1	0=No, 1=Yes
132	Package Water Out Temp. (Max)	R/W	80-200	
133	Package Water Out Temp Shutdown	R	0 or 1	0=No, 1=Yes

134	Low 1st Stage Discharge Pressure	R/W	80-320	
135	High 1st Stage Discharge Pressure	R/W	100-400	
136	High 1st Stage Discharge Shutdown	R	0 or 1	0=No, 1=Yes
137	Low Package Discharge Pressure	R/W	15-558	
138	High Package Discharge Pressure	R/W	500-715	
139	High Package Discharge Shutdown	R	0 or 1	0=No, 1=Yes
140	Low Package Suction Pressure	R/W	50-180	
141	High Package Suction Pressure	R/W	50-180	
142	Low Frame Oil Pressure	R/W	8-60	
143	Low Package Water In Pressure	R/W	6-40	
144	Low Pkg Water In Press. Shutdown	R	0 or 1	0=No, 1=Yes
145	High Package Water In Pressure	R/W	50-76	
146	High Pkg Water In Press. Shutdown	R	0 or 1	0=No, 1=Yes
147	Package Water Pressure Loss (Min)	R/W	0-30	
148	Package Water Press. Loss Shutdown	R	0 or 1	0=No, 1=Yes
149	Pressure AA (Min)	R/W	0-200	
150	Pressure AA Shutdown	R	0 or 1	0=No, 1=Yes
151	Pressure BB (Max)	R/W	0-200	
152	Pressure BB Shutdown	R	0 or 1	0=No, 1=Yes
153	Lubricator Failure Shutdown	R	0 or 1	0=No, 1=Yes
154	Intercooler Condensate Shutdown	R	0 or 1	0=No, 1=Yes
155	Aftercooler Condensate Shutdown	R	0 or 1	0=No, 1=Yes
156	Lubricator Oil Level Shutdown	R	0 or 1	0=No, 1=Yes
157	Frame Oil Level Shutdown	R	0 or 1	0=No, 1=Yes
158	Switch AA Shutdown	R	0 or 1	0=No, 1=Yes
159	Switch BB Shutdown	R	0 or 1	0=No, 1=Yes
160	Condensate Time	R/W	5-60	
255	Warning Code	R		See FIGURE 10-4
256-270	Alarm Code History	R		See FIGURE 10-4
272-286	1st Stage Disch. Press. Alarm History	R		
288-302	Package Disch. Temp. Alarm History	R		
304-318	Package Suction Press. Alarm History	R		
320-334	Frame Oil Press. Alarm History	R		
336-350	Package Water In Press Alarm History	R		
352-366	Package Water Out Press Alarm Hist.	R		
368-382	Pressure AA Alarm History	R		
384-398	Pressure BB Alarm History	R		
400-414	1st Stage Disch. Temp. Alarm History	R		
416-430	2nd Stage Disch. Temp. Alarm History	R		
432-446	Frame Oil Temp. Alarm History	R		
448-462	Package Water In Temp. Alarm Hist.	R		
464-478	2nd Stage Air In Temp. Alarm History	R		
480-494	Package Inlet Air Temp Alarm Hist.	R		
496-510	Package Water Out Temp Alarm Hist.	R		
512-526	Run Hours >10,000 Alarm History	R		
528-542	Run Hours <10,000 Alarm History	R		
544-558	100% Load Hours >10,000 Alarm Hist.	R		
560-574	100% Load Hours <10,000 Alarm Hist.	R		
576-590	75% Load Hours >10,000 Alarm Hist.	R		
592-606	75% Load Hours <10,000 Alarm Hist.	R		
608-622	50% Load Hours >10,000 Alarm Hist.	R		
624-638	50% Load Hours <10,000 Alarm Hist.	R		
640-654	25% Load Hours >10,000 Alarm Hist.	R		
656-670	25% Load Hours <10,000 Alarm Hist.	R		
672-686	Unload Hours >10,000 Alarm Hist.	R		
688-702	Unload Hours <10,000 Alarm Hist.	R		
704-718	Status Alarm History	R		See FIGURE 10-3
999	IRI Version Number	R		Reads from IRI only

FIGURE 10-1 REGISTER 40001 STATUS / CONTROL

<p>Bit 0: Host/Local (R/W) 0 = Local 1 = Host</p> <p>Bit 1: Run/Stop (R/W) 0 = Stop 1 = Run</p> <p>Bit 2: Load/Unload (R/W) 0 = Unload 1 = Load</p> <p>Bit 3-4: Load Level (R/W) 00 = 25% 01 = 50% 10 = 75% 11 = 100%</p> <p>Bit 5: Stopped in Auto Restart (R) 0 = Not Stopped in Auto Restart 1 = Stopped in Auto Restart</p>	<p>Bit 6: Alarm (R) 0 = No Alarms 1 = Alarms</p> <p>Bit 7: Warning (R) 0 = No Warnings 1 = Warnings</p> <p>Bit 8: Constant Speed Mode (R) 0 = Not in Const. Speed Mode 1 = Constant Speed Mode</p> <p>Bit 9: Auto/Dual Mode (R) 0 = Not in Auto/Dual Mode 1 = Auto/Dual Mode</p> <p>Bits 10-12: Unused</p> <p>Bits 13-15: Unit Type (R) 111 = Recip controller</p>
--	---

FIGURE 10-2 REGISTER CODES

<p>Register 097: Recip Type 1 = LLE 2 = XLE 3 = PHE</p> <p>Register 099: Language Register 0 = English 1 = Other language</p>	<p>Register 098: Regulation Type 0 = 2 step 1 = 3 step 2 = 5 step (4 output) 3 = 5 step (3 output)</p> <p>Register 100: Units of Measure 0 = °F and PSI 1 = °C and PSI 2 = °C and Bar 3 = °C and kPa 4 = °C and kg/cm2</p>
--	---

FIGURE 10-3 REGISTER STATUS ALARM HISTORY

<p>Bit 0: Run/Stop (R) 0 = Stop 1 = Run</p> <p>Bit 1: Constant Speed Mode (R) 0 = Not in Constant Speed Mode 1 = Constant Speed Mode</p> <p>Bit 2: Auto Dual Mode (R) 0 = Not in Auto Dual Mode 1 = Auto Dual Mode</p> <p>Bit 3: Load/Unload (R) 0 = Unload 1 = Load</p>	<p>Bit 4: Stopped Auto Restart (R) 0 = Not Stopped in Auto Restart 1 = Stopped in Auto Restart</p> <p>Bits 5-6: Load Level 00 = 25% Load 01 = 50% Load 10 = 75% Load 11 = 100% Load</p> <p>Bit 7: Unused</p>
--	---

FIGURE 10-4 REGISTER ALARM / WARNING CODES

RECIP BOOSTER (REDEYE) CONTROLLER	
Code	Description
01	1st Stage Disch. Press. Sensor Failure
02	Package Disch. Press. Sensor Failure
03	Package Suction Sensor Failure
04	Frame Oil Press. Sensor Failure
05	Pkg. Water In Press. Sensor Failure
06	Pkg. Water Out Press. Sensor Failure
07	Pressure AA Sensor Failure
08	Pressure BB Sensor Failure
17	1st Stage Disch. Temp. Sensor Failure
18	2nd Stage Disch. Temp. Sensor Failure
19	Frame Oil Temp. Sensor Failure
20	Pkg. Water In Temp. Sensor Failure
21	2nd Stage Air In Temp. Sensor Failure
22	Package Inlet Air Temp. Sensor Failure
23	Package Wtr Out Temp. Sensor Failure
33	Emergency Stop
34	Starter Fault
35	Main Motor Overload
36	Motor Not Synchronized
37	Lubricator Failure
38	Intercooler Condensate
39	Aftercooler Condensate
40	Lubricator Oil
41	Frame Oil
42	Switch AA
43	Switch BB
44	Remote Stop Failure
45	Remote Start Failure
46	1st Stage Discharge Temp.
47	2nd Stage Discharge Temp.
48	Frame Oil Temp.
49	Package Water In Temp. (Low)
50	Package Water In Temp. (High)
51	2nd Stage Air In Temp.
58	Low 1st Stage Discharge Pressure
59	High 1st Stage Discharge Pressure
60	Low Package Discharge Pressure
61	Package Discharge Pressure
62	Air Filter Pressure Drop
63	Frame Oil Pressure
64	Package Water In Pressure (Low)
65	Package Water In Pressure (High)
66	Package Water Pressure Loss
67	Pressure AA
68	Pressure BB
77	High Disch. Press. caused by host

TABLE 11 NIRVANA (SGN) CC (CONTACT COOLED) CONTROLLER

Register (40XXX)	Variable	Read/Write	Range	Notes
1	Status/Control	R/W		See FIGURE 11-1
3	Discharge Pressure	R		
4	Sump Pressure	R		
5	Dry Side Sump Pressure	R		
6	Spare Pressure Input 4	R		
7	Spare Pressure Input 5	R		
8	Spare Pressure Input 6	R		
9	Spare Pressure Input 7	R		
10	Spare Pressure Input 8	R		
11	Coolant Temperature	R		
12	Airend Temperature	R		
13	Discharge Temperature	R		
14	Spare Temperature Input 4	R		
15	Spare Temperature Input 5	R		
16	Spare Temperature Input 6	R		
17	Spare Temperature Input 7	R		
18	Spare Temperature Input 8	R		
19	Separator Pressure Drop	R		
20	Percent Capacity	R		
21	Percent Energy Savings	R		
25	Motor Speed	R		
26	Motor Current	R		
27	Input Voltage	R		VAC
28	DC Bus Voltage	R		
29	Remote Pressure	R		
30	Motor Voltage	R		
31	Package kW	R		
32	kW Hours	R	0 – 999	Add to (mW hours * 1000)
33	mW Hours	R		
48	Average Package kW-hr	R		
49	Average % Capacity	R		
50	Average Capacity	R		CFM or M3
51	Package Energy Cost (Low)	R	0 – 99.99	Divide by 100
52	Package Energy Cost (High)	R		Multiply by 100
53	Energy Savings (Low)	R	0 – 99.99	Divide by 100
54	Energy Savings (High)	R		Multiply by 100
55	Lifetime Energy Saving (Low)	R	0 – 99.99	Divide by 100
56	Lifetime Energy Saving (High)	R		Multiply by 100
64	Total Hours (hours)	R	0 – 9999	Less Than 10000
65	Ten Thousand Total Hours	R		Multiply by 10000
96	Language Selection	R	0 – 11	See FIGURE 11-2
97	Units of Measure	R	0 – 4	See FIGURE 11-2
98	Kilowatt Rating	R	0 – 12	See FIGURE 11-2
99	Service Level	R	0 or 1	0=Level 1, 1=Level 2
100	Service Type	R	0 or 1	0=Hours, 1=Months
101	Service Interval	R	0 - 3	3, 6, 9, or 12 months
112	Target Pressure	R/W	65 - 145	
113	Auto Stop Pressure	R/W	(T+1)-(T+10)	T = target pressure
114	Immediate Stop Pressure	R/W	ASP-(ASP+10)	ASP = auto stop pressure
115	Blowdown Mode	R/W	0 or 1	0=Off, 1=On
116	Energy Rate	R		Divide by 1000
117	Compare Savings To	R/W	0 - 2	0=Mod, 1=On/Off, 2= Geo
120	Remote Sensor	R	0 or 1	0=Off, 1=On
121	Sequence Control On/Off	R	0 or 1	0=Off, 1=On
122	Remote Start/Stop On/Off	R	0 or 1	0=Off, 1=On
123	Power Out Restart Option (PORO)On/Off	R	0 or 1	0=Off, 1=On

124	PORO Time (seconds)	R/W	10 - 600	No Write if PORO is off
125	Low Ambient Option On/Off	R	0 or 1	0=Off, 1=On
126	Min. Cooler Out Load Temp	R/W	30 - 150	Low Ambient Option
127	Scheduled Start - Day	R/W	0 - 9	
128	Scheduled Stop - Day	R/W	0 - 9	
129	Scheduled Start (Hour)	R/W	0 - 23	
130	Scheduled Start (Minute)	R/W	0 - 59	
131	Scheduled Stop (Hour)	R/W	0 - 23	
132	Scheduled Stop (Minute)	R/W	0 - 59	
133	Modbus Protocol	R	0 or 1	0=Off, 1=On
134	Modbus Address	R	1 - 247	
250	Options	R		See FIGURE 11-2
251	VSD Software Version Number	R		Divide by 10
252	Software Part Number – Most Significant	R		High Digits
253	Software Part Number – Least Significant	R		Low Digits
254	Software Version Number	R		Divide by 100
255	Warning Code	R		See FIGURE 11-4
256-270	Alarm Code History	R		See FIGURE 11-4
272-286	Discharge Pressure Alarm History	R		
288-302	Sump Pressure Alarm History	R		
304-318	Dry Side Sump Pressure Alarm History	R		
320-334	Remote Pressure Sensor Alarm History	R		
336-350	Coolant Temperature Alarm History	R		
352-366	Airend Temperature Alarm History	R		
368-382	Discharge Temperature Alarm History	R		
384-398	Total Hours Alarm History	R		Less Than 10000 Hours
400-414	10000 Total Hours Alarm History	R		Multiply by 10000
416-430	Percent Capacity Alarm History	R		
448-462	Package kW alarm History	R		
464-478	Motor Voltage Alarm History	R		
480-494	Motor Speed Alarm History	R		
496-510	Motor Current Alarm History	R		
512-526	Input Voltage Alarm History	R		
528-542	DC Bus Voltage Alarm History	R		
544-558	Status Alarm History	R		See FIGURE 11-3
560-574	Real Time Clock Alarm History – Hours	R		
576-590	Real Time Clock Alarm History – Minutes	R		
592-606	Real Time Clock Alarm History – Month	R		
608-622	Real Time Clock Alarm History – Date	R		
624-638	Real Time Clock Alarm History – Year	R		
640-654	IGBT U Temperature Alarm History	R		Modular Drive Only
656-670	IGBT V Temperature Alarm History	R		Modular Drive Only
672-686	IGBT W Temperature Alarm History	R		Modular Drive Only
688-702	Input Rectifier Temperature Alarm History	R		Modular Drive Only
704-718	VSD Ambient Temperature Alarm History	R		Modular Drive Only
999	IRI Version Number	R		Reads from IRI only

FIGURE 11-1 REGISTER 40001 STATUS / CONTROL

<p>Bit 0: Host/Local (R/W) 0 = Local 1 = Host</p> <p>Bit 1: Run/Stop (R/W) 0 = Stop 1 = Run</p> <p>Bit 2: Load/Unload (R/W) 0 = No Load 1 = Load</p> <p>Bit 3: Operating at Minimum Speed (R) 0 = Operating above Minimum Speed 1 = Operating at Minimum Speed</p> <p>Bit 4: Operating at Maximum Speed (R) 0 = Operating below Maximum Speed 1 = Operating at Maximum Speed</p> <p>Bit 5: Stopped in Auto Restart (R) 0 = Not Stopped in Auto Restart 1 = Stopped in Auto Restart</p>	<p>Bit 6: Alarm (R) 0 = No Alarms 1 = Alarms</p> <p>Bit 7: Warning (R) 0 = No Warnings 1 = Warnings</p> <p>Bits 8 - 9: Normal/Unloaded 00 = Unloaded Operation 11 = Normal Operation</p> <p>Bit 12: Nirvana Compressor (R) 0 = Not Nirvana 1 = Nirvana</p> <p>Bit 13-15: Unit Type (R) 001 SSR controller</p>
--	---

FIGURE 11-2 REGISTER CODES

<p>Register 096: Language 0 = English 1 = Spanish 2 = Portuguese 3 = French 4 = Italian 5 = Dutch</p> <p>6 = German 7 = Danish 8 = Norwegian 9 = Swedish 10 = Finnish 11 = Turkish</p> <p>Register 98: Compressor Type 0 = 37kW / 50HP 1 = 45kW / 60HP 2 = 55kW / 75HP 3 = 75kW / 100HP</p> <p>Register 250: Options Bit 0: Power Out Restart and Scheduled Start/Stop 0 = Off 1 = On Bit 1: Remote Start/Stop 0 = Off 1 = On</p>	<p>Register 097: Units of Measure 0 = °F and PSI 1 = °C and PSI 2 = °C and Bar 3 = °C and kPa 4 = °C and kg/cm2</p> <p>Register 127: Schedule Start - Day Register 128: Schedule Stop - Day 0 = Sunday 1 = Monday 2 = Tuesday 3 = Wednesday 4 = Thursday 5 = Friday 6 = Saturday 7 = Daily 8 = Weekdays 9 = Weekends</p>
---	---

FIGURE 11-3 REGISTER STATUS ALARM HISTORY

<p>Bit 0: Run/Stop (R) 0 = Stop 1 = Run</p> <p>Bits 1-3: Unused</p>	<p>Bit 4: Stopped Auto Restart (R) 0 = Not Stopped in Auto Restart 1 = Stopped in Auto Restart</p> <p>Bits 5-7: Unused</p>
---	--

FIGURE 11-4 REGISTER ALARM / WARNING CODES

NIRVANA (SGN) CC (CONTACT COOLED) CONTROLLER	
Code	Description
01	Sensor Failure 4APT
02	Sensor Failure 3APT
03	Sensor Failure 6APT
04	Sensor Failure P4 (Spare)
05	Sensor Failure P5 (Spare)
06	Sensor Failure P6 (Spare)
07	Sensor Failure P7 (Spare)
08	Sensor Failure P8 (Spare)
09	Sensor Failure 2CTT
10	Sensor Failure 2ATT
11	Sensor Failure 4ATT
12	Sensor Failure T4 (Spare)
13	Sensor Failure T5 (Spare)
14	Sensor Failure T6 (Spare)
15	Sensor Failure T7 (Spare)
16	Sensor Failure T8 (Spare)
17	Sensor Failure Remote (Optional)
18	High VSD Temperature
19	Fan Motor Overload
20	VSD Communication Failure
21	VSD Initialization Fault
22	Check Motor Rotation
23	Stop Failure
24	Control Power Loss
25	Remote Stop Failure
26	Remote Start Failure
27	Incorrect VSD Type
28	Replace Coolant Filter (Idle Mode)
29	High Air Pressure
30	Low Sump Air Pressure
31	High A/E Discharge Temperature
32	Emergency Stop
33	Change Inlet Filter
34	Change Separator Element
35	Change Coolant Filter
36	Invalid Calibration
37	Check Set Points
38	100 Hours/14 Days To Service
39	Service Required
40	Alarm - Service Required
41	Auxiliary 2
42	Auxiliary 1
43	High Start Pressure
NIRVANA (SGN) CC (CONTACT COOLED) CONTROLLER	

Code	Description
100	VSD Fault 0
101	VSD Fault 1
102	VSD Fault 2
103	VSD Fault 3
104	VSD Fault 4
105	VSD Fault 5
106	VSD Fault 6
107	VSD Fault 7
108	VSD Fault 8
109	VSD Fault 9
110	VSD Fault 10
111	VSD Fault 11
112	VSD Fault 12
113	VSD Fault 13
114	VSD Fault 14
115	VSD Fault 15
116	VSD Fault 16
117	VSD Fault 17
118	VSD Fault 18
119	VSD Fault 19
120	VSD Fault 20
121	VSD Fault 21
122	VSD Fault 22
123	VSD Fault 23
124	VSD Fault 24
125	VSD Fault 25
126	VSD Fault 26
127	VSD Fault 27
128	VSD Fault 28
129	VSD Fault 29
130	VSD Fault 30
131	VSD Fault 31
133	VSD Fault 33
134	VSD Fault 34
135	VSD Fault 35
136	VSD Fault 36
137	VSD Fault 37
138	VSD Fault 38
139	VSD Fault 39
140	VSD Fault 40
141	VSD Fault 41
142	VSD Fault 42
143	VSD Fault 43
144	VSD Fault 44

TABLE 12 NIRVANA (SGNe) CC (CONTACT COOLED) CONTROLLER

Register (40XXX)	Variable	Read/Write	Range	Notes
1	Status/Control	R/W		See FIGURE 12-1
3	Discharge Pressure	R		
4	Sump Pressure	R		
5	Dry Side Sump Pressure	R		
6	Interstage Pressure	R		Only in 2-stage units.
7	Spare Pressure Input 5	R		
8	Spare Pressure Input 6	R		
9	Spare Pressure Input 7	R		
10	Spare Pressure Input 8	R		
11	Coolant Temperature	R		
12	Airend Temperature	R		
13	Discharge Temperature	R		
14	Inlet Temperature	R		
15	Cooler Out Temperature	R		Units with Hot Side Thermal Valve Only
16	Spare Temperature Input 6	R		
17	Spare Temperature Input 7	R		
18	Spare Temperature Input 8	R		
19	Separator Pressure Drop	R		
20	Percent Capacity	R		
21	Percent Energy Savings	R		
25	Motor Speed	R		
26	Motor Current	R		
27	Input Voltage	R		VAC
28	DC Bus Voltage	R		
29	Remote Pressure	R		
30	Motor Voltage	R		
31	Package kW	R		
32	kW Hours	R	0 – 999	Add to (mW hours * 1000)
33	mW Hours	R		
48	Average Package kW-hr	R		
49	Average % Capacity	R		
50	Average Capacity	R		CFM or M3
51	Package Energy Cost (Low)	R	0 – 99.99	Divide by 100
52	Package Energy Cost (High)	R		Multiply by 100
53	Energy Savings (Low)	R	0 – 99.99	Divide by 100
54	Energy Savings (High)	R		Multiply by 100
55	Lifetime Energy Saving (Low)	R	0 – 99.99	Divide by 100
56	Lifetime Energy Saving (High)	R		Multiply by 100
64	Total Hours (hours)	R	0 – 9999	Less Than 10000
65	Ten Thousand Total Hours	R		Multiply by 10000
96	Language Selection	R	0 – 20	See FIGURE 12-2
97	Units of Measure	R	0 – 4	See FIGURE 12-2
98	Kilowatt Rating	R	0 – 29	See FIGURE 12-2
99	Service Level	R	0 or 1	0=Level 1, 1=Level 2
100	Service Type	R	0 or 1	0=Hours, 1=Months
101	Service Interval	R	0 - 3	3, 6, 9, or 12 months
102	Water Cooled	R	0 or 1	0=Off, 1=On
103	Hot Side Thermal Valve	R	0 or 1	0=Off, 1=On
112	Target Pressure	R/W	65 - 145	
113	Auto Stop Pressure	R/W	(T+1)-(T+10)	T = target pressure
114	Immediate Stop Pressure	R/W	ASP-(ASP+10)	ASP = auto stop pressure
115	Blowdown Mode	R/W	0 or 1	0=Off, 1=On
116	Energy Rate	R		Divide by 1000
117	Compare Savings To	R/W	0 - 2	0=Mod, 1=On/Off, 2= Geo
118	Condensate Release Time	R	2-20	

119	Condensate Interval Time	R	90 - 270	
120	Remote Sensor	R	0 or 1	0=Off, 1=On
121	Sequence Control On/Off	R	0 or 1	0=Off, 1=On
122	Remote Start/Stop On/Off	R	0 or 1	0=Off, 1=On
123	Power Out Restart Option (PORO)On/Off	R	0 or 1	0=Off, 1=On
124	PORO Time (seconds)	R/W	10 - 600	No Write if PORO is off
127	Scheduled Start - Day	R/W	0 - 9	
128	Scheduled Stop - Day	R/W	0 - 9	
129	Scheduled Start (Hour)	R/W	0 - 23	
130	Scheduled Start (Minute)	R/W	0 - 59	
131	Scheduled Stop (Hour)	R/W	0 - 23	
132	Scheduled Stop (Minute)	R/W	0 - 59	
133	Modbus Protocol	R	0 or 1	0=Off, 1=On
134	Modbus Address	R	1 - 247	
135	Reset Averaging	R/W	01010 - 12319	MMDDY
250	Options	R		See FIGURE 12-2
251	VSD Software Version Number	R		Divide by 10
252	Software Part Number – Most Significant	R		High Digits
253	Software Part Number – Least Significant	R		Low Digits
254	Software Version Number	R		Divide by 100
255	Warning Code	R		See FIGURE 12-4
256-270	Alarm Code History	R		See FIGURE 12-4
272-286	Discharge Pressure Alarm History	R		
288-302	Sump Pressure Alarm History	R		
304-318	Dry Side Sump Pressure Alarm History	R		
320-334	Remote Pressure Sensor Alarm History	R		
336-350	Coolant Temperature Alarm History	R		
352-366	Airend Temperature Alarm History	R		
368-382	Discharge Temperature Alarm History	R		
384-398	Total Hours Alarm History	R		Less Than 10000 Hours
400-414	10000 Total Hours Alarm History	R		Multiply by 10000
416-430	Percent Capacity Alarm History	R		
432-446	Inlet Temperature Alarm History	R		
448-462	Package kW alarm History	R		
464-478	Motor Voltage Alarm History	R		
480-494	Motor Speed Alarm History	R		
496-510	Motor Current Alarm History	R		
512-526	Input Voltage Alarm History	R		
528-542	DC Bus Voltage Alarm History	R		
544-558	Status Alarm History	R		See FIGURE 12-3
560-574	Real Time Clock Alarm History – Hours	R		
576-590	Real Time Clock Alarm History – Minutes	R		
592-606	Real Time Clock Alarm History – Month	R		
608-622	Real Time Clock Alarm History – Date	R		
624-638	Real Time Clock Alarm History – Year	R		
640-654	Interstage Pressure Alarm History	R		Only in 2-stage units.
656-670	IGBT U Temperature Alarm History	R		
672-686	IGBT V Temperature Alarm History	R		
688-702	IGBT W Temperature Alarm History	R		
704-718	Input Rectifier Temperature Alarm History	R		
720-734	VSD Ambient Temperature Alarm History	R		
736-750	Cooler Out Temperature Alarm History	R		
999	IRI Version Number	R		Reads from IRI only

FIGURE 12-1 REGISTER 40001 STATUS / CONTROL

<p>Bit 0: Host/Local (R/W) 0 = Local 1 = Host</p> <p>Bit 1: Run/Stop (R/W) 0 = Stop 1 = Run</p> <p>Bit 2: Load/Unload (R/W) 0 = No Loaded Operation 1 = Loaded Operation</p> <p>Bit 3: Operating at Minimum Speed (R) 0 = Operating above Minimum Speed 1 = Operating at Minimum Speed</p> <p>Bit 4: Operating at Maximum Speed (R) 0 = Operating below Maximum Speed 1 = Operating at Maximum Speed</p> <p>Bit 5: Stopped in Auto Restart (R) 0 = Not Stopped in Auto Restart 1 = Stopped in Auto Restart</p>	<p>Bit 6: Alarm (R) 0 = No Alarms 1 = Alarms</p> <p>Bit 7: Warning (R) 0 = No Warnings 1 = Warnings</p> <p>Bits 8 - 9: Normal/Unload Operate (R) 00 = Unloaded Operation 11 = Normal Operation</p> <p>Bits 10 – 11: Unused</p> <p>Bit 12: Nirvana Compressor (R) 0 = Not Nirvana 1 = Nirvana</p> <p>Bits 13-15: Unit Type (R) 001 = SSR controller</p>
--	---

FIGURE 12-2 REGISTER CODES

<p>Register 096: Language 0 = English 1 = Spanish 2 = Portuguese 3 = French 4 = Italian 5 = Dutch 6 = German 7 = Danish 8 = Norwegian 9 = Swedish 10 = Finnish</p>	<p>11 = Turkish 12 = Lithuanian 13 = Latvian 14 = Estonian 15 = Maltese 16 = Slovenian 17 = Slovakian 18 = Czech 19 = Hungarian 20 = Polish</p>	<p>Register 097: Units of Measure 0 = °F and PSI 1 = °C and PSI 2 = °C and Bar 3 = °C and kPa 4 = °C and kg/cm2</p>
<p>Register 98: Compressor Type 0 = 37kW/50HP 1 = 45kW/60HP 2 = 55kW/75HP 3 = 75kW/100HP 4 = 90kW 5 = 125HP 6 = 110kW 7 = 150HP 8 = 132kW 9 = 200HP 10 = 160kW 11 = 75kW/100HP-2S 12 = 90kW-2S 13 = 125HP-2S 14 = 110kW-2S</p>	<p>15 = 150HP-2S 16 = 132kW-2S 17 = 200HP -2S 18 = 160kW-2S 19 = 250HP-2S 20 = 200kW-2S 21 = 300HP-2S 22 = 250kW-2S 23 = 90kW-2S XP 24 = 125HP-2S XP 25 = 110kW-2S XP 26 = 150HP-2S XP 27 = 132kW-2S XP 28 = 200HP-2S XP 29 = 160kW-2S XP</p>	<p>Register 127: Schedule Start - Day Register 128: Schedule Stop - Day 0 = Sunday 1 = Monday 2 = Tuesday 3 = Wednesday 4 = Thursday 5 = Friday 6 = Saturday 7 = Daily 8 = Weekdays 9 = Weekends</p>
<p>Register 250: Options Bit 0: Power Out Restart and Scheduled Start/Stop 0 = Off 1 = On</p> <p>Bit 1: Remote Start/Stop 0 = Off 1 = On</p>		

FIGURE 12-3 REGISTER STATUS ALARM HISTORY

Bit 0: Run/Stop (R) 0 = Stop 1 = Run Bits 1-3: Unused	Bit 4: Stopped Auto Restart (R) 0 = Not Stopped in Auto Restart 1 = Stopped in Auto Restart Bits 5-7: Unused
--	---

FIGURE 12-4 REGISTER ALARM / WARNING CODES

NIRVANA (SGNe) CC (CONTACT COOLED) CONTROLLER	
Code	Description
01	Sensor Failure 4APT
02	Sensor Failure 3APT
03	Sensor Failure 6APT
04	Sensor Failure 2APT (2-stage units)
05	Sensor Failure P5 (Spare)
06	Sensor Failure P6 (Spare)
07	Sensor Failure P7 (Spare)
08	Sensor Failure P8 (Spare)
09	Sensor Failure 2CTT
10	Sensor Failure 2ATT
11	Sensor Failure 4ATT
12	Sensor Failure 1ATT
13	Sensor Failure T5 (Spare)
14	Sensor Failure T6 (Spare)
15	Sensor Failure T7 (Spare)
16	Sensor Failure T8 (Spare)
17	Sensor Failure Remote (Optional)
18	High VSD Temperature
19	Blower Fault
20	VSD Communication Failure
21	VSD Initialization Fault
22	Check Motor Rotation
23	Stop Failure
24	Control Power Loss
25	Remote Stop Failure
26	Remote Start Failure
27	Incorrect VSD Type
28	Replace Coolant Filter (Idle Mode)
29	High Air Pressure
30	Low Sump Air Pressure
31	High A/E Discharge Temperature
32	Emergency Stop
33	Change Inlet Filter
34	Change Separator Element
35	Change Coolant Filter
36	Invalid Calibration
37	Check Set Points
38	100 Hours/14 Days To Service
39	Service Required
40	Alarm – Service Required
41	Auxiliary 2
42	Auxiliary 1
43	High Start Pressure
44	Condensate Drain Error
45	High Interstage Pressure

NIRVANA (SGNe) CC (CONTACT COOLED) CONTROLLER	
Code	Description
100	VSD Fault 0
101	VSD Fault 1
102	VSD Fault 2
103	VSD Fault 3
104	VSD Fault 4
105	VSD Fault 5
106	VSD Fault 6
107	VSD Fault 7
108	VSD Fault 8
109	VSD Fault 9
110	VSD Fault 10
111	VSD Fault 11
112	VSD Fault 12
113	VSD Fault 13
114	VSD Fault 14
115	VSD Fault 15
116	VSD Fault 16
117	VSD Fault 17
118	VSD Fault 18
119	VSD Fault 19
120	VSD Fault 20
121	VSD Fault 21
122	VSD Fault 22
123	VSD Fault 23
124	VSD Fault 24
125	VSD Fault 25
126	VSD Fault 26
127	VSD Fault 27
128	VSD Fault 28
129	VSD Fault 29
130	VSD Fault 30
131	VSD Fault 31
133	VSD Fault 33
134	VSD Fault 34
135	VSD Fault 35
136	VSD Fault 36
137	VSD Fault 37
138	VSD Fault 38
139	VSD Fault 39
140	VSD Fault 40
141	VSD Fault 41
142	VSD Fault 42
143	VSD Fault 43
144	VSD Fault 44

TABLE 13 NIRVANA SGN_e OF (OIL-FREE) CONTROLLER

Register (40XXX)	Variable	Read/W/rite	Range	Notes
1	Status/Control	R/W		See FIGURE 13-1
3	Discharge Pressure	R		
4	2nd Stage Inlet Pressure	R		
5	2nd Stage Discharge Pressure	R		
6	Inlet Vacuum	R		
7	Oil Filter Pressure Drop	R		
8	Bearing Oil Pressure	R		
9	2nd Stage Inlet Temperature	R		
10	1st Stage Discharge Temperature	R		
11	2nd Stage Discharge Temperature	R		
12	Bearing Oil Temperature	R		
13	Discharge Temperature	R		
14	Spare Pressure Input 7	R		
15	Spare Temperature Input 5	R		
16	Spare Temperature Input 6	R		
17	Spare Temperature Input 7	R		
18	Spare Temperature Input 8	R		
19	1st Stage Inlet Temperature	R		
20	Percent Capacity	R		
21	Percent Energy Savings	R		
22	Blower Speed	R		Percentage
25	Motor Speed	R		
26	Motor Current	R		
27	Input Voltage	R		VAC
28	DC Bus Voltage	R		
29	Remote Pressure	R		
30	Motor Voltage	R		Amps
31	Package kW	R		
32	kW Hours	R	0 – 999	Add to (mW hours * 1000)
33	mW Hours	R		
34	Motor kW	R		
48	Average Package kW-hr	R		
49	Average % Capacity	R		
50	Average Capacity	R		CFM or M3
51	Package Energy Cost (Low)	R	0 – 99.99	Divide by 100
52	Package Energy Cost (High)	R		Multiply by 100
53	Energy Savings (Low)	R	0 – 99.99	Divide by 100
54	Energy Savings (High)	R		Multiply by 100
55	Lifetime Energy Saving (Low)	R	0 – 99.99	Divide by 100
56	Lifetime Energy Saving (High)	R		Multiply by 100
64	Total Hours (hours)	R	0 – 9999	Less Than 10000
65	Ten Thousand Total Hours	R		Multiply by 10000
96	Language Selection	R	0 – 20	See FIGURE 13-2
97	Units of Measure	R	0 – 4	See FIGURE 13-2
98	Kilowatt Rating	R	0 – 14	See FIGURE 13-2
99	Service Level	R	0 or 1	0=Level 1, 1=Level 2
100	Service Type	R	0 or 1	0=Hours, 1=Months
101	Service Interval	R	0 - 3	3, 6, 9, or 12 months
112	Target Pressure	R/W	65 - 145	
113	Auto Stop Pressure	R/W	(T+1)-(T+10)	T = target pressure
114	Immediate Stop Pressure	R/W	ASP-(ASP+10)	ASP = auto stop pressure
116	Energy Rate	R		Divide by 1000
118	Condensate Interval Time	R	90 - 270	
119	Condensate Release Time	R	2-20	
120	Remote Sensor Enable	R	0 or 1	0=Off, 1=On
121	Sequence Control On/Off	R	0 or 1	0=Off, 1=On

122	Remote Start/Stop On/Off	R	0 or 1	0=Off, 1=On
123	Power Out Restart Option (PORO)On/Off	R	0 or 1	0=Off, 1=On
124	PORO Time (seconds)	R/W	10 - 600	No Write if PORO is off
125	Low Ambient On/Off	R	0 or 1	0=Off, 1=On
127	Scheduled Start - Day	R/W	0 - 9	
128	Scheduled Stop - Day	R/W	0 - 9	
129	Scheduled Start (Hour)	R/W	0 – 23	
130	Scheduled Start (Minute)	R/W	0 – 59	
131	Scheduled Stop (Hour)	R/W	0 – 23	
132	Scheduled Stop (Minute)	R/W	0 – 59	
133	Modbus Protocol	R	0 or 1	0=Off, 1=On
134	Modbus Address	R	1 – 247	
135	Max 1st Stage Temperature	R		
136	Max 2nd Stage Temperature	R		
250	Options	R		See FIGURE 13-2
252	Software Part Number – Most Significant	R		High Digits
253	Software Part Number – Least Significant	R		Low Digits
254	Software Version Number	R		Divide by 100
255	Warning Code	R		See FIGURE 13-4
256-270	Alarm Code History	R		See FIGURE 13-4
272-286	Discharge Pressure Alarm History	R		
288-302	Discharge Temperature Alarm History	R		
304-318	1st Stage Inlet Temperature Alarm History	R		
320-334	1st Stage Disch Temperature Alarm History	R		
336-350	2nd Stage Inlet Pressure Alarm History	R		
352-366	2nd Stage Inlet Temperature Alarm History	R		
368-382	2nd Stage Disch Pressure Alarm History	R		
384-398	2nd Stage Disch Temp Alarm History	R		
400-414	Oil Pressure Alarm History	R		
416-430	Oil Temperature Alarm History	R		
432-446	Inlet Vacuum Alarm History	R		
448-462	Unused	R		
464-478	Oil Filter Alarm History	R		
480-494	Total Hours Alarm History	R		Less Than 10000 Hours
496-510	10000 Total Hours Alarm History	R		Multiply by 10000
512-526	Percent Capacity Alarm History	R		
528-542	Motor Speed Alarm History	R		
544-558	Motor Current Alarm History	R		
560-574	Input Voltage Alarm History	R		
576-590	DC Bus Voltage Alarm History	R		
592-606	Blower Speed Alarm History	R		Percentage
608-622	Package kW Alarm History	R		
624-638	Motor Voltage Alarm History	R		
640-654	Status Alarm History	R		See FIGURE 13-3
656-670	Real Time Clock Alarm History – Hours	R		
672-686	Real Time Clock Alarm History – Minutes	R		
688-702	Real Time Clock Alarm History – Month	R		
704-718	Real Time Clock Alarm History – Date	R		
720-734	Real Time Clock Alarm History – Year	R		
999	IRI Version Number	R		Reads from IRI only

FIGURE 13-1 REGISTER 40001 STATUS / CONTROL

<p>Bit 0: Host/Local (R/W) 0 = Local 1 = Host</p> <p>Bit 1: Run/Stop (R/W) 0 = Stop 1 = Run</p> <p>Bit 2: Load/Unload (R/W) 0 = No Loaded Operation 1 = Loaded Operation</p> <p>Bit 3: Operating at Minimum Speed (R) 0 = Operating above Minimum Speed 1 = Operating at Minimum Speed</p> <p>Bit 4: Operating at Maximum Speed (R) 0 = Operating below Maximum Speed 1 = Operating at Maximum Speed</p> <p>Bit 5: Stopped in Auto Restart (R) 0 = Not Stopped in Auto Restart 1 = Stopped in Auto Restart</p>	<p>Bit 6: Alarm (R) 0 = No Alarms 1 = Alarms</p> <p>Bit 7: Warning (R) 0 = No Warnings 1 = Warnings</p> <p>Bits 8 - 9: Normal/Unload Operate (R) 00 = Unloaded Operation 11 = Normal Operation</p> <p>Bits 10 - 11: Unused</p> <p>Bit 12: Nirvana Compressor (R) 0 = Not Nirvana 1 = Nirvana</p> <p>Bits 13-15: Unit Type (R) 100 = Sierra controller</p>
--	--

FIGURE 13-2 REGISTER CODES

<p>Register 096: Language 0 = English 1 = Spanish 2 = Portuguese 3 = French 4 = Italian 5 = Dutch 6 = German 7 = Danish 8 = Norwegian 9 = Swedish 10 = Finnish</p>	<p>11 = Turkish 12 = Lithuanian 13 = Latvian 14 = Estonian 15 = Maltese 16 = Slovenian 17 = Slovakian 18 = Czech 19 = Hungarian 20 = Polish</p>	<p>Register 097: Units of Measure 0 = °F and PSI 1 = °C and PSI 2 = °C and Bar 3 = °C and kPa 4 = °C and kg/cm2</p>
<p>Register 98: Compressor Type 0 = 22kW/30HP 1 = 30kW/40HP 2 = 37kW/50HP 3 = 45kW/60HP 4 = 55kW/75HP AC 5 = 55kW/75HP WC 6 = 75kW/100HP AC 7 = 75kW/100HP WC</p>	<p>8 = 90kW 9 = 125HP 10 = 110kW 11 = 150HP 12 = 132kW 13 = 200HP 14 = 160kW</p>	<p>Register 127: Schedule Start - Day Register 128: Schedule Stop - Day 0 = Sunday 1 = Monday 2 = Tuesday 3 = Wednesday 4 = Thursday 5 = Friday 6 = Saturday 7 = Daily 8 = Weekdays 9 = Weekends</p>
<p>Register 250: Options Bit 0: Power Out Restart and Scheduled Start/Stop 0 = Off 1 = On</p> <p>Bit 1: Remote Start/Stop 0 = Off 1 = On</p>		

FIGURE 13-3 REGISTER STATUS ALARM HISTORY

<p>Bit 0: Run/Stop (R) 0 = Stop 1 = Run</p>	<p>Bit 4: Stopped Auto Restart (R) 0 = Not Stopped in Auto Restart 1 = Stopped in Auto Restart</p>
--	---

FIGURE 13-4 REGISTER ALARM / WARNING CODES

NIRVANA SGNe OF (OIL-FREE) CONTROLLER	
Code	Description
1	Sensor Failure 1AVPT
2	Sensor Failure 2APT
3	Sensor Failure 3APT
4	Sensor Failure 4APT
5	Sensor Failure P5 (Spare)
6	Sensor Failure 5OPT
7	Sensor Failure 6OPT
8	Sensor Failure 1ATT
9	Sensor Failure 2ATT
10	Sensor Failure 3ATT
11	Sensor Failure 4ATT
12	Sensor Failure 5OTT
13	Sensor Failure 7ATT
14	Sensor Failure T6 (Spare)
15	Sensor Failure T7 (Spare)
16	Sensor Failure T8 (Spare)
17	Sensor Failure Remote (Optional)
18	High VSD Temperature
19	Fan Motor Overload
20	High 1ST Stage Discharge Temp
21	High 2nd Stage Discharge Temp
22	High Bearing Oil Temperature
23	High Intercooler Temperature
24	High 2nd Stage Over Ratio
25	Remote Stop Failure
26	Remote Start Failure
27	Incorrect VSD Type
28	High Intercooler Condensate Level
29	High Air Pressure
30	Low Bearing Oil Pressure
31	High 1st Stage Inlet Temperature
32	Emergency Stop
33	Inlet Restriction
34	High Intercooler Pressure
35	Oil Filter Pressure Drop
36	High 2nd Stage Discharge Pressure
37	Check Set Points
38	100 Hours/14 Days To Service
39	Service Required
40	Alarm - Service Required
41	Auxiliary 2
42	Auxiliary 1
43	Failed Check Valve
44	Condensate Drain Error
45	High Interstage Pressure
46	Control Power Loss
47	Invalid Calibration
50	VSD Communication Failure
51	VSD Initialization Fault
52	Stop Failure
53	Check Motor Rotation

NIRVANA SGNe OF (OIL-FREE) CONTROLLER	
Code	Description
100	VSD Fault 0
101	VSD Fault 1
102	VSD Fault 2
103	VSD Fault 3
104	VSD Fault 4
105	VSD Fault 5
106	VSD Fault 6
107	VSD Fault 7
108	VSD Fault 8
109	VSD Fault 9
110	VSD Fault 10
111	VSD Fault 11
112	VSD Fault 12
113	VSD Fault 13
114	VSD Fault 14
115	VSD Fault 15
116	VSD Fault 16
117	VSD Fault 17
118	VSD Fault 18
119	VSD Fault 19
120	VSD Fault 20
121	VSD Fault 21
122	VSD Fault 22
123	VSD Fault 23
124	VSD Fault 24
125	VSD Fault 25
126	VSD Fault 26
127	VSD Fault 27
128	VSD Fault 28
129	VSD Fault 29
130	VSD Fault 30
131	VSD Fault 31
133	VSD Fault 33
134	VSD Fault 34
135	VSD Fault 35
136	VSD Fault 36
137	VSD Fault 37
138	VSD Fault 38
139	VSD Fault 39
140	VSD Fault 40
141	VSD Fault 41
142	VSD Fault 42
143	VSD Fault 43
144	VSD Fault 44

TABLE 14 SSR UP (SE) CONTROLLER

Register (40XXX)	Variable	Read/Write	Range	Notes
1	Status/Control	R/W		See FIGURE 14-1
3	Discharge Pressure	R		
4	Sump Pressure	R		
5	Separator Pressure Drop	R		
6	Airend Temperature	R		
7	Spare Temperature	R		
64	Total Hours (hours)	R		
65	Loaded Hours (hours)	R		
96	Language Selection	R		See FIGURE 14-2
97	Units of Measure	R		See FIGURE 14-2
98	Rated Pressure	R		
99	High Temperature	R		
100	Starter Type	R		See FIGURE 14-2
101	Contrast	R		
102	Coolant Type	R		0 = Ultraplus, 1 = Ultracoolant
103	Dryer Installed	R	0 or 1	0 = No, 1 = Yes
112	Offline Pressure 1	R/W	75 - (rated+3)	
113	Online Pressure 1	R/W	65-(offline-10)	
114	Offline Pressure 2	R/W	75 - (rated+3)	
115	Online Pressure 2	R/W	65-(offline-10)	
116	Mode of Operation	R/W	0-2	See FIGURE 14-2
117	Star-Delta Timer (seconds)	R/W	4-15r	
118	Auto Start/Stop Time (minutes)	R/W	0, 2-60	0 = Off
119	Sequence Control On/Off	R	0 or 1	0=Off, 1=On
120	Remote Start/Stop On/Off	R	0 or 1	0=Off, 1=On
121	Power Out Restart Option(PORO) On/Off	R	0 or 1	0=Off, 1=On
122	PORO Time (seconds)	R/W	10-120	No Write if PORO is off
123	Auto Start Delay (seconds)	R/W	0 - 60	
124	Load Delay Time (seconds)	R/W	0 - 3600	
125	Contact Sequencing	R	0 or 1	0=Off, 1=On
255	Warning Code	R		See FIGURE 14-4
256-270	Alarm Code History	R		See FIGURE 14-4
272-286	Discharge Pressure Alarm History	R		
288-302	Sump Pressure Alarm History	R		
304-318	Airend Temperature Alarm History	R		
320-334	Spare Temperature Alarm History	R		
336-350	Separator Pressure Alarm History	R		
352-366	Run Hours Alarm History	R		
368-382	Load Hours Alarm History	R		
384-398	Status Alarm History	R		See FIGURE 14-3
999	IRI Version Number	R		Reads from IRI only

FIGURE 14-1 REGISTER 40001 STATUS / CONTROL

Bit 0: Host/Local (R/W) 0 = Local 1 = Host	Bit 6: Alarm 0 = No Alarms 1 = Alarms
Bit 1: Run/Stop (R/W) 0 = Stop 1 = Run	Bit 7: Warning (R) 0 = No Warnings 1 = Warnings
Bit 2: Load/Unload (R/W) 0 = Unload 1 = Load	Bit 8: On/Off Line Mode (R) 0 = Not in On/Off Line Mode 1 = On/Off Line Mode
Bit 3: Modulating (R) 0 = Not Modulating 1 = Load	Bit 9: Mod/ACS or Mod Only (R) 0 = Not in Mod/ASC or Mode 1 = Mod/ASC or Mod Mode
Bit 4: Sump Pressure (R/W) 1 = Get Sump Pressure	Bit 10-12: Unused
Bit 5: Stopped in Auto Restart (R) 0 = Not Stopped in Auto Restart 1 = Stopped in Auto Restart	Bit 13-15: Unit Type (R) 010 = SE controller

FIGURE 14-2 REGISTER CODES

Register 096: Language 0 = English 1 = Spanish 2 = French 3 = Portuguese 4 = Dutch 5 = Danish	6 = Italian 7 = Norwegian 8 = Swedish 9 = Finnish 10 = German 11 = Turkish	Register 098: Units of Measure 0 = °F and PSI 1 = °C and PSI 2 = °C and Bar 3 = °C and kPa 4 = °C and kg/cm2
Register 101: Starter Type 0 = Full Voltage 1 = Star-Delta 2 = No Starter	Register 116: Mode of Operation 0 = MOD/ACS 1 = Modulation Only 2 = On/Off Line	

FIGURE 14-3 REGISTER STATUS ALARM HISTORY

Bit 0: Run/Stop (R) 0 = Stop 1 = Run	Bit 4: Stopped Auto Restart (R) 0 = Not Stopped in Auto Restart 1 = Stopped in Auto Restart
Bit 1: On/Off Line Mode (R) 0 = Not in On/Off Line Mode 1 = On/Off Line Mode	Bit 5: Unused
Bit 2: MOD/ACS Mode (R) 0 = Not Modulating 1 = Modulating	Bit 6: Unused
Bit 3: Load/Unload (R) 0 = Unload 1 = Load	Bit 7: Unused

FIGURE 14-4 REGISTER ALARM / WARNING CODES

SSR UP (SE) CONTROLLER	
Code	Description
01	Pressure Sensor Failure
02	Temperature Sensor Failure
04	Starter Fault
05	Motor Overload
06	Reverse Rotation
07	Remote Stop Failure
08	Remote Start Failure
09	Calibration Error
10	High Airend Discharge Temperature
12	High Pressure
15	Separator Element
16	Control Power Loss
18	Emergency Stop
19	Low Sump Pressure
20	Check Set Points
21	Service Required

TABLE 15 ESA (SE) 22 – 150 KW CONTROLLER

Register (40XXX)	Variable	Read/Write	Range	Notes
1	Status/Control	R/W		See FIGURE 15-1
3	Discharge Pressure	R		
4	Sump Pressure	R		
5	Separator Pressure Drop	R		
6	Airend Temperature	R		
7	Spare Temperature	R		
64	Total Hours (hours)	R		
65	Loaded Hours (hours)	R		
96	Language Selection	R		See FIGURE 15-2
97	Kilowatt Rating	R		0 = 22 – 50 kW, 1 = 55 – 150 kW
98	Units of Measure	R		See FIGURE 15-2
99	Rated Pressure	R		
100	High Temperature	R		
101	Starter Type	R		See FIGURE 15-2
102	Contrast	R		
112	Offline Pressure 1	R/W	75 - (rated+3)	
113	Online Pressure 1	R/W	65-(offline-10)	
114	Offline Pressure 2	R/W	75 - (rated+3)	
115	Online Pressure 2	R/W	65-(offline-10)	
116	Mode of Operation	R/W	0-2	See FIGURE 15-2
117	Star-Delta Timer (seconds)	R/W	4-15	
118	Auto Start/Stop Time (minutes)	R/W	0, 2-60	0 = Off
119	Sequence Control On/Off	R	0 or 1	0=Off, 1=On
120	Remote Start/Stop On/Off	R	0 or 1	0=Off, 1=On
121	Power Out Restart Option(PORO) On/Off	R	0 or 1	0=Off, 1=On
122	PORO Time (seconds)	R/W	10-120	No Write if PORO is off
123	Load Delay Time (seconds)	R/W	0-60	
255	Warning Code	R		See FIGURE 15-4
256-270	Alarm Code History	R		See FIGURE 15-4
272-286	Discharge Pressure Alarm History	R		
288-302	Sump Pressure Alarm History	R		
304-318	Airend Temperature Alarm History	R		
320-334	Spare Temperature Alarm History	R		
336-350	Separator Pressure Alarm History	R		
352-366	Run Hours Alarm History	R		
368-382	Load Hours Alarm History	R		
384-398	Status Alarm History	R		See FIGURE 15-3
999	IRI Version Number	R		Reads from IRI only

FIGURE 15-1 REGISTER 40001 STATUS / CONTROL

<p>Bit 0: Host/Local (R/W) 0 = Local 1 = Host</p> <p>Bit 1: Run/Stop (R/W) 0 = Stop 1 = Run</p> <p>Bit 2: Load/Unload (R/W) 0 = Unload 1 = Load</p> <p>Bit 3: Modulating (R) 0 = Not Modulating 1 = Load</p> <p>Bit 4: Sump Pressure (R/W) 1 = Get Sump Pressure</p> <p>Bit 5: Stopped in Auto Restart (R) 0 = Not Stopped in Auto Restart 1 = Stopped in Auto Restart</p>	<p>Bit 6: Alarm 0 = No Alarms 1 = Alarms</p> <p>Bit 7: Warning (R) 0 = No Warnings 1 = Warnings</p> <p>Bit 8: On/Off Line Mode (R) 0 = Not in On/Off Line Mode 1 = On/Off Line Mode</p> <p>Bit 9: Mod/ACS or Mod Only (R) 0 = Not in Mod/ASC or Mode 1 = Mod/ASC or Mod Mode</p> <p>Bit 10-12: Unused</p> <p>Bit 13-15: Unit Type (R) 010 = SE controller</p>
---	--

FIGURE 15-2 REGISTER CODES

<p>Register 096: Language 0 = English 1 = Spanish 2 = French 3 = Portuguese 4 = Dutch 5 = Danish</p> <p>Register 101: Starter Type 0 = Full Voltage 1 = Star-Delta 2 = No Starter</p>	<p>6 = Italian 7 = Norwegian 8 = Swedish 9 = Finnish 10 = German 11 = Turkish</p>	<p>Register 098: Units of Measure 0 = °F and PSI 1 = °C and PSI 2 = °C and Bar 3 = °C and kPa 4 = °C and kg/cm2</p> <p>Register 116: Mode of Operation 0 = MOD/ACS 1 = Modulation Only 2 = On/Off Line</p>
--	--	--

FIGURE 15-3 REGISTER STATUS ALARM HISTORY

<p>Bit 0: Run/Stop (R) 0 = Stop 1 = Run</p> <p>Bit 1: On/Off Line Mode (R) 0 = Not in On/Off Line Mode 1 = On/Off Line Mode</p> <p>Bit 2: MOD/ACS Mode (R) 0 = Not Modulating 1 = Modulating</p> <p>Bit 3: Load/Unload (R) 0 = Unload 1 = Load</p>	<p>Bit 4: Stopped Auto Restart (R) 0 = Not Stopped in Auto Restart 1 = Stopped in Auto Restart</p> <p>Bit 5: Unused</p> <p>Bit 6: Unused</p> <p>Bit 7: Unused</p>
--	---

FIGURE 15-4 REGISTER ALARM / WARNING CODES

ESA (SE) 22 – 150 KW CONTROLLER	
Code	Description
01	Pressure Sensor Failure
02	Temperature Sensor Failure 1
03	Temperature Sensor Failure 2
04	Starter Fault
05	Motor Overload
06	Reverse Rotation
07	Remote Stop Failure
08	Remote Start Failure
09	Calibration Error
10	High Airend Discharge Temperature
11	High Separator Temperature
12	High Pressure
13	Air Filter
14	Coolant Filter
15	Separator Element
16	Control Power Loss
18	Emergency Stop
19	Low Sump Pressure
20	Check Set Points
21	Service Required

TABLE 16 R-SERIES (S3) CONTROLLER

Register (40XXX)	Variable	Read/Write	Range	Notes
1	Status/Control	R/W		See FIGURE 16-1
3	Package Discharge Pressure	R		
4	Sump Pressure	R		
7	Airend Temperature	R		
10	Separator Pressure Drop	R		
64	Total Hours (Hours)	R		
65	Loaded Hours (Hours)	R		
66	Total Hours (10,000 Hours)	R		
67	Loaded Hours (10,000 Hours)	R		
97	Units of Measure	R		See FIGURE 16-2
100	Starter Type TBD	R		
112	Offline Pressure	R/W		
113	Online Pressure	R/W		
114	Mode of Operation	R/W		
115	Star -Delta Time	R		
116	Auto Start/Stop Time	R/W		
118	Sequence Control On/Off	R		
119	Remote Start/Stop On/Off	R		
121	Power Out Restart Option(PORO) On/Off	R	0 or 1	0=Off, 1=On
122	PORO Time (seconds)	R/W	10-120	No Write if PORO is off
125	Scheduled Start/Stop On/Off	R		
129	Scheduled Start (Hour)	R/W		
130	Scheduled Start (Minute)	R/W		
131	Scheduled Stop (Hour)	R/W		
132	Scheduled Stop (Minute)	R/W		
134	Modbus Address	R		
254	Software Version	R		
255	Warning Code	R		See FIGURE 16-4
256-270	Alarm Code History	R		See FIGURE 16-4

FIGURE 16-1 REGISTER 40001 STATUS / CONTROL

<p>Bit 0: Host/Local (R/W) 0 = Local 1 = Host</p> <p>Bit 1: Run/Stop (R/W) 0 = Stop 1 = Run</p> <p>Bit 2: Load/Unload (R/W) 0 = Unload 1 = Load</p> <p>Bit 3: Modulating (R) 0 = Not Modulating 1 = Modulating</p> <p>Bit 4: Unused</p> <p>Bit 5: Stopped in Auto Restart (R) 0 = Not Stopped in Auto Restart 1 = Stopped in Auto Restart</p>	<p>Bit 6: Alarm (R) 0 = No Alarms 1 = Alarms</p> <p>Bit 7: Warning (R) 0 = No Warnings 1 = Warnings</p> <p>Bit 8: On/Off Line Mode (R) 0 = Not in On/Off Line 1 = On/Off Line Mode</p> <p>Bit 9 – 12: Unused</p> <p>Bits 13-15: Unit Type (R) TBD = S1 IR Control</p>
---	---

FIGURE 16-2 REGISTER CODES

<p>Register 097: Units of Measure 0 = °F and PSI 1 = °C and PSI 2 = °C and Bar 3 = °C and kPa</p>
--

FIGURE 16-4 REGISTER ALARM / WARNING CODES

R-SERIES (S3) CONTROLLER	
Code	Description
01	Motor Reverse Rotation
02	Emergency Stop
03	Motor Overload
04	Low Ambient Temperature
05	High Sump Air Pressure
06	Low Sump Air Pressure
07	P1 Pressure Sensor Failure
08	P2 Pressure Sensor Failure
09	Temperature Sensor Failure
10	P1 Pressure Sensor Calibration Failure
11	P2 Pressure Sensor Calibration Failure
12	High Package Discharge Pressure
13	High A/E Discharge Temperature
14	Maintenance Due Soon
15	Maintenance Due Immediately
16	Change Oil Filter
17	Change Air Filter
18	Change Separator Element
19	Integral Sequencing Comm Failure
20	Motor Overtemp

TABLE 17 NIRVANA 15-30 KW (20-40 HP) DF CONTROLLER

Register (40XXX)	Variable	Read/Write	Range	Notes
001	Control/Status	R/W	-	See FIGURE 17-1
003	Dryer Discharge Pressure	R	2013	Pressure in selected units PSI = 0. KPa = 0. BAR = 0.0
004	Aftercooler Discharge Pressure	R	2012	Same as 003
020	Percent of Load	R	2072	0. %
025	Motor Speed	R	1617	0. RPM
026	Motor Current	R	1614	0.00 A
028	DC Bus Voltage	R	1630	0. V
030	Motor Voltage	R	1612	0.0 V
031	Package KW	R	1610	0.00 KW
032	KW Hours	R	1502	0. KW
033	MW Hours	R	1502	0. MW
053	Energy Savings (w/ dec)	R	2077	0.
054	Energy Savings (w/o dec)	R	2077	0.00
055	Lifetime Energy Savings (w/ dec)	R	2071	0.
056	Lifetime Energy Savings (w/o dec)	R	2071	0.00
060	Time to Service Percentage	R	2075	0. %
064	Total Hours (< 10000)	R	1501	Hours under the 10000 hour overflow limit
065	Total Hours (> 10000)	R	1501	Hours over the 10000 hour overflow limit
096	Language Selection	R	0001	See FIGURE 17-2
097	Units of Measure	R	0301	Current pressure unit selection 0 = PSI, 1 = KPa, 2 = BAR
116	Energy Rate	R	2011	0.000
112	Target Pressure	R/W	0303	Same as 003
113	Auto Stop Pressure	R/W	2001	Same as 003
116	Energy Rate	R	2011	0.000
121	VFD/Fixed Speed Mode	R/W	2026	Local mode control selection 0 = VFD 1 = Fixed
122	Remote Control Off/On	R	2010	Remote control enable 0 = Off 1 = On
123	PORO Off/On	R	2008	PORO enable 0 = Off 1 = On
124	PORO Time	R/W	2009	0. s
125	Scheduled Start/Stop Off/On	R	2002	Scheduled start/stop enable 0 = Off 1 = On
129	Scheduled Start Hour	R/W	2003	0. h
130	Scheduled Start Minute	R/W	2003	0. min
131	Scheduled Stop Hour	R/W	2004	0. h
132	Scheduled Stop Minute	R/W	2004	0. min
133	Modbus Protocol Off/On	R	0830	Modbus Protocol Enable 0 = Off 1 = On
134	Modbus Address	R	0831	
252	Part Number	R	-	Upper 16 bits
253	Part Number	R	-	Lower 16 bits
254	Software Version	R	1543	0.00
255	Last Generated Warning Code	R	-	See FIGURE 17-3
256	Last Generated Alarm Code	R	-	See FIGURE 17-3
257-271	Alarm History: Alarm Number	R	1530	See FIGURE 17-3
272-286	Alarm History: Month	R	2090	
287-301	Alarm History: Date	R	2090	
302-316	Alarm History: Year	R	2090	
317-331	Alarm History: Hour	R	2090	
332-346	Alarm History: Minute	R	2090	
347-361	Alarm History: Aftercooler Pressure	R	2091	Pressure in unit corresponding to units of measure register PSI = 0. KPa = 0. BAR = 0.0

362-376	Alarm History: Dryer Pressure	R	2092	Same as 272-286
377-391	Alarm History: Hour Meter	R	2093	Compressor run time since last service 0. hours
392-406	Alarm History: Control/Status Word	R	2094	See FIGURE 17-1
407-421	Alarm History: Percent of Load	R	2095	0. %
422-436	Alarm History: Total Power	R	2096	0.00 KW
437-451	Alarm History: Heatsink Temp.	R	2097	0. °C
452-466	Alarm History: Ambient Temp.	R	2098	0. °C
467-481	Alarm History: Motor Speed	R	2086	History of last graph point 0. RPM
482-496	Alarm History: Motor Voltage	R	2087	History of last graph point 0.0 V
497-511	Alarm History: Motor Current	R	2088	History of last graph point 0.0 A
512-526	Alarm History: DC Bus Voltage	R	2089	History of last graph point 0. V
527-541	Alarm History: Units of Measure	R	2099	Pressure unit at time of alarm 0 = PSI 1 = KPa 2 = BAR

FIGURE 17-1 REGISTER 40001 STATUS / CONTROL

Bit Number	Variable	Read/Write	Description
0	Local/Host Mode	R/W	Read: 0 = Host mode disabled 1 = Drive in serial host mode Write: 0 = Disable serial control 1 = Enable serial host control
1	Stop/Run	R/W	Read: 0 = Stop has been generated 1 = Start has been generated Write: (host mode required) 0 = Generate serial stop command 1 = Generate serial start command
2	Unload/Load	R/W	Read: 0 = Drive currently unloaded (Stopped in Auto Restart) 1 = Drive currently loaded (Normal run control) Write: (host mode required) 0 = Unload the drive 1 = Load the drive
3	Operating at Minimum Speed	R	0 = Drive not running at min speed 1 = Drive running at min speed
4	Operating at Maximum Speed	R	0 = Drive not running at max speed 1 = Drive running at max speed
5	Stopped in Auto Restart	R	0 = Stopped in Auto Restart mode not active 1 = Stopped in Auto Restart mode active
6	Alarm Active	R	0 = No alarms currently active 1 = At least one alarm is currently active
7	Warning Active	R	0 = No warnings currently active 1 = At least one warning is currently active
8	Fixed Speed/VFD Control Mode	R/W	Read: 0 = Running in fixed speed mode 1 = Running in VFD control mode Write: (host mode required) 0 = Run in fixed speed mode 1 = Run in VFD control mode
9	NA	-	Read as 0
10	NA	-	Read as 0
11	NA	-	Read as 0
12	Unit Type Bit 0	R	Read as 1 (Nirvana Drive Type)
13	Unit Type Bit 1	R	Read as 0 (Nirvana Drive Type)
14	Unit Type Bit 2	R	Read as 1 (Nirvana Drive Type)
15	Unit Type Bit 2	R	Read as 0 (Nirvana Drive Type)

FIGURE 17-2 REGISTER CODES

Register 096: Language	
0=English	12=Turkish
1=Chinese	13=Lithuanian
2=Spanish	14=Latvian
3=Portuguese	15=Estonian
4=French	16=Maltese
5=Italian	17=Slovenian
6=German	18=Slovakian
7=Dutch	19=Czech
8=Danish	20=Hungarian
9=Norwegian	21=Polish
10=Swedish	22=Greek
11=Finnish	

FIGURE 17-3 REGISTER ALARM / WARNING CODES

NIRVANA 15-30 KW (20-40 HP) DF CONTROLLER	
Code	Description
02	Sensor Failure 2APT
03	Sensor Failure 3APT
04	Sensor Failure 4APT
05	Sensor Failure 5OPT (Warn)
06	Sensor Failure 6OPT
07	Sensor Failure P7 (Spare)
08	Sensor Failure P8 (Spare)
10	Sensor Failure 3ATT (Warn)
11	Sensor Failure 4ATT
12	Sensor Failure 5OTT
13	Sensor Failure 7ATT (Warn)
14	Sensor Failure T6 (Spare)
15	Sensor Failure T7 (Spare)
16	Sensor Failure T8 (Spare)
17	Starter Fault
18	Motor Overload (Main)
19	Fan Motor Overload
21	High Airend Discharge Temp.
22	High Bearing Oil Temp.
23	Hi I/C Air Temp.
24	Control Power Loss
25	Remote Stop Failure
26	Remote Start Failure
29	High Discharge Air Pressure
30	Low Bearing Oil Pressure
31	High I/C Pressure (Loaded)
32	Emergency Stop
33	Change Inlet Filter
34	High I/C Pressure (Unloaded)
35	Change Oil Filter (Warn)
36	Airend Stage Pressure
37	Memory Fault
38	Low Water Flow
39	High Condensate